

Wound Rotor Motors for the Auto-Shredder Industry

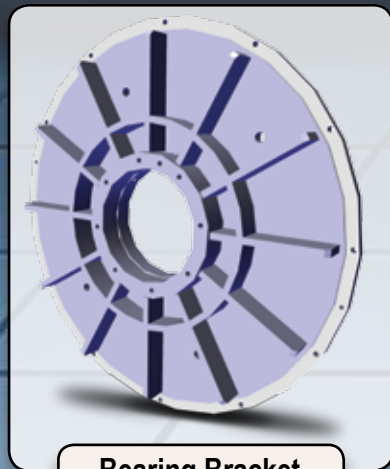

A Commitment to Reliability

TECO-Westinghouse Motor Company has been a trusted brand for over 100 years. Although our designs and processes have been refined over the years, we remain committed to producing rugged and reliable products for the most demanding needs. Our **Custom Engineered Shredder Duty Wound Rotor Motors**, are offered exclusively through Quad Plus, a leading provider of industrial control systems, solutions, and services for the auto-shredder industry.



Bearing Bracket

- Extra thickness
- Stiffening ribs

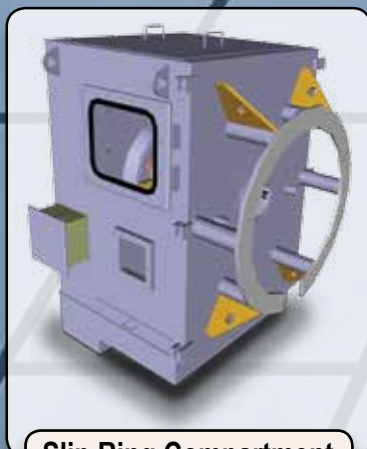

Slip Ring Compartment

- Inboard and outboard mounting capabilities

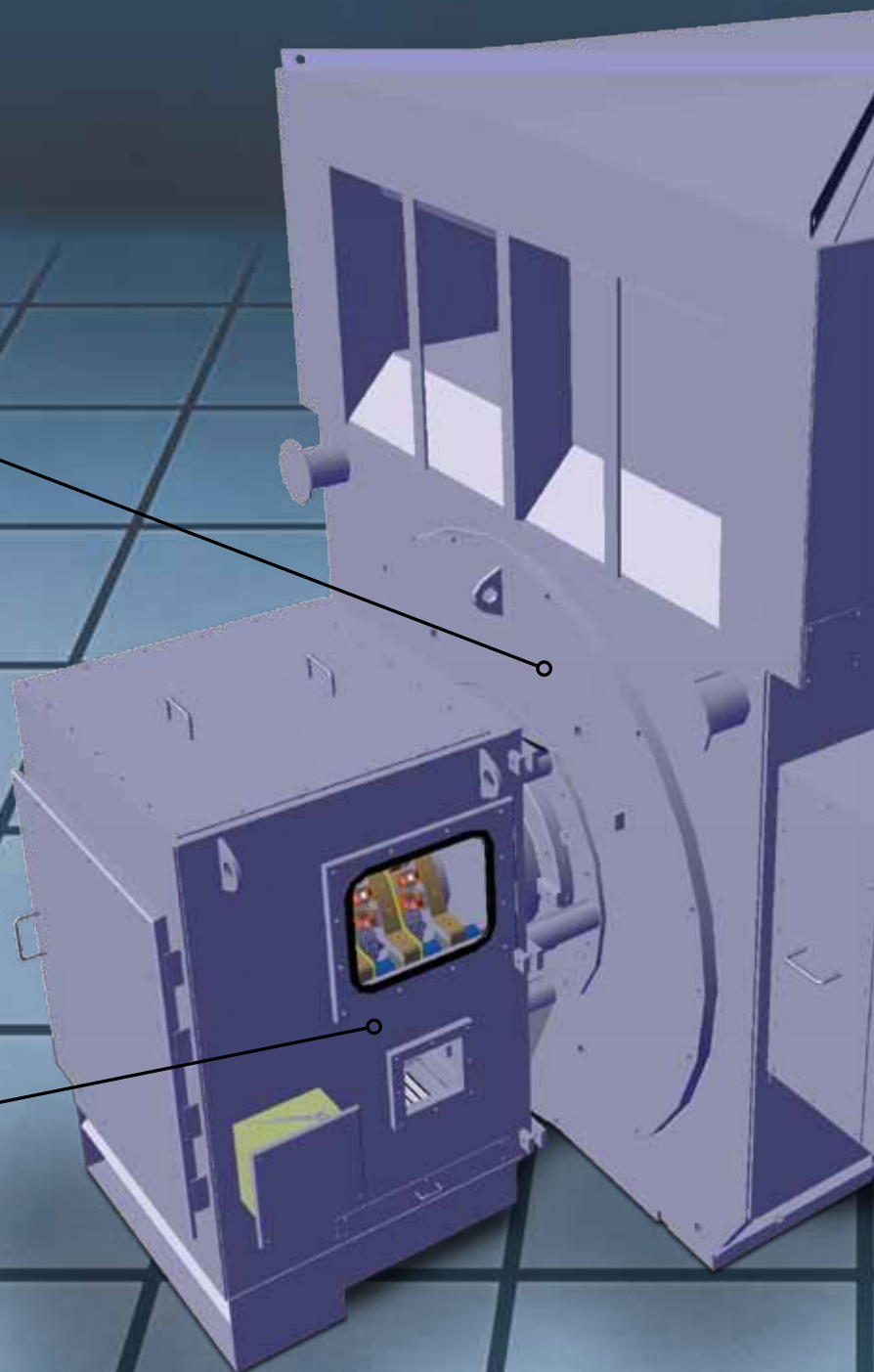

Shredder Duty Wound Rotor Motors Design Features & Capabilities

- 10,000 hp and larger
- Custom designed machines for drop-in replacements
- Electrical Design with High Breakdown Torque & Increased Air Gap
- Heavy Duty Bracing of Stator and Rotor Windings
- High Quality Slip Rings and Brushes
- Arc Flash Detection in Slip Ring Compartment

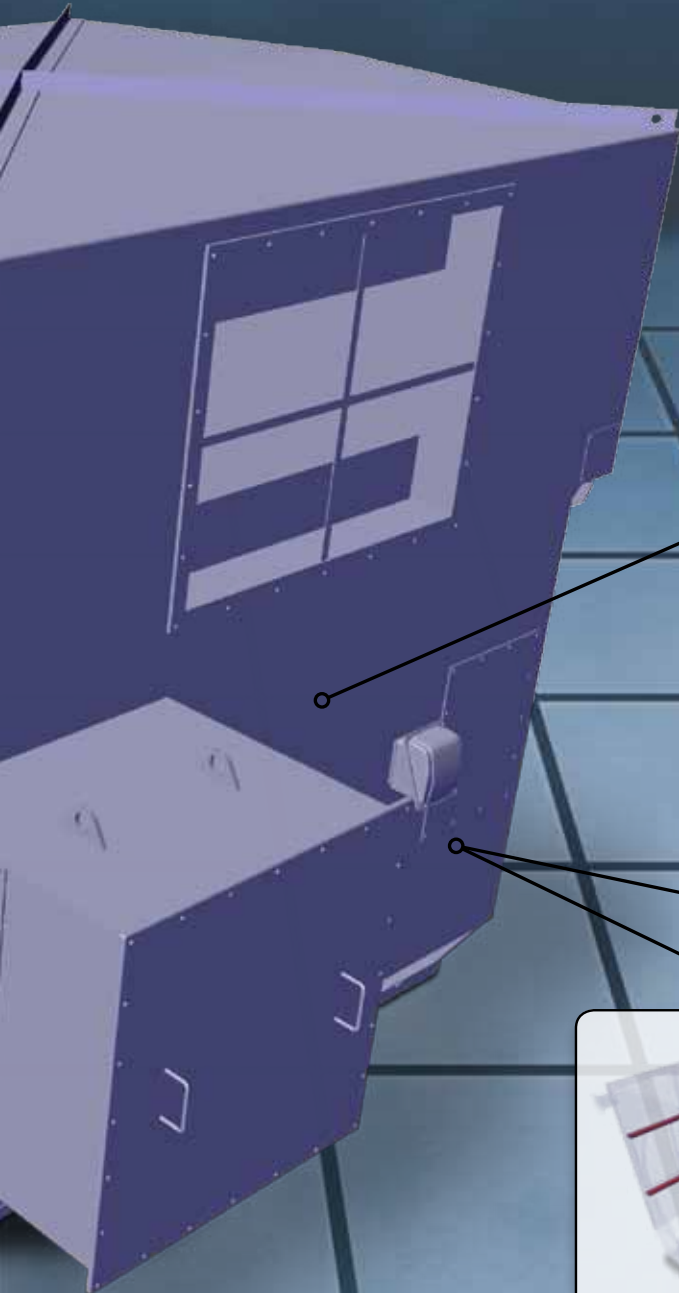

Rotor

- Robust design with extra spider arms
- Lateral bracing for increased torsional stiffness
- High strength shaft material



Frame

- Extra ribs for frame skin strength (left)
- Structural pipes between bulkheads for extra rigidity (right)

Motor Service Solutions

Complete Motor Solutions

TECO-Westinghouse has a complete product line of motors to provide any industry with custom motor solutions. In addition to our Shredder Duty Wound Rotor Motors, we offer custom engineered squirrel cage induction motors and a wide variety of stock motors available from 5 warehouses throughout the US.

Aftermarket Services

TECO-Westinghouse Motor Company's Service Division offers you the most complete large motor service package available. More than simple repairs of an electric motor, we deliver comprehensive solutions to complex problems. Our innovative engineering and design facilities, along with 110 years of practical experience in building large motors, will provide you with the most viable service alternative.

Whether you need repair assistance, engineering analysis, or renewal parts for your motor, TECO-Westinghouse Motor Company is the most qualified large motor service organization in the world.

Complete Line of Stock Motors

- 1/3 – 1750 HP in stock
- NEMA Design C / High Torque
- IEEE 841
- 115 – 4160 Volts

Induction Motors

- 250 – 30,000 HP
- 300 – 3600 RPM
- Copper/ Copper Alloy Rotor Construction

Synchronous Motors

- 1000—100,000 HP
- 180—1800 RPM
- Replacement Motors for Aging Designs

TECO   **Westinghouse**

5100 N. IH-35
Round Rock, Texas 78681
1-800-451-8798

www.tecowestinghouse.com



Quad Plus

(815) 724-2242

Exclusive partner for TWMC
wound rotor shredder motors

www.quadplusrecycling.com