

PA7300 INVERTER SERIES

Pump Quick Start Manual



TECO   **Westinghouse**

Rev. 1.0 / Nov 27th 2007

Quick Start Guide for Pump Applications

This guide is to simplify the start up of the PA7300 Inverter series for pump applications. It is not intended to replace the PA7300 Installation and Operation Manual 4H358D0250007, and the user is urged review this manual. There are three methods of control or combinations thereof that that may be selected; *Keypad*, *Analog Signal (external terminal)* or *Serial Communication*. Only Keypad and Analog Signal will be covered as Serial Communication is beyond the scope of this manual. For Serial Communication control or special external control, the user is referred to the PA7300 Installation and Operating Manual.

SAFETY FIRST!

Step 1 - Before Starting the Inverter

- Referring to the PA7300 Instruction Manual, please review and verify that the correct inverter size for the motor was received free of damage. To ensure personnel safety and to avoid equipment damage, follow the precautions and the installation procedures for mounting, wiring, and operating environment.

⚠ CAUTION - To avoid damage to the inverter when removing the inverter cover and/or LCD Operator, refer to Appendix B for the proper procedure.

- In accordance applicable codes make electrical connections to the motor and input power terminals. (Refer to the block diagram, Fig. 4). *No other external connections should be made at this time, as the initial control will be from the Keypad.*

Step 2 - Apply Power to the Drive

- Apply AC power to the Inverter and observe the LCD Display Line 1; it should read "Freq. Cmd 00.00Hz". Line 2 should read "TECO". The red LED on the **STOP** key should be ON. The **DRIVE** and **FWD** LED's should be ON. (See Fig. 1 below)

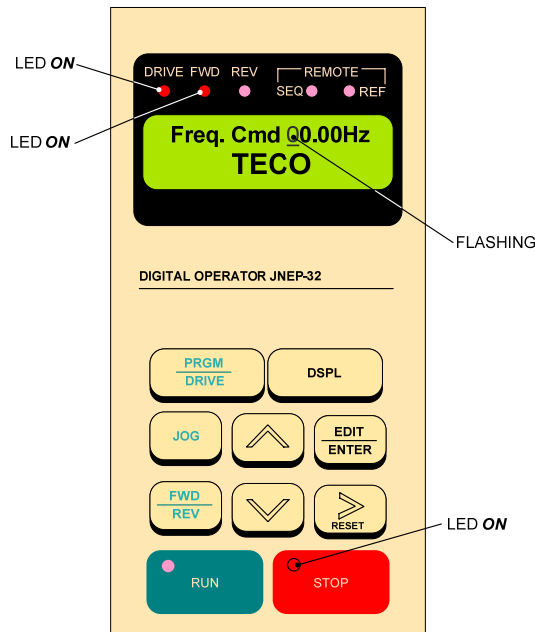



Fig. 1 PA7300 KEYPAD



Step 3 - Set Drive to Run Mode



- If the red **DRIVE** LED is not ON with AC power up, press the **PGRM / DRIVE** key until the red **Drive** LED is ON. The Inverter is now in the **RUN** mode.

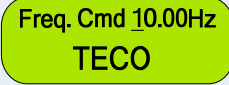

Step 4 - Check Pump Motor Operation



- Enter **10.00Hz** for the frequency reference and set parameter **Sn-05 = 0010** to disable Reverse Direction operation. **Note:** The output from the inverter is displayed in **Hz** as factory default. If desired, the output may be displayed in per cent (%) of full speed. (see appendix)

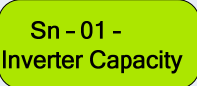

To set the output frequency to 10.00 Hz press the UP arrow key  Once ;

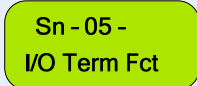
The display should read  Press the  Key to save.

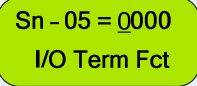
To set the parameter Sn-05 = 0010, press the  Key and then the  Key twice;

The display should read  Press the  Key until display shows 

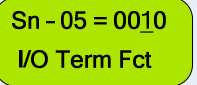
Press the  Key the display should read  Press the  Key to scroll to the third digit

Press the  Key once. The display should read  Press the  Key to save.

Press the  Key to return to the output frequency display as in Fig. 1.

- Press the **RUN** key, and check the pump direction of rotation. If the direction is not correct, press the **STOP** key and wait until the pump has come to a complete **STOP**. Next, **Power Down the inverter.**
-  **Danger**
After the power has been turned OFF, wait at least 5 minutes until the charge indicator extinguishes completely before touching any wiring, circuit boards or components.
- Reverse any **two** of the pump motor connections at the inverter (U(T1),V(T2), or W(T3)). Next, following **STEP 2**, Power-up the inverter; the motor direction should now be correct.

Step 5 – Select Method of Control



- Before selecting the method of control, ensure the inverter is in the **STOP** mode.
- There are two methods of control or combinations thereof that may be selected; **Keypad** and **Analog Signal**.



RUN / STOP Command - Can be provided from the keypad or from an external contact (see Fig. 2a).



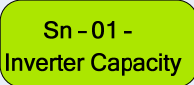

Speed Reference – Can be from the keypad or from an external analog signal (0 – 10 VDC or 4 – 20 mA). see Fig's 3a,3b, and 3c.

- The method of control is set by parameter **Sn – 04**. The table on the next page shows the value that **Sn – 04** needs to be set for the various combinations of control.

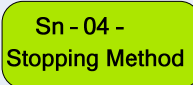
Parameter Sn – 04 =		
Function	Start / Stop	Speed Reference
0011	Keypad	Keypad
0001	External Contact	Keypad
0010	Keypad	External Analog
0000	External Contact	External Analog

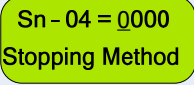
To set parameter Sn-04 press the  Key, and then the  Key twice;

The display should read  Press the  Key until the display shows 

Press the  Key; the display should read  To select the desired combination in accordance with the table value, press the  Key to scroll to the digit position and the  Key to select, the digit value (0 or 1). After the selection press the  Key to save.

Press the  to return to the output frequency display as in Fig. 1.

- After the method of control has been selected, if external control wiring is required, (e.g. external analog), **Power Down the inverter before removing any covers or making any connections.** In the following pages are wiring examples for Start / Stop, E-Stop, Restart, and Analog Connections.



Danger

After the power has been turned OFF, wait at least 5 minutes until the charge indicator extinguishes completely before touching any wiring, circuit boards, or components.

DIGITAL INPUT / OUTPUT terminal connections

Fig's 2a, 2b, and 2c below show the terminal connections for input control functions. The connections shown are typical and the user is referred to the **PA7300 Manual** if additional information is required. Fig. 2d shows an example for the use of the **Fault Output Relay**.

Fig. 2a Start / Stop switch connection

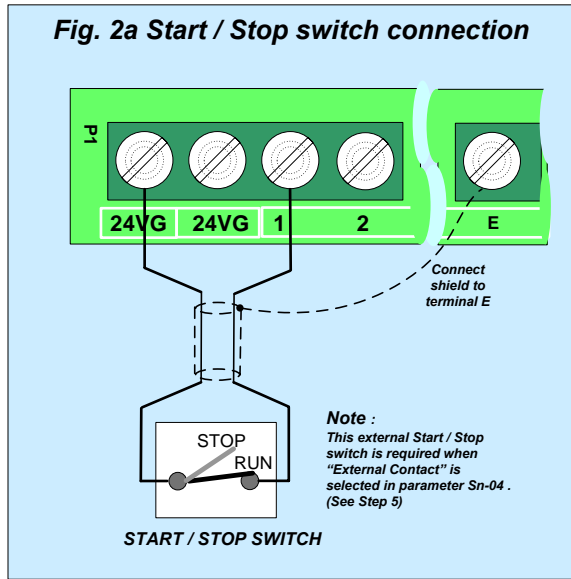

Fig. 2b External Fault contact connection

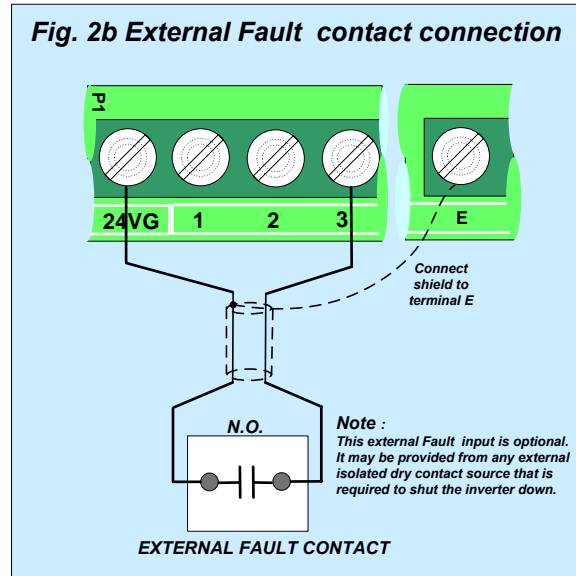

Fig. 2c Fault Reset switch connection

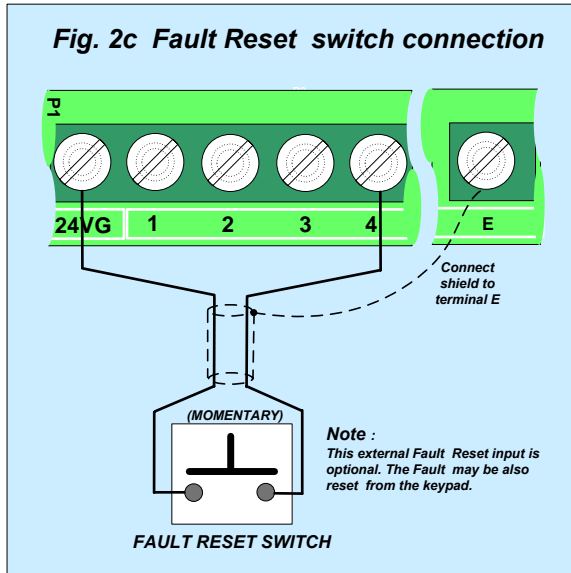
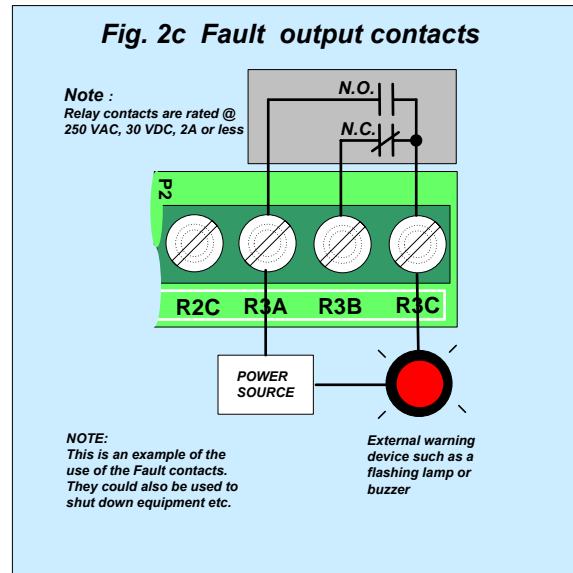

Fig. 2c Fault output contacts



ANALOG INPUT terminal connections

Fig's 3a,3b, and 3c.show the various analog input schemes that can be used to control the output frequency and thus the speed of the pump motor when **External Analog** is selected by **Sn-04** in **STEP 5**. Only one method may be used as the input source with Fig. 3a Potentiometer Input being most common.

Fig. 3a Speed Control Potentiometer Input

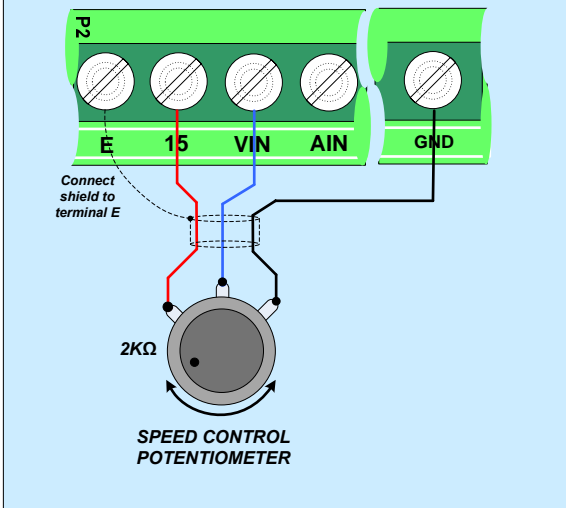

Fig. 3b 0 - +10 VDC Analog Input

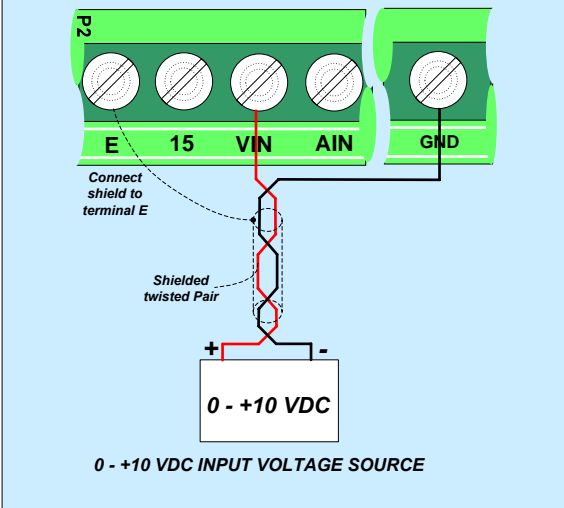
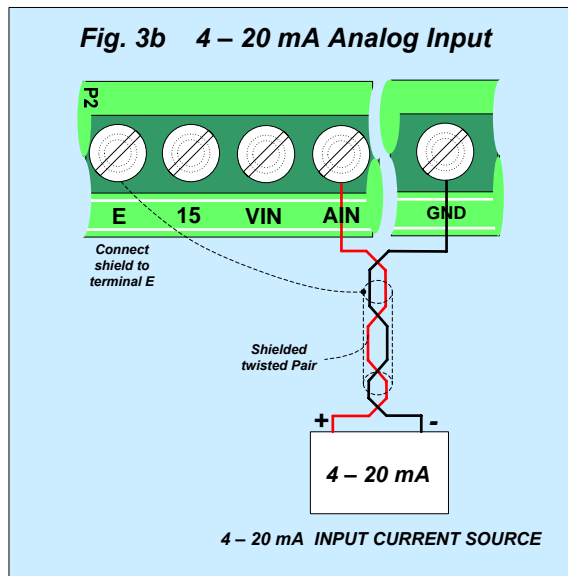

Fig. 3b 4 – 20 mA Analog Input



PA7300 BLOCK DIAGRAM

Fig. 4 is an overall basic electrical connection diagram for the **PA7300**. It is used in conjunction with the other sections of this guide to give the user the ability to successfully start up a Pump application. More detailed information is available in the **PA7300 Manual** to which the user is referred, if further information is required.

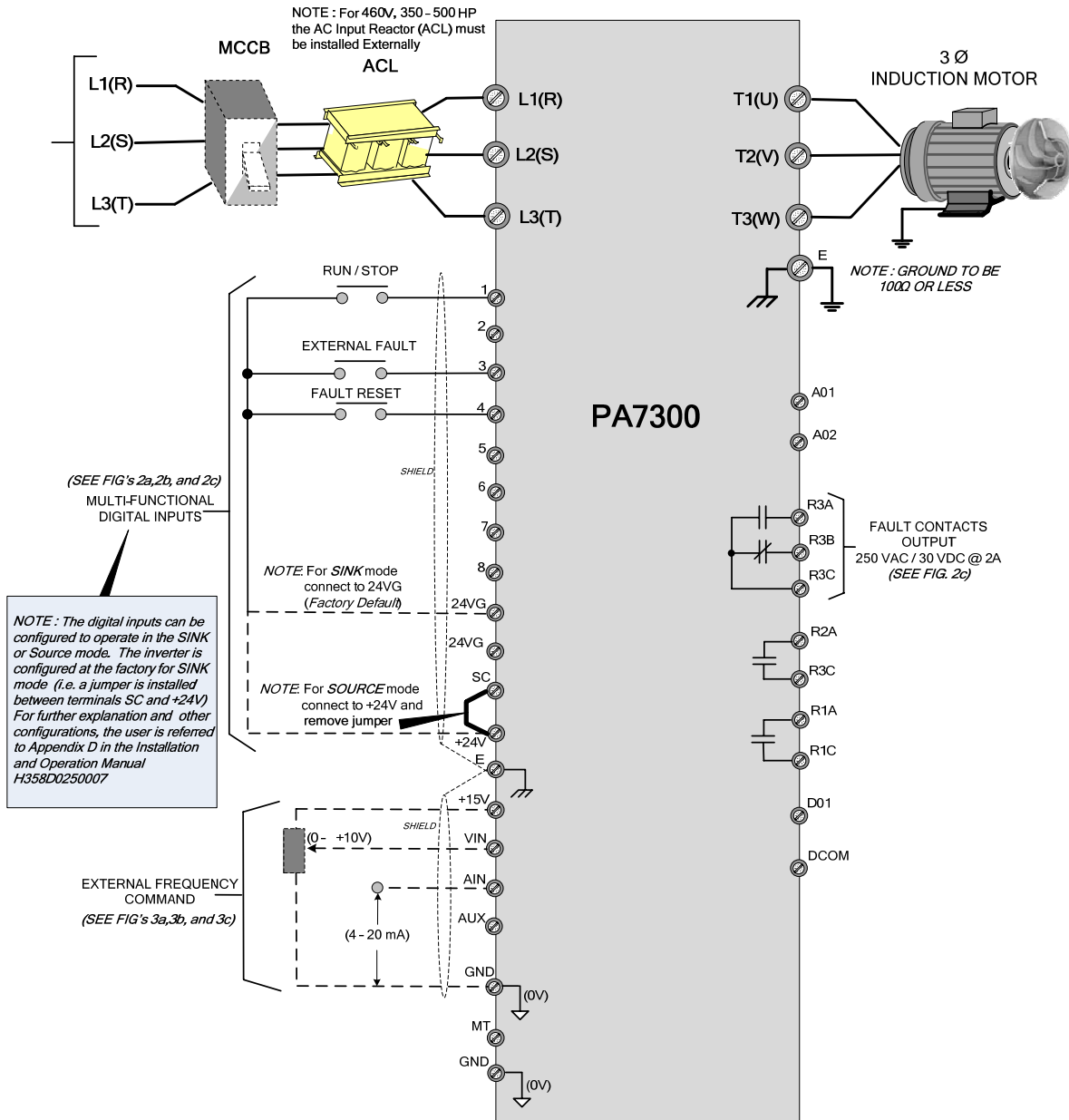



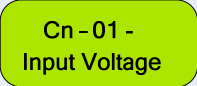

Fig. 4 PA7300 Pump APPLICATION DIAGRAM



Appendix A-

Changing display to read output speed in percent (%) of full speed.

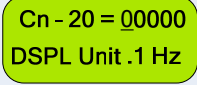

The display is factory defaulted to show the inverter output frequency in **Hz**. If desired, the display can be changed to show the output frequency as a **percentage** of full speed. To do this parameter **Cn-20** must be changed from (00000) to (00001) as follows:

To set parameter Cn-20 press the  Key, and then the  Key 4 times;

The display should read  Press the  Key until display shows 

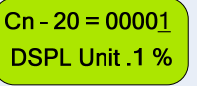
Press the  Key; the display should read  Press the  Key and scroll to the

last digit position and then press the  Key; The display should read 

Press the  Key to save. Press the  to return to the main display.

Appendix B -

Removing the LCD Digital Operator and Inverter Cover(s)

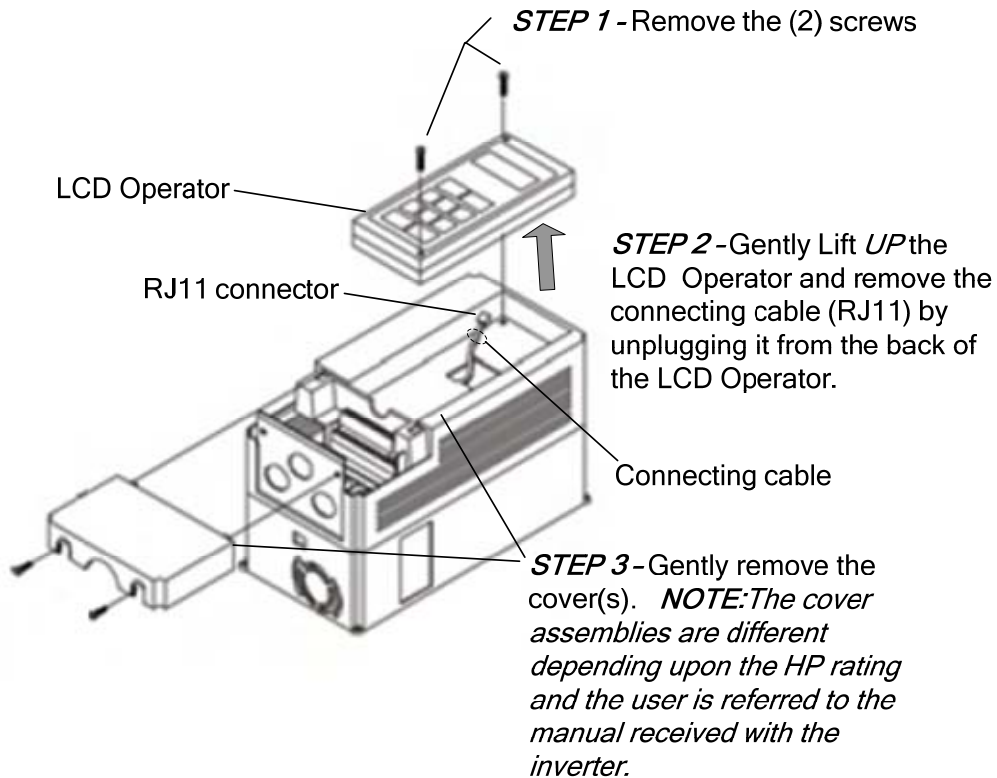



5100 N. IH-35
Round Rock, Texas 78681

1-800-279-4007

www.tecowestinghouse.com