

MAX-E2[®]/841



TECO   **Westinghouse**



NEMA
Premium



CC002A



ELECTRICAL DESIGN

- 1 - 500 HP; 2, 4, 6 pole
- 3600, 1800, 1200 RPM
- 3 Phase, 60 Hz, 460V
- Motors can be re-rated for 380, 400 and 415 VAC at 50 Hz.
- Designed to meet NEMA MG-1, MG-13, and IEEE 841
- Stock available in 460V; other voltages available, contact factory for details.
- Premium Efficiency; meets or exceeds the requirements of NEMA MG1-12.60, NEMA Premium Efficiency, table 12-12, and Canadian Federal Efficiency Levels defined in CSA C390-93. Full load efficiency of all ratings is certified under the EEV Program of the CSA.
- UL recognized, Class F, non-hygroscopic insulation system with Inverter duty magnet, index, heavy heat resistance enameled copper wire insures longer winding life and reliability.
- CSA certified for Class I, Division 2, Group B, C & D; Class II, Division 2, Group F & G. Non-sparking, non-static fan
- Class B temperature rise, 80°C rise by resistance method at 1.0 S.F.; 90°C rise at 1.15 S.F. Class F insulation with Phenolic Alkyd Resin Varnish – 2 dips and bakes
- Three leads, solderless lug terminals.
- Meets IEEE 45 Marine Duty and ABS Type Certified
- Meets GM 7E-TA specifications.
- Suitable for Inverter Duty applications - 20:1 constant torque and 60:1 variable torque applications. 350 HP and larger are 3:1 CT.

MECHANICAL DESIGN

- NEMA Design B torques as a minimum
- Bearing temperature rise is below 45°C for all 4P and 6P ratings; 50°C for all 20 motors.
- Sound pressure levels are below 85 dBA providing quiet operation.
- Full cast iron construction: frame, brackets, fan cover, and conduit box.
- Frame provided with two threaded drain holes c/w drain plugs; a drilled and tapped hole for a ground lug is provided on the frame.
- Corrosion-resistant cast iron conduit box with IP65/B66 rated protection has twice the volume required by NEMA. The conduit box is fully gasketed with NPT threaded conduit entry.
- Regreaseable bearing construction with inner bearing caps prevent bearing contamination.
- Non-sparking plastic or bronze fan.
- All interior exposed surfaces including stator coil ends and rotor surfaces are cleaned and coated with moisture resistant varnish. The exterior is painted with zinc-chromate epoxy base with a blue finish.
- Stainless steel hardware and nameplate.
- Vibration will not exceed 0.08 inches per second.
- Optimum rotor design allows for industry leading locked rotor torque per locked rotor amp levels
- Dual Drilled Feet - longer frames (i.e. 145T drilled also for 143T) through 449T Frames only

**5 Year Warranty
from the Date of
Manufacture!**

AEHH8B Vibration Level/ SMP (n=46)

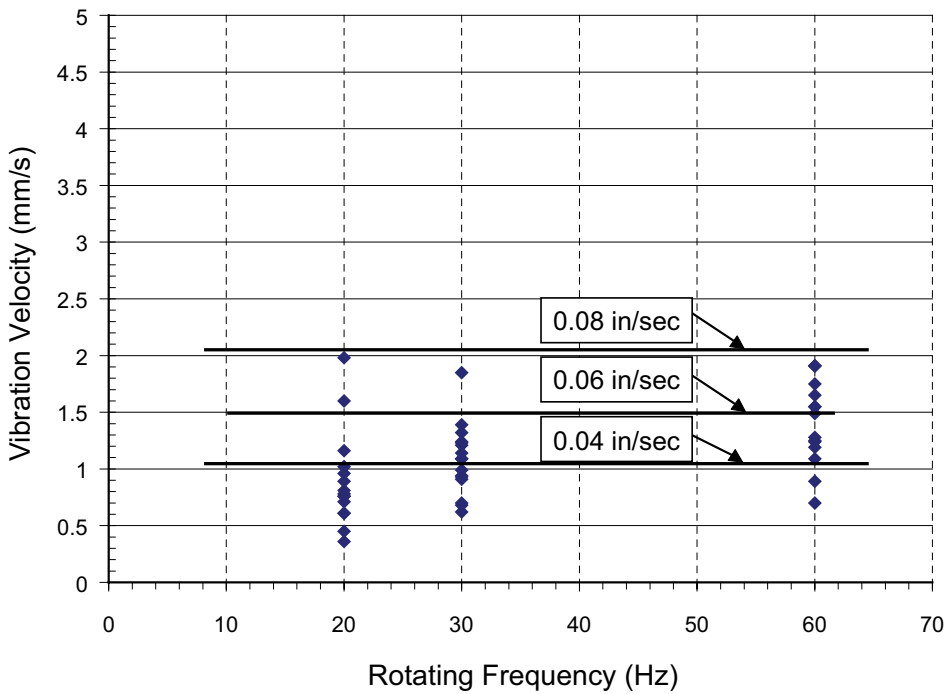

Non-Sparking,
Non-Static Producing Fan

Cast

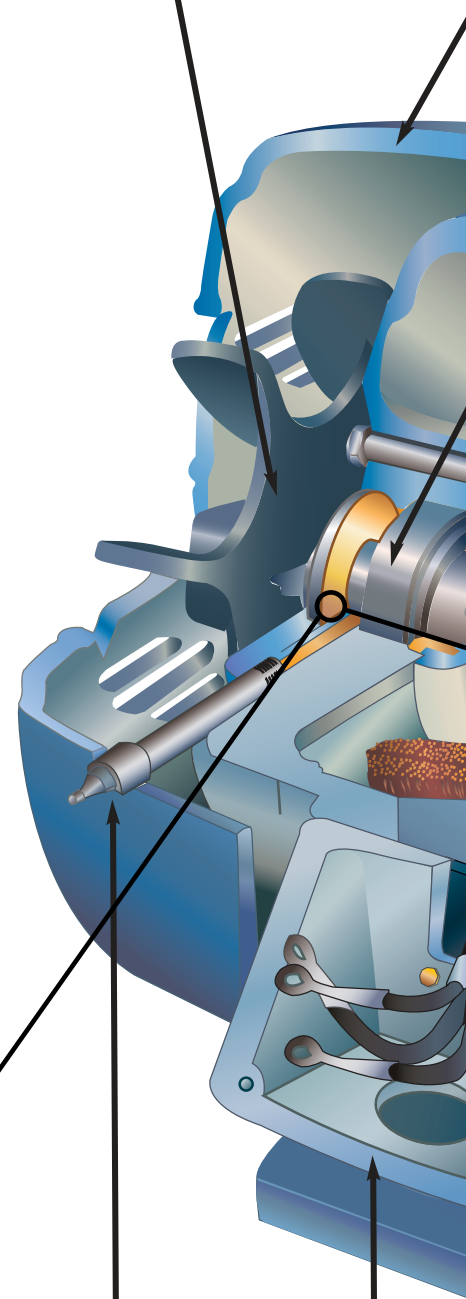

Grease Discharge Plug

Cast Iron Box

Inpro/Seal™

The Inpro/Seal™ "VBXX" bearing isolator, installed on the drive-end and non-drive end for all frames sizes (143T-449T), prevents bearing contamination from moisture, dust, dirt or other materials.

- Dynamically balanced rotor not to exceed 0.08 inches/ second peak velocity; and every motor is guaranteed to meet IEEE 841 vibration standards. A vibration test report is shipped with each motor.
- The foot flatness and shaft runout meet or exceed IEEE 841.
- All cast iron construction except fabricated conduit box for 447T/449T frames.

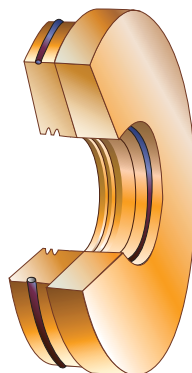

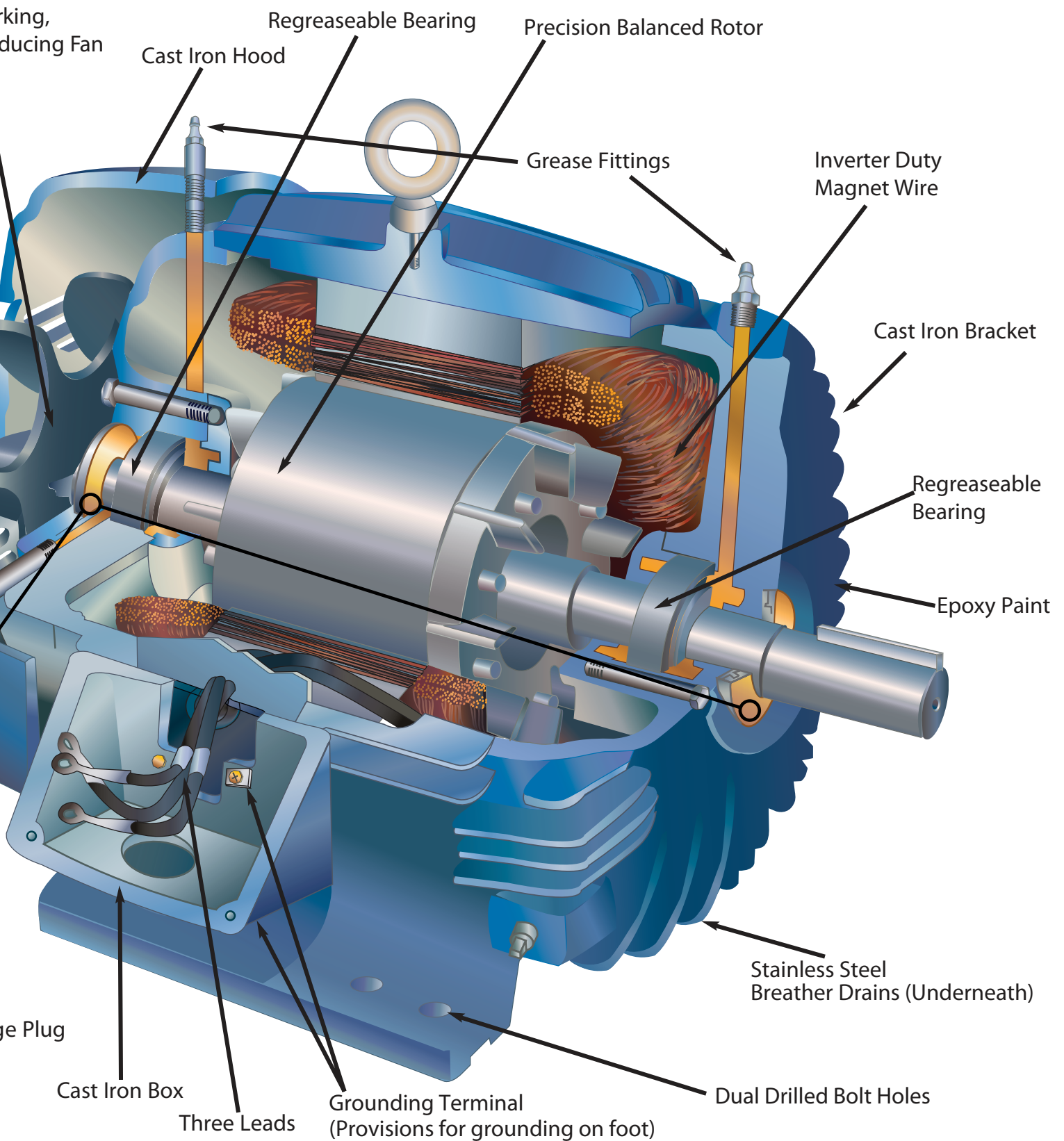

- UL recognized and CSA approved for inverter duty per NEMA MG 1, Part 31. 300 HP and below (Motor service factor is 1.0 when operated on a VFD).
- Inverter Duty Magnet Wire capable of withstanding voltage spikes of up to 2200V.
- Speed Ranges: 60:1 VT, 20:1 CT. 350 HP and larger are 3:1 CT.



TECO   **Westinghouse**

5100 N. IH-35
Round Rock, Texas 78681
1-800-279-4007

www.tecowestinghouse.com

SM-MXE2/841 3-16