

INVERTER

E510

START-UP AND INSTALLATION MANUAL



230V Class 1~

IP66/NEMA 4X

0.4 - 2.2 kW / 0.5 - 3 HP

230V Class 3~

IP66/NEMA 4X

0.4 - 15 kW / 0.75 - 20 HP

460V Class 3~

IP66/NEMA 4X

0.45- 18.5 kW / 1 - 25 HP

Read all operating instructions before installing, connecting (wiring), operating, servicing, or inspecting the inverter.

Ensure that this manual is made available to the end user of the inverter.

Store this manual in a safe, convenient location.

The manual is subject to change without prior notice.

Refer to the E510 Instruction Manual (www.tecowestinghouse.com).

**** STATEMENT ****

Si Desea descargar el manual en español diríjase a este Link: www.tecowestinghouse.com

Table of Contents

Preface	0-1
1 Safety Precautions	1-1
1.1 Before Supplying Power to the Inverter	1-1
1.2 Wiring	1-2
1.3 Before Operation	1-3
1.4 Parameters Setting	1-3
1.5 Operation	1-4
1.6 Maintenance, Inspection and Replacement	1-5
1.7 Disposal of the Inverter	1-5
1 Consignes de sécurité (Français)	1-6
1.1 Avant d'alimenter le disque dur	1-6
1.2 Câblage	1-6
1.3 Avant l'opération	1-7
1.4 Configuration Paramètre	1-7
1.5 Opération	1-8
1.6 Entretien, Inspection et remplacement	1-8
1.7 Mise au rebut du variateur	1-9
2 Model Description	2-1
2.1 Nameplate Data	2-1
2.2 Inverter Models – Motor Power Rating	2-2
3 Environment and Installation	3-1
3.1 Environment	3-1
3.2 Warning Labels	3-2
3.3 Removing the Front Cover and Keypad	3-3

3.4 Inverter Exterior.....	3-5
3.5 Wire Gauges, Tightening Torque and Short Circuit Rating	3-8
3.6 Wiring Peripheral Power Devices	3-9
3.7 General Wiring Diagram.....	3-11
3.8 User Terminals.....	3-12
3.9 Power Terminals	3-15
3.10 Inverter Wiring.....	3-17
3.11 Input Power and Motor Cable Length	3-19
3.12 Cable Length vs, Carrier Frequency	3-19
3.13 Installing an AC Line Reactor	3-19
3.14 Power Input Wire Size and NFB	3-20
3.15 Control Circuit Wiring	3-20
3.16 Inverter Specifications.....	3-21
3.17 General Specifications	3-24
3.18 Inverter De-rating Based on Carrier Frequency.....	3-26
3.19 Inverter Dimensions	3-27
4. Keypad and Programming Functions	4-1
4.1 LED Keypad	4-1
4.2 Parameters.....	4-8
4.3 Description of Parameters	4-27
5. Check Motor Rotation and Direction.....	5-1
6. Speed Reference Command Configuration.....	6-1
6.1 Reference from the Keypad	6-1
6.2 Reference from an Analog Signal (0-10V / 4-20mA) / Speed Pot	6-2
6.3 Reference from Serial Communication RS485.....	6-4
6.4 Reference from Pulse Input	6-6
6.5 Change Frequency Unit from Hz to rpm	6-7

7. Operation Method Configuration (Run / Stop)	7-1
7.1 Run / Stop from the Keypad.....	7-1
7.2 Run / Stop from External Switch / Contact or Pushbutton	7-2
7.3 Run / Stop from Serial Communication RS485	7-4
8. Motor and Application Specific Settings	8-1
8.1 Set Motor Nameplate Data	8-1
8.2 Acceleration and Deceleration Time	8-2
8.3 Volt/Hz Curve Modification (Torque Boost).....	8-3
8.4 Rapid Stop	8-4
8.5 Forward and Reverse Jog.....	8-5
8.6 Analog Output Setup.....	8-6
9. Using PID Control for Constant Flow / Pressure Applications	9-1
9.1 What is PID Control.....	9-1
9.2 Connect Transducer Feedback Signal	9-3
9.3 Engineering Units.....	9-4
9.4 Sleep / Wakeup Function	9-5
10 Troubleshooting, Fault Diagnostics and Maintenance	10-1
10.1 General	10-1
10.2 Fault Detection Function	10-1
10.3 General Troubleshooting	10-6
10.4 Routine and Periodic Inspection	10-7
10.5 Routine Maintenance	10-10
14. Commonly Used Parameters	11-1
00-02 Run command selection	11-1
00-05 Main Frequency Command Source Selection	11-3
00-14 Acceleration time 1	11-5

00-15 Deceleration time 1	11-5
01-00 V/f curve selection.....	11-6
03-00 ~ 03-05 Multi-function terminal function.....	11-9
03-11 ~ 03-12 Relay (R1A-R1C / R2A-R2C) output.....	11-18
03-13 Frequency detection level.....	11-20
03-14 Frequency detection width.....	11-20
04-11 Analog Voltage & Current Input Selections AI1/AI2	11-21
04-02 ~ 04-10 Analog Input Parameters.....	11-22
04-11 Analog Output A01 Function Selection.....	11-25
07-00 Momentary Power Loss and Restart	11-26
07-01 Auto Restart Delay Time.....	11-26
07-02 Number of Auto Restart Attempts.....	11-26
08-00 Trip Prevention Selection.....	11-27
08-01 ~ 08-05 Trip Prevention Parameters	11-27
12-00 Display Mode	11-28
12-01 ~ 12-05 Display Scaling and Custom Unit Parameters	11-28
13-02 Fault Log Display / Fault Log Clearance Function.....	11-30
13-08 Reset Drive to Factory Settings	11-30
Appendix A: UL Instructions.....	A1

1. Safety Precautions (English)

1.1 Before supplying Power to the Inverter



Warning

The main circuit must be correctly wired. For single phase supply use input terminals (R/L1, T/L3) and for three phase supply use input terminals (L1(L), L2, L3(N)). Terminals T1, T2, T3 must only be used to connect the motor. Connecting the input supply to any of the T1, T2 or T3 terminals will cause damage to the inverter.



Caution

- To avoid the front cover from disengaging or other physical damage, do not carry the inverter by its cover. Support the unit by its heat sink when transporting. Improper handling can damage the inverter or injure personnel, and should be avoided.
- To avoid the risk of fire, do not install the inverter on or near flammable objects. Install on nonflammable objects such as metal surfaces.
- If several inverters are placed inside the same control panel, provide adequate ventilation to maintain the temperature below 40°C/104°F (50°C/122°F without a dust cover) to avoid overheating or fire.
- When removing or installing the digital operator, turn off the power first, and then follow the instructions in this manual to avoid operator error or loss of display caused by faulty connections.



Warning

This product is sold subject to IEC 61800-3. In a domestic environment this product may cause radio interference in which case the user may need to apply corrective measures.

1.2 Wiring



Warning

- Always turn OFF the power supply before attempting inverter installation and wiring of the user terminals.
- Wiring must be performed by a qualified personnel / certified electrician.
- Make sure the inverter is properly grounded. (230V Class: Grounding impedance shall be less than 100Ω. 460V Class: Grounding impedance shall be less than 10Ω.)
- Please check and test emergency stop circuits after wiring. (Installer is responsible for the correct wiring.)
- Never touch any of the input or output power lines directly or allow any input or output power lines to come in contact with the inverter case.
- Do not perform a dielectric voltage withstand test (megger) on the inverter this will result in inverter damage to the semiconductor components.



Caution

- The line voltage applied must comply with the inverter's specified input voltage. (See product nameplate section 2.1)
- Use wire gauge recommendations and torque specifications. (See Wire Gauge and Torque Specification section 3.7)
- Never connect input power to the inverter output terminals T1, T2, T3.
- Do not connect a contactor or switch in series with the inverter and the motor.
- Do not connect a power factor correction capacitor or surge suppressor to the inverter output.
- Ensure the interference generated by the inverter and motor does not affect peripheral devices.

1.3 Before Operation



Warning

- Make sure the inverter capacity matches the parameters 13-00.
- Reduce the carrier frequency (parameter 11-01) if the cable from the inverter to the motor is greater than 80 ft (25m). A high-frequency current can be generated by stray capacitance between the cables and result in an overcurrent trip of the inverter, an increase in leakage current, or an inaccurate current readout.
- Be sure to install all covers before turning on power. Do not remove any of the covers while power to the inverter is on, otherwise electric shock may occur.
- Do not operate switches with wet hands, otherwise electric shock may result.
- Do not touch inverter terminals when energized even if inverter has stopped, otherwise electric shock may result.

1.4 Parameter Setting



Caution

- Do not connect a load to the motor while performing a rotational auto-tune.
- Make sure the motor can freely run and there is sufficient space around the motor when performing a rotational auto-tune.

1.5 Operation



Warning

- Be sure to install all covers before turning on power. Do not remove any of the covers while power to the inverter is on, otherwise electric shock may occur.
- Do not connect or disconnect the motor during operation. This will cause the inverter to trip and may cause damage to the inverter.
- Operations may start suddenly if an alarm or fault is reset with a run command active. Confirm that no run command is active upon resetting the alarm or fault, otherwise accidents may occur.
- Do not operate switches with wet hands, otherwise electric shock may result.
- It provides an independent external hardware emergency switch, which emergently shuts down the inverter output in the case of danger.
- If automatic restart after power recovery (parameter 07-00) is enabled, the inverter will start automatically after power is restored.
- Make sure it is safe to operate the inverter and motor before performing a rotational auto-tune.
- Do not touch inverter terminals when energized even if inverter has stopped, otherwise electric shock may result.
- Do not check signals on circuit boards while the inverter is running.
- After the power is turned off, the cooling fan may continue to run for some time.



Caution

- Do not touch heat-generating components such as heat sinks and braking resistors.
- Carefully check the performance of motor or machine before operating at high speed, otherwise Injury may result.
- Note the parameter settings related to the braking unit when applicable.
- Do not use the inverter braking function for mechanical holding, otherwise injury may result.
- Do not check signals on circuit boards while the inverter is running.

1.6 Maintenance, Inspection and Replacement



Warning

- Wait a minimum of five minutes after power has been turned OFF before starting an inspection. Also confirm that the charge light is OFF and that the DC bus voltage has dropped below 25Vdc.
- Never touch high voltage terminals in the inverter.
- Make sure power to the inverter is disconnected before disassembling the inverter.
- Only authorized personnel should perform maintenance, inspection, and replacement operations. (Take off metal jewelry such as watches and rings and use insulated tools.)



Caution

- The Inverter can be used in an environment with a temperature range from 14° -104°F (-10-40°C) and relative humidity of 95% non-condensing.
- The inverter must be operated in a dust, gas, mist and moisture free environment.

1.7 Disposal of the Inverter



Caution

- Please dispose of this unit with care as an industrial waste and according to your required local regulations.
- The capacitors of inverter main circuit and printed circuit board are considered as hazardous waste and must not be burned.
- The Plastic enclosure and parts of the inverter such as the top cover board will release harmful gases if burned.

1. Consignes de sécurité (Français)

1.1 Avant d'alimenter le disque dur



Avertissement

- Le circuit principal doit être correctement câblée. Pour les terminaux monophasés d'approvisionnement de l'utilisation des intrants (R/L1, T/L3) et de trois bornes d'entrée de l'utilisation de l'offre de phase (R/L1, S/L2, T/L3). U/T1, V/T2, W/T3 ne doivent être utilisés pour connecter le moteur. Raccordement de l'alimentation d'entrée à l'un des U/T1, V/T2 W/T3 ou bornes risque d'endommager le lecteur.



Attention

- Pour éviter que le couvercle ne se désengage ou de tout autre dommage physique, ne portez pas le lecteur par son couverture. Soutenir le groupe par son dissipateur de chaleur lors du transport. Une mauvaise manipulation peut endommager le lecteur ou blesser le personnel, et doit être évitée.
- Pour éviter que les risques d'incendie, ne pas installer le lecteur sur ou à proximité d'objets inflammables. Installer sur des objets ininflammables comme les surfaces métalliques.
- Si plusieurs disques sont placés dans le même panneau de contrôle, fournir une ventilation adéquate pour maintenir la température en dessous de 40 ° C/104 ° F (50 ° C/122 ° F sans housse de protection) pour éviter la surchauffe ou incendie.
- Lors d'un retrait ou d'installation de l'opérateur numérique, éteignez-le d'abord, puis de suivre les instructions de ce manuel pour éviter les erreurs de l'opérateur ou de la perte de l'affichage causé par des connexions défectueuses.



Avertissement

- Lors d'un retrait ou d'installation de l'opérateur numérique, éteignez-le d'abord, puis de suivre les instructions de ce manuel pour éviter les erreurs de l'opérateur ou de la perte de l'affichage causé par des connexions défectueuses....

1.2 Câblage



Avertissement

- Coupez toujours l'alimentation électrique avant de procéder à l'installation d'entraînement et le câblage des terminaux utilisateurs.
- Le câblage doit être effectué par un personnel qualifié / électricien certifié.
- Assurez-vous que le lecteur est correctement mis à la terre. (220V Classe: impédance de mise à la terre doit être inférieure à 100Ω Classe 440V: Impédance de mise à la terre doit être inférieure à 10Ω.)
- vérifier et tester mes circuits d'arrêt d'urgence après le câblage. (L'Installateur est responsable du câblage.)
- Ne touchez jamais de l'entrée ou de lignes électriques de sortie permettant directement ou toute entrée ou de lignes de puissance de sortie à venir en contact avec le boîtier d'entraînement.
- Ne pas effectuer un test de tenue en tension diélectrique (mégohmmètre) sur le disque dur ou cela va entraîner des dommages de lecture pour les composants semi-conducteurs.



Attention

- La tension d'alimentation appliquée doit se conformer à la tension d'entrée spécifiée par le lecteur. (Voir la section signalétique du produit)
- Raccorder la résistance de freinage et de l'unité de freinage sur les bornes assignées.
- Ne pas brancher une résistance de freinage directement sur les bornes CC P (+) et N (-), sinon risque d'incendie.
- Utilisez des recommandations de la jauge de fil et les spécifications de couple. (Voir Wire Gauge et la section de spécification de couple) °
- Ne jamais brancher l'alimentation d'entrée aux bornes onduleur de sortie U/T1, V/T2, W/T3.
- Ne pas brancher un contacteur ou interrupteur en série avec le variateur et le moteur.
- Ne branchez pas un facteur condensateur de correction de puissance ou supprimeur de tension à la sortie du variateur °
- S'assurer que l'interférence générée par l'entraînement et le moteur n'a pas d'incidence sur les périphériques.

1.3 Avant l'opération



Avertissement

- Assurez-vous que la capacité du disque correspond aux paramètres de notation avant d'alimenter.
- Réduire le paramètre de la fréquence porteuse si le câble du variateur au moteur est supérieure à 80 pi (25 m). Un courant de haute fréquence peut être générée par la capacité parasite entre les câbles et entraîner un déclenchement de surintensité du variateur, une augmentation du courant ou d'une lecture actuelle inexactes.
- Veillez à installer tous les couvercles avant de l'allumer. Ne retirez pas les capots pendant que l'alimentation du lecteur est allumé, un choc électrique peut se produire autrement.
- Ne pas actionner d'interrupteurs avec les mains mouillées, un choc électrique pourrait survenir autrement.
- Ne touchez pas les bornes d'entraînement lorsqu'il est alimenté, même si le lecteur est arrêté, un choc électrique pourrait survenir autrement.

1.4 Configuration Paramètre



Attention

- Ne branchez pas une charge pour le moteur tout en effectuant un auto-tune.
- Assurez-vous que le moteur peut fonctionner librement et il y a suffisamment d'espace autour du moteur lors de l'exécution d'un auto-tune rotation.

1.5 Opération



Avertissement

- Veillez à installer tous les couvercles avant de l'allumer. Ne retirez pas les capots pendant que l'alimentation du lecteur est allumé, un choc électrique peut se produire autrement.
- Ne pas brancher ou débrancher le moteur pendant le fonctionnement. Le variateur pourrait se déclencher et ainsi endommager le lecteur.
- Les opérations peuvent commencer soudainement si une alarme ou un défaut est réarmé avec un ordre de marche active. Assurez-vous qu'un ordre de marche est actif lors de la réinitialisation de l'alarme ou de défaut, autrement des accidents peuvent se produire.
- Ne pas actionner d'interrupteurs avec les mains mouillées, un choc électrique pourrait survenir.
- Un interrupteur d'urgence externe indépendant est fourni, qui s'arrête en urgence vers le bas la sortie de l'onduleur en cas de danger.
- Si le redémarrage automatique après une récupération d'énergie est activée, le variateur démarrera automatiquement après le rétablissement du courant.
- Assurez-vous qu'il est sûr de faire fonctionner le variateur et le moteur avant d'effectuer un auto-tune rotation.
- Ne touchez pas les bornes d'entraînement lorsqu'il est alimenté même si l'onduleur s'est arrêté, un choc électrique pourrait survenir .
- Ne pas contrôler les signaux sur les circuits pendant que le lecteur est en marche.
- Après la mise hors tension, le ventilateur de refroidissement peut continuer à fonctionner pendant un certain temps.



Attention

- Ne touchez pas les composants générant de la chaleur tels que radiateurs et des résistances de freinage. 
- Vérifiez soigneusement la performance du moteur ou de la machine avant d'utiliser à grande vitesse, sous peine de blessure.
- Notez les réglages des paramètres liés à l'unité de freinage lorsque applicable.
- Ne pas utiliser la fonction de freinage d'entraînement pour un maintien mécanique, sous peine de blessure.
- Ne pas contrôler les signaux sur les circuits pendant que le lecteur est en marche.

1.6 Entretien, Inspection et remplacement



Avertissement

- Attendre un minimum de 5 minutes après que l'alimentation a été débranchée avant de commencer une inspection. Vérifiez également que le voyant de charge est éteint et que la tension du bus cc a chuté au-dessous de 25Vdc.
- Ne jamais toucher les bornes à haute tension dans le lecteur.
- Assurez-vous que l'alimentation du lecteur est débranché avant de démonter le lecteur.
- Seul le personnel autorisé peuvent faire l'entretien, l'inspection et les opérations de remplacement. (Enlevez les bijoux en métal tels que les montres et les bagues et utiliser des outils isolés.)

 **Attention**

- Le variateur peut être utilisé dans un environnement avec une gamme de température allant de 14 ° -104 ° F (10-40 ° C) et l'humidité relative de 95% sans condensation.
- Le variateur doit être utilisé dans un environnement sans poussière, gaz, vapeur et humidité.

1.7 Mise au rebut du variateur

 **Attention**

- jeter cet appareil avec soin comme un déchet industriel et selon les réglementations locales nécessaires.
- Les condensateurs du circuit principal d'entraînement et circuits imprimés sont considérés comme des déchets dangereux et ne doivent pas être brûlés.
- The Plastic enclosure and parts of the drive such as the top cover board will release harmful gases if burned.

2. Model Description

2.1 Nameplate Data

It is essential to verify the E510 inverter nameplate and make sure that the E510 inverter has the correct rating so it can be used in your application with the proper sized AC motor.

Unpack the E510 inverter and check the following:

- (1) The E510 inverter and start-up and installation manual (this document) are contained in the package.
- (2) The E510 inverter has not been damaged during transportation there should be no dents or parts missing.
- (3) The E510 inverter is the type you ordered. You can check the type and specifications on the main nameplate.
- (4) Check that the input voltage range meets the input power requirements.
- (5) Ensure that the motor HP matches the motor rating of the inverter.

(1HP = 0.746 kW)

PRODUCT: E510-401-H3N4	MOTOR RATING: 1HP/0.75kW		C	← Product Name and Motor Rating
INPUT : AC 3PH 50/60Hz	380-480V (+10%,-15%)	4.2A		
OUTPUT : AC 3PH 0-650Hz	0-480V	2.3A	IP66	← Output Power Specifications
MODEL : E510-401-H3N4				← Series No
P/N BARCODE	S/N BARCODE		CE	← UL and CE Marks
TECO Electric & Machinery Co., Ltd.			UL LISTED 196J IND. CONT. EQ. E177007	

Model Identification

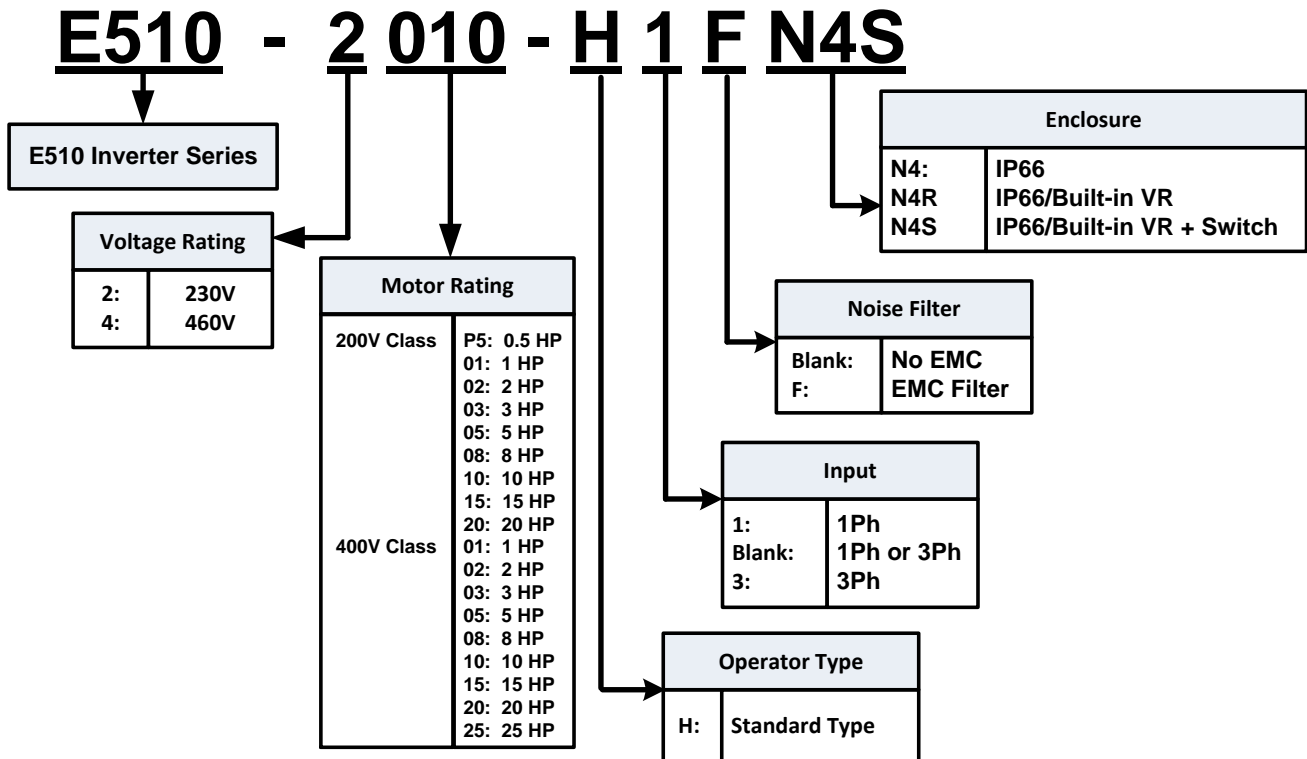

2.2 Inverter Models – Motor Power

IP66 / NEMA 4X Type

Model	Supply voltage (Vac)	HP	(kW)	Filter		VR		Switch		Frame Size
				V	X	V	X	V	X	
E510-2P5-H1FN4S	1 Phase 200~240V +10%-15% 50/60Hz	0.5	0.4	⊙		⊙		⊙		1
E510-201-H1FN4S		1	0.75	⊙		⊙		⊙		1
E510-202-H1FN4S		2	1.5	⊙		⊙		⊙		2
E510-203-H1FN4S		3	2.2	⊙		⊙		⊙		2
E510-2P5-HN4R	1 & 3 Phase 200~240V +10%-15% 50/60Hz	0.5	0.4		⊙	⊙			⊙	1
E510-201-HN4R		1	0.75		⊙	⊙			⊙	1
E510-202-HN4R		2	1.5		⊙	⊙			⊙	2
E510-203-HN4R		3	2.2		⊙	⊙			⊙	2
E510-205-H3N4	3 Phase 200~240V +10%-15% 50/60Hz	5	3.7		⊙		⊙		⊙	2
E510-208-H3N4		7.5	5.5		⊙		⊙		⊙	3
E510-210-H3N4		10	7.5		⊙		⊙		⊙	3
E510-215-H3N4		15	11		⊙		⊙		⊙	3
E510-220-H3N4		20	15		⊙		⊙		⊙	3
E510-401-H3FN4S	3 Phase 380~480V +10%-15% 50/60Hz	1	0.75	⊙		⊙		⊙		1
E510-401-H3N4		1	0.75		⊙		⊙		⊙	1
E510-402-H3FN4S		2	1.5	⊙		⊙		⊙		1
E510-402-H3N4		2	1.5		⊙		⊙		⊙	1
E510-403-H3FN4S		3	2.2	⊙		⊙		⊙		2
E510-403-H3N4		3	2.2		⊙		⊙		⊙	2
E510-405-H3FN4S		5	3.7	⊙		⊙		⊙		2
E510-405-H3N4		5	3.7		⊙		⊙		⊙	2
E510-408-H3FN4S		7.5	5.5	⊙		⊙		⊙		3
E510-408-H3N4		7.5	5.5		⊙		⊙		⊙	3
E510-410-H3FN4S		10	7.5	⊙		⊙		⊙		3
E510-410-H3N4		10	7.5		⊙		⊙		⊙	3
E510-415-H3FN4S		15	11	⊙		⊙		⊙		3
E510-415-H3N4		15	11		⊙		⊙		⊙	3
E510-420-H3N4		20	15		⊙		⊙		⊙	3
E510-425-H3N4		25	18.5		⊙		⊙		⊙	3

V: Built-in

X: None

3. Environment and Installation

3.1 Environment

The environment will directly affect the proper operation and the life span of the inverter. To ensure that the inverter will give maximum service life, please comply with the following environmental conditions:

Protection	
Protection Class	IP66 / NEMA 4X (Depending on models)
Operating Temperature	IP66 / NEMA 4X type: -10°C - +50°C (14-122 °F) If several inverters are placed in the same control panel, provide a heat removal means to maintain ambient temperatures below 40°C
Storage Temperature	-20°C - +60°C (-4 -140 °F)
Humidity:	95% non-condensing Relative humidity 5% to 95%, free of moisture. (Follow IEC60068-2-78 standard)
Altitude:	< 1000m (3,281 ft.)
Installation Site:	Avoid exposure to rain or moisture.
	Avoid direct sunlight.
	Avoid oil mist and salinity.
	Avoid corrosive liquid and gas.
	Avoid dust, lint fibers, and small metal filings.
	Keep away from radioactive and flammable materials.
	Avoid electromagnetic interference (soldering machines, power machines).
	Avoid vibration (stamping, punching machines etc.). Add a vibration-proof pad if the situation cannot be avoided.
Shock	Maximum acceleration: 1G (9.8m/s ²), for <20Hz
	Maximum acceleration: 0.6G (5.88m/s ²), for 20 - 50Hz (IEC60068-2-6 standard)

3.2 Warning Labels

Important: Warning information located on the front cover must be read upon installation of the inverter.

xPH-xxxV-xkW

 **DANGER / DANGER**
Cut-off the power and wait for 5 minutes before inspecting components.
Couper l'alimentation et attendre 5 minutes avant d'inspecter composants.

 **CAUTION / ATTENTION**
See manual before operation.
Consultez le manuel avant l'opération.

 **WARNING / AVERTISSEMENT**
Hot surface risk of burn
Risque de brûlure de surface chaude

3.3 Removing the Front Cover and Keypad



- Before making any wiring connections to the inverter the front cover needs to be removed.

IP66 / NEMA 4X

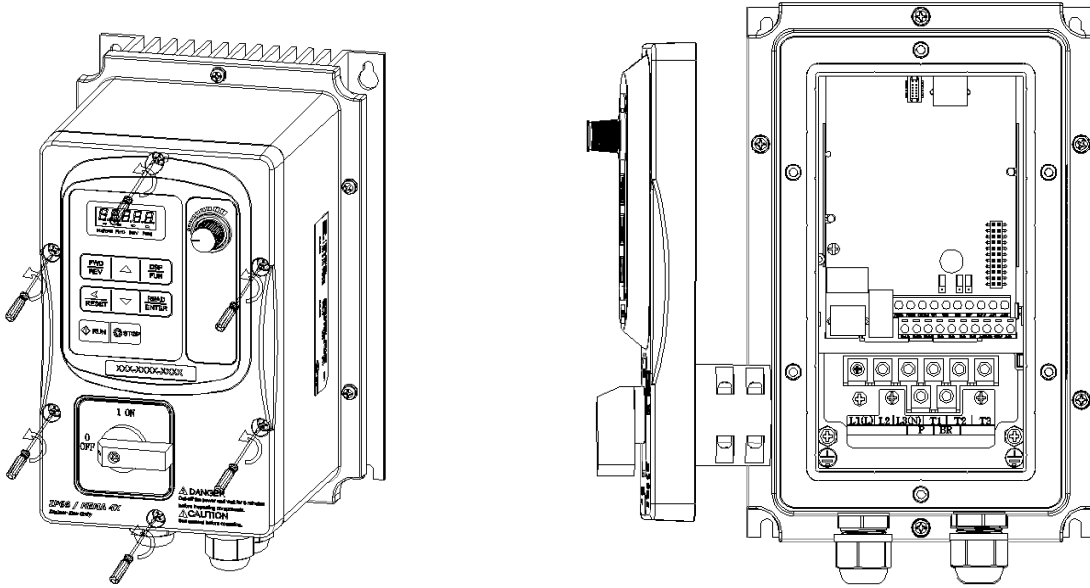

Step 1: Unscrew cover and place cover next to the inverter

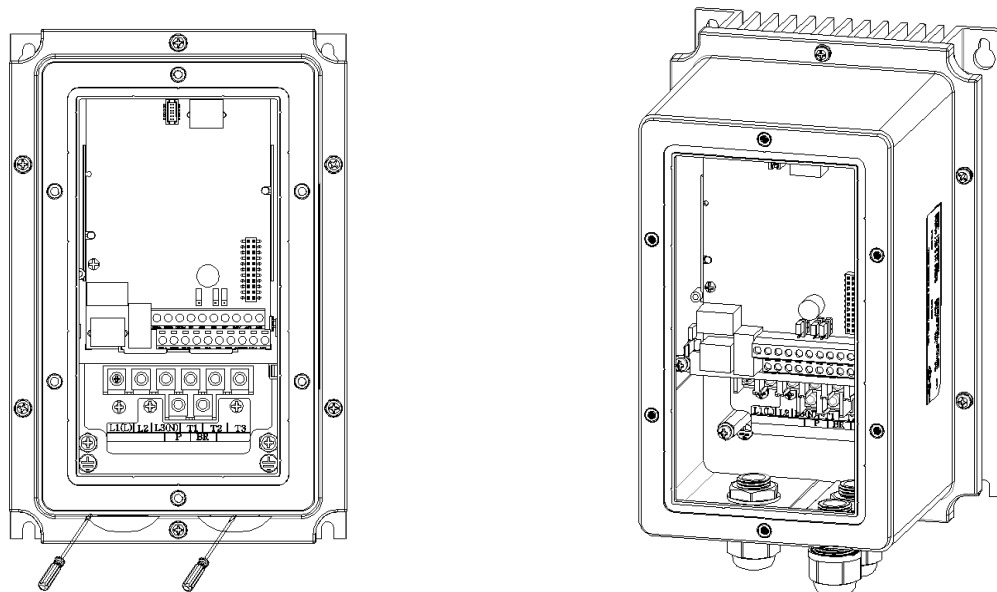

Step 2: Remove the rubber plugs and use the waterproof cable glands provided to connect cables.

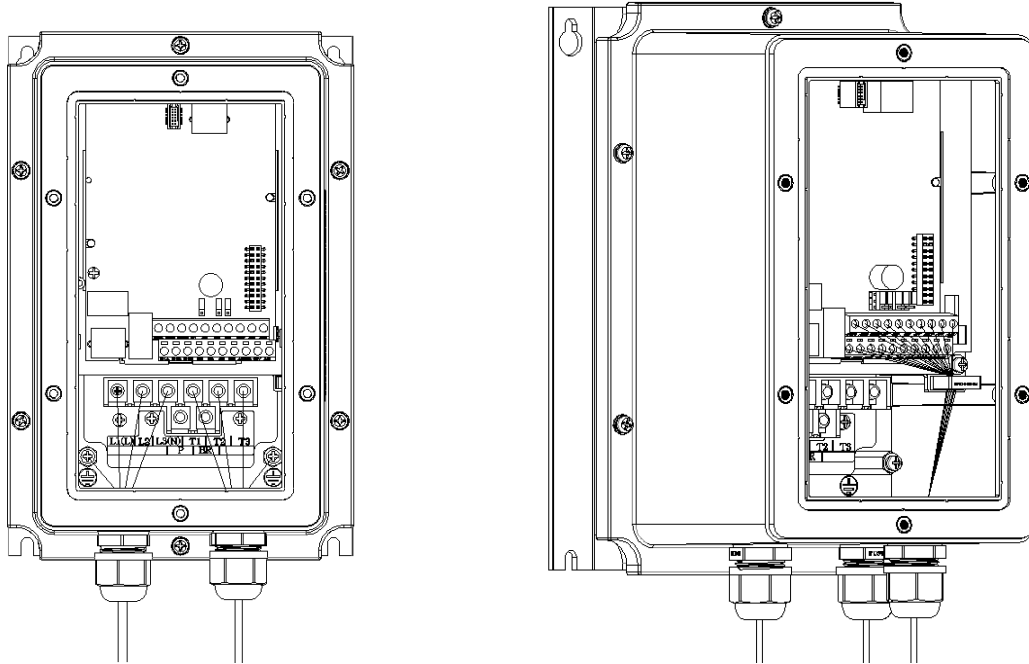

Step 3: Connect power & motor cables through the cable glands to the correct terminals

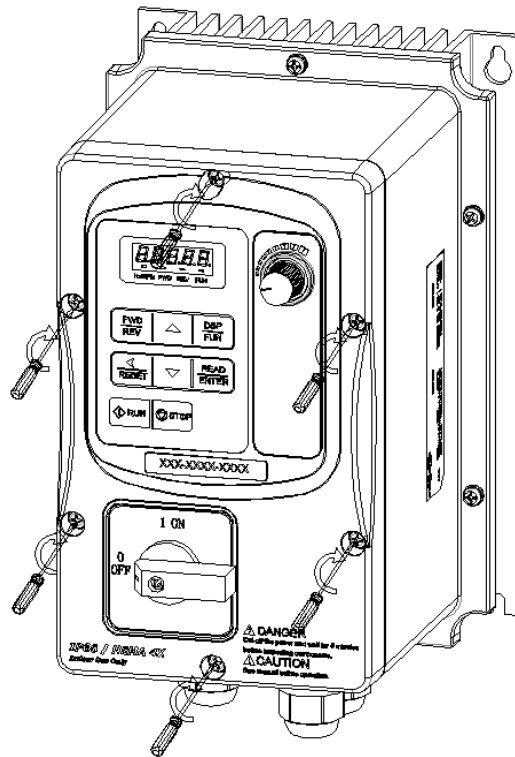

Step 4: Connect power & motor cables through the cable glands to the correct terminals

3.4 Inverter Exterior

IP66/NEMA4X

- (a) Single/Three phase: 230V 0.5~1HP
- Single phase: 230V 0.5~1HP
- Three phase: 230V 2HP; 460V 1~2HP

E510-Frame 1 (IP66/NEMA 4X With/Without VR and disconnect switches depending on the model)

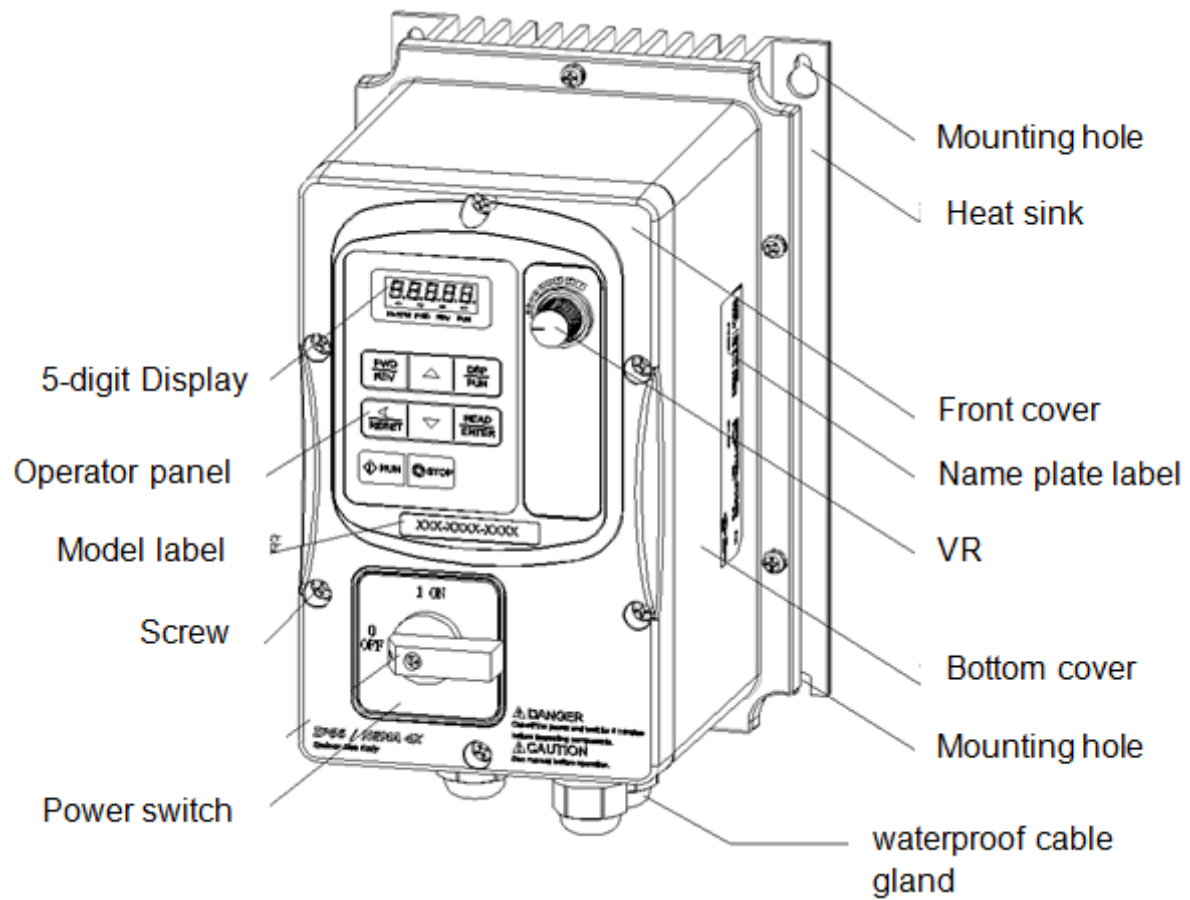

- (b) Single/Three phase: 230V 2~3HP
- Single phase: 230V 2~3HP
- Three phase: 230V 5HP; 460V 3~5HP

E510-Frame 2 (IP66/NEMA 4X With/Without VR and disconnect switches depending on the model)

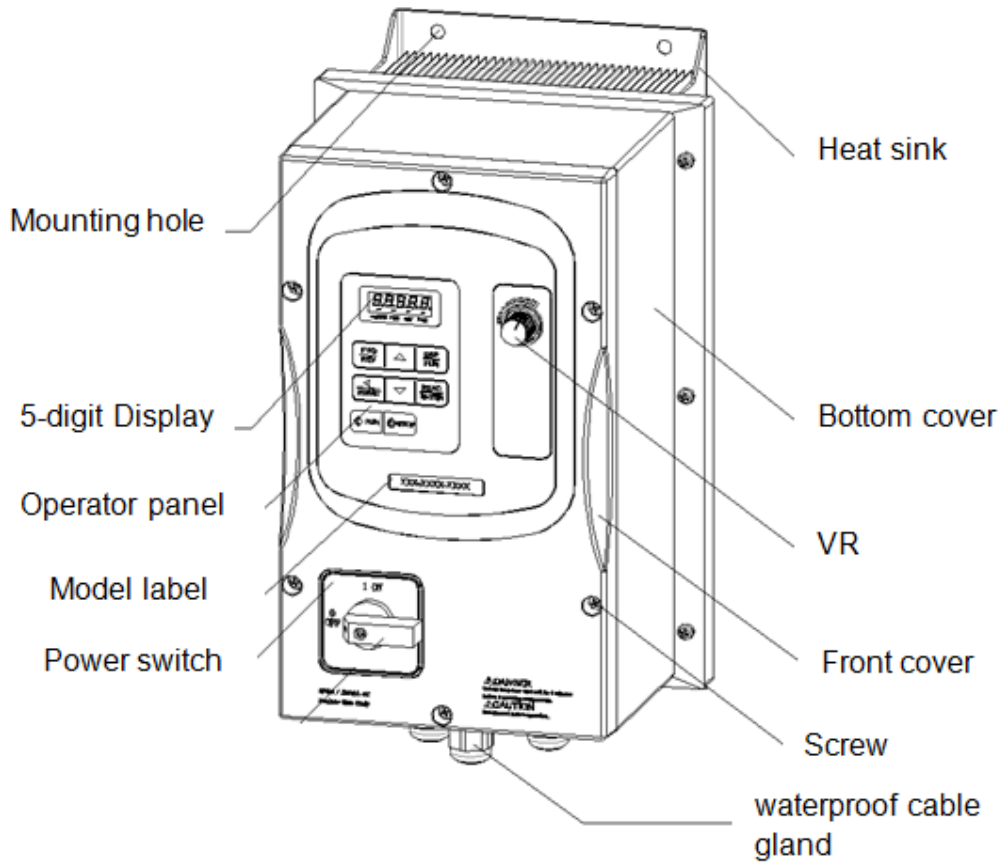

(c) Three phase: 230V 7.5~20HP; 460V 7.5~25HP

E510-Frame 3 (IP66/NEMA 4X With/Without VR and disconnect switches depending on the model)

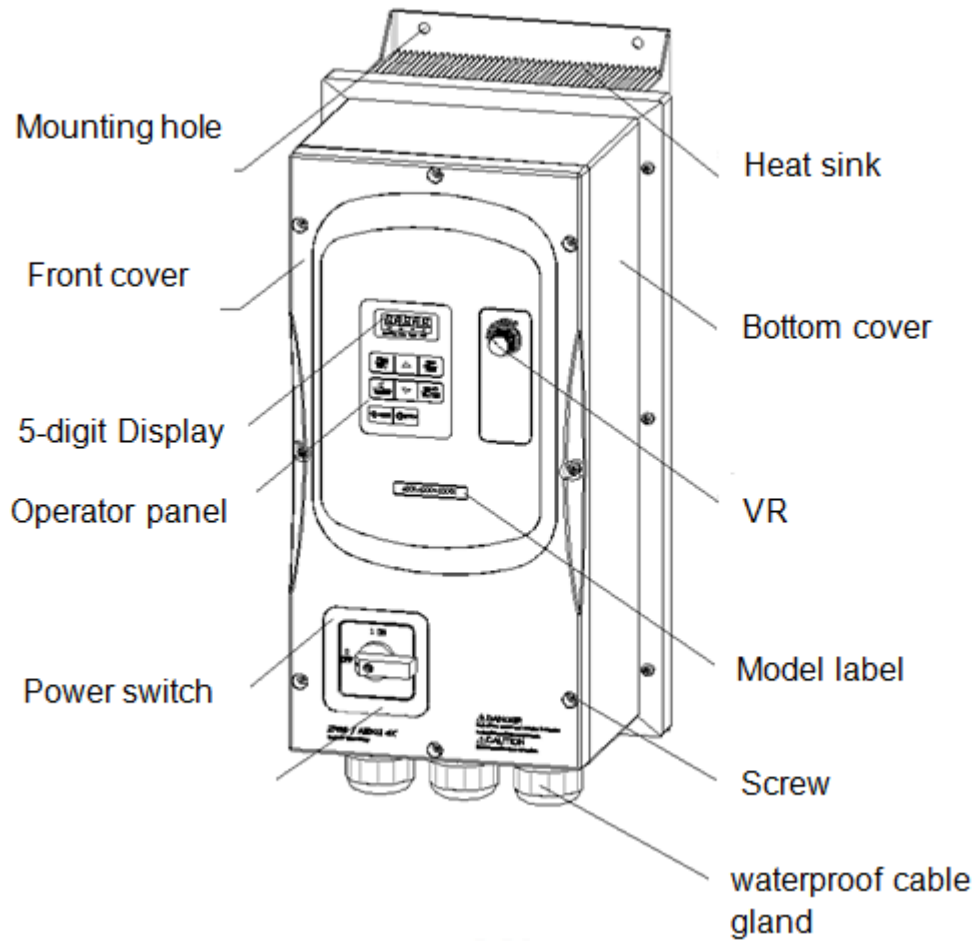

3.5 Wire Gauges, Tightening Torque, Terminal and Short Circuit Ratings.

To comply with UL standards, use UL approved copper wires (rated 75° C) and round crimp terminals (UL Listed products) as shown in table below when connecting to the main circuit terminals.

Model	TM1					TM2				
	Cable Size		Tightening torque			Cable Size		Tightening torque		
	AWG	mm ²	kgf.cm	lbf.in	Nm	AWG	mm ²	kgf.cm	lbf.in	Nm
Frame1	20~12	0.52~3.33	10.20	0.006	1.0	26~14	0.13~2.08	8.16	0.005	0.8
Frame2	18~8	0.81~8.37	18.35	0.010	1.8					
Frame3	14~6	2.08~13.30	24.47	0.014	2.4					
Frame4	4~3	21.15~26.67								

Terminals Electrical Rating

Model	Horsepower	Power Specification	Voltage (Volt)	Current(A)
Frame1	0.5/1	200V~240V	600	20
	1/2	380V~480V		
Frame2	2/3/5	200V~240V	600	45
	3/5	380V~480V		
Frame 3/4	7.5/10/15/20	200V~240V	600	65
	7.5/10/15/20/25	380V~480V	600	100

Short circuit rating

Device Rating		Short circuit Rating(A)	Maximum Voltage (Volt)
voltage	HP		
230V	0.5~20	5,000	240
460V	1~25	5,000	480

3.6 Wiring Peripheral Power Devices



Caution

- After power is shut off to the inverter the capacitors will slowly discharge. Do NOT touch and of the inverter circuitry or replace any components until the “CHARGE” indicator is off.
- Do NOT wire or connect/disconnect internal connectors of the inverter when the inverter is powered up or when powered off and the “CHARGE” indicator is on.
- Do NOT connect inverter output U, V and W to the supply power. This will result in damage to the inverter.
- The inverter must be properly grounded. Use terminal E to connect earth ground and comply with local standards.
- Do NOT perform a dielectric voltage withstand test (Megger) on the inverter this will result in inverter damage to the semiconductor components.
- Do NOT touch any of the components on the inverter control board to prevent damage to the inverter by static electricity.



Caution

- Refer to the recommended wire size table for the appropriate wire to use. The voltage between the power supply and the input of the inverter may not exceed 2%.

$$\text{Phase-to-phase voltage drop (V)} = \sqrt{3} \times \text{resistance of wire } (\Omega/\text{km}) \times \text{length of line (m)} \times \text{current} \times 10^{-3}.$$

(km=3280 x feet) / (m=3.28 x feet)

- Reduce the carrier frequency (parameter 11-01) If the cable from the inverter to the motor is greater than 25m (82ft). A high-frequency current can be generated by stray capacitance between the cables and result in an overcurrent trip of the inverter, an increase in leakage current, or an inaccurate current readout.
- To protect peripheral equipment, install fast acting fuses on the input side of the inverter. Refer to section 11.6 for additional information.

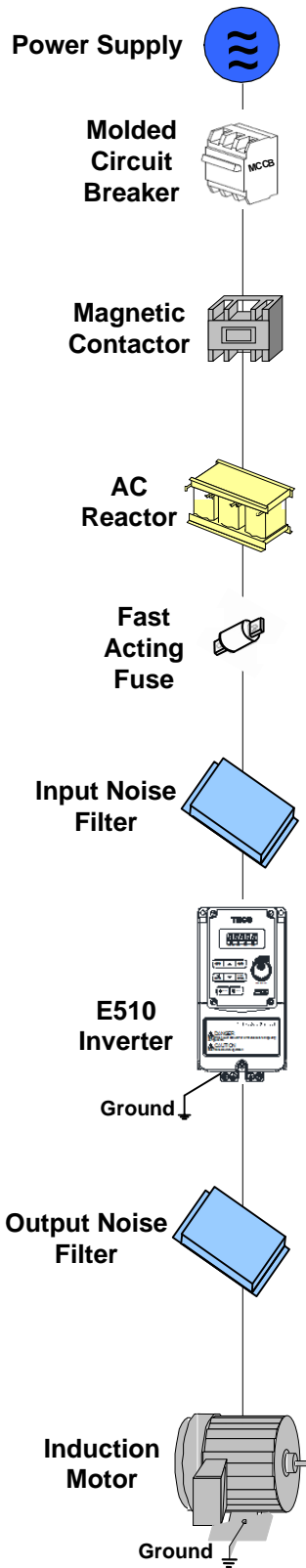

Power supply:

-  Make sure the correct voltage is applied to avoid damaging the inverter.

Molded-case circuit breaker (MCCB) or fused disconnect:

- A molded-case circuit breaker or fused disconnect must be installed between the AC source and the inverter that conforms to the rated voltage and current of the inverter to control the power and protect the inverter.

-  Do not use the circuit breaker as the run/stop switch for the inverter.

Ground fault detector / breaker:

-  Install a ground fault breaker to prevent problems caused by current leakage and to protect personnel. Select current range up to 200mA, and action time up to 0.1 second to prevent high frequency failure.

Magnetic contactor:

- Normal operations do not need a magnetic contactor. When performing functions such as external control and auto restart after power failure, or when using a brake controller, install a magnetic contactor.
-  Do not use the magnetic contactor as the run/stop switch for the inverter.

AC line reactor for power quality:

- When inverters are supplied by a high capacity power source (> 600KVA), an AC reactor can be connected to improve the power factor.



Install Fast Acting Fuse:

- To protect peripheral equipment, install fast acting fuses in accordance with the specifications in section 11 for peripheral devices.

Input Noise filter:

- A filter must be installed when there are inductive loads affecting the inverter. The inverter meets EN55011 Class A, category C3 when the TECO special filter is used.

Inverter:

- Output terminals T1, T2, and T3 are connected to U, V, and W terminals of the motor. If the motor runs in reverse while the inverter is set to run forward, swap any two terminals connections for T1, T2, and T3.
-  To avoid damaging the inverter, do not connect the output terminals T1, T2, and T3 to AC input power.
-  Connect the ground terminal properly. (230V series: Rg <100Ω; 460V series: Rg <10Ω.)

Output Noise filter:

- An output noise filter may reduce system interference and induced noise. See section 11 for peripheral devices.

Motor:

- If the inverter drives multiple motors the output rated current of the inverter must be greater than the total current of all the motors.

3.7 General Wiring Diagram

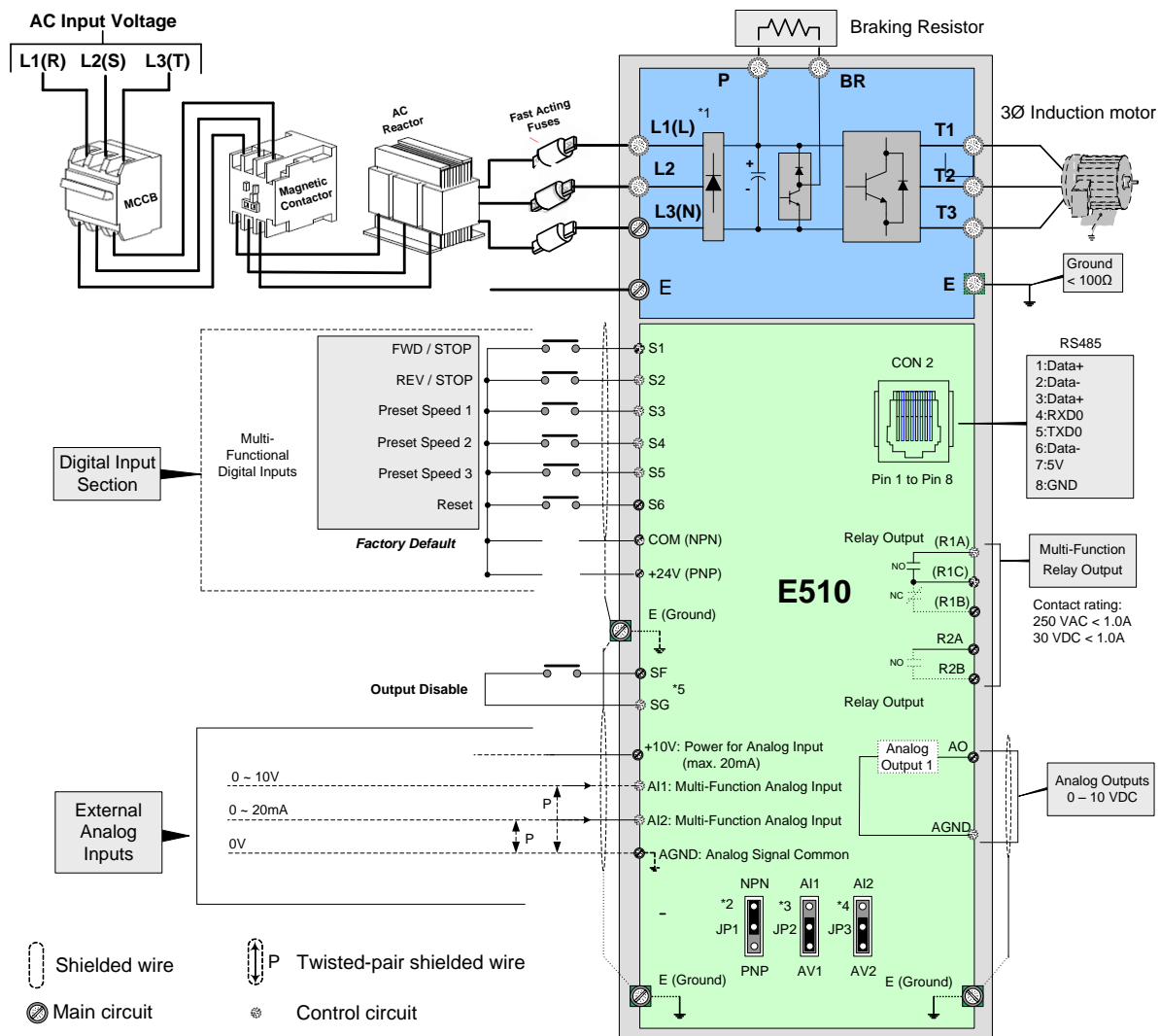

Notes:

*1: Use L1 (L) and L3 (N) for single phase input

*2: Use jumper JP1 to select between Sink (NPN, with 24VG common) or Source (PNP, with +24V common) for multi-function digital input terminals S1~S6.

*3: Use jumper JP2 to switch between voltage and current input for Multi-function analog input 1 (AI1).



*4: Use jumper JP3 to switch between voltage and current input for Multi-function analog input 1 (AI2).

*5: Run Permissive input SF and SG is a normally open input. This input should be open to enable the inverter output. To activate this input place a jumper wire between SF and SG.

3.8 User Terminals (Control Circuit Terminals)

R2A	R2B	COM	S1	S3	S5	SF	24V	A1	A12	
R1A	R1B	R1C	S2	S4	S6	SG	AGND	10V	AO	

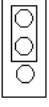
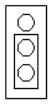
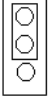
Jumper function descriptions

Jumper	Symbol	Function	Signal Reference	Note
JP1	 1 2 3	NPN/PNP selectable	NPN Input	Factory default setting
	 1 2 3		PNP Input	
JP2/JP3	 1 2 3	External signal type selection	0~20mA / 4~20mA Analog signal	Set parameters 00-05/00-06 to 2 or 3 (external analog input) to become effective
	 1 2 3		0~10VDC / 2~10VDC Analog signal	

Description of User Terminals

Type	Terminal	Terminal function	Signal level
Digital input signal	S1	Forward- Stop (Preset), Multi-function input terminal	24 VDC, 8 mA, Optical coupling isolation (Max, voltage 30 VDC, Input impedance 3.3kΩ)
	S2	Reverse - Stop (Preset), Multi-function input terminal	
	S3	Preset Speed0(5-02),Multi-function input terminal	
	S4	Preset Speed1(5-03), Multi-function input terminal	
	S5	Preset Speed2(5-05), Multi-function input terminal	
	S6	Fault reset input, Multi-function input terminal	
Relay output	R1A	NO(Normally open)	250VAC/1A(30VDC/1A)
	R1B	NC(Normally closed)	
	R1C	COMMON	
	R2A	Multi-function output: Run, Fault, setting Frequency ,Frequency Reached, Auto Restart, Momentary AC Power Loss, Rapid Stop ,Base Block Stop Mode, Motor Overload Protection, Drive Overload Protection, Over-torque Threshold Level、Preset Current level Reached、Preset Brake Frequency Reached, PID Feedback Signal Loss, Final count value reached, Initial count value reached, PLC Status Indicator ,PLC control...	
	R2B		
24VPower supply	COM	Digital signal common terminal (JP1 Switching NPN position)	±15%,Max output current 60mA
	24V	Digital signal common terminal (JP1 Switching PNP position)	
The analog input signal	10V	Built in Power for an external speed potentiometer	10V(Max current:20mA)
	AI1	Multifunctional analog input: JP2 selects voltage or current input Voltage: JP2 in AV1 position Current: JP2 in AI1 position	0 ~ 10V,(Max current:20mA) (Input impedance: 153KΩ)
	AI2	Multifunctional analog input: JP3 selects voltage or current input Voltage: JP3 in AV2 position Current: JP3 in AI2 position	0 ~ 10V,0 ~20mA (Input impedance: 153KΩ)
	AGND	The analog common terminal	----
		Shielding wire connecting terminal (The earth)	----
The analog output signal	AO	Multifunctional analog output terminal*3	0 ~10V,(Max current:2mA)
	AGND	The analog common terminal	----
Safety switch	SF	Terminal SF is a safety input and can be used to disable drive externally	
	SG		

Notes:

*1:Multi-function digital input can be referred to in this manual.

- Group 03: External Terminals Digital Input / Output Function Group.

*2:Multi-function analog input can be referred to in this manual..

- Group 04 - External Terminal Analog Signal Input (Output) Function Group.

*3:Multi-function analog output can be referred to in this manual.

- Group 04 - External Terminal Analog Signal Input (Output) Function Group.



Caution

- Maximum output current capacity for terminal 12V is 20mA.
- Multi-function analog output AO1 and AO2 are for use for an analog output meter. Do not use these output for feedback control.
- Control board's 24V and $\pm 12V$ are to be used for internal control only, Do not use the internal power-supply to power external devices.

3.9 Power Terminals

Terminal	230V: 0.5 ~ 20HP 460V: 1 ~ 25HP
L1(L)	Input Power Supply (For single phase use terminals L1(L) and L3(N))
L2	
L3(N)	
P	Braking resistor connection terminal: For use in applications requiring a high inertia load to stop rapidly. (Refer to specifications of the braking resistor).
BR	
T1	Inverter output, connect to U/V/W terminals of motor
T2	
T3	
	Ground terminal

230V: 0.5 ~ 1HP (Single Phase)

230V: 0.5 ~ 1HP (Single/Three Phase)

230V 2HP, 460V 1~2HP (Three Phase)

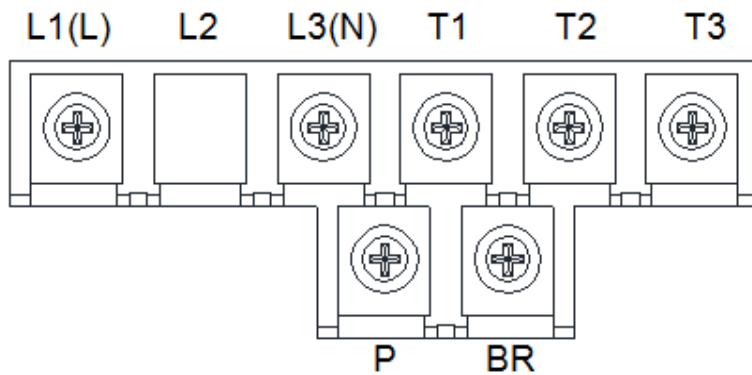

Frame 2

230V: 2 ~ 3HP (Single Phase)

230V: 2 ~ 3HP (Single / Three Phase)

230V: 5HP (Three Phase)

460V: 3 ~ 5HP (Three Phase)

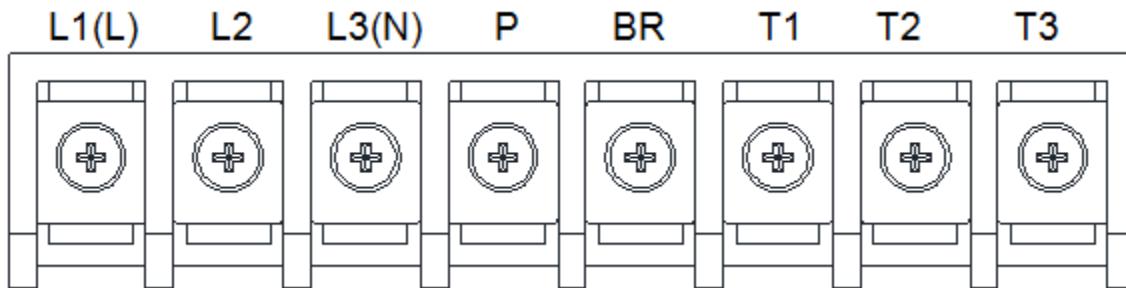

Frame 3 & 4

230V: 7.5 ~ 20HP (Three Phase)

460V: 7.5 ~ 25HP (Three Phase)

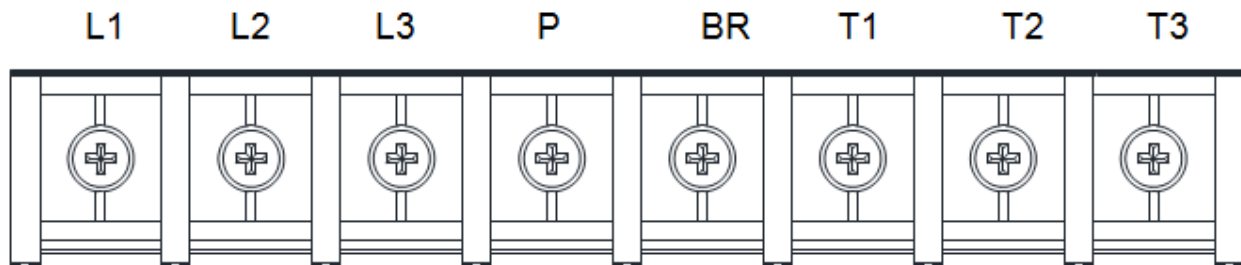

Notes: For wire gauges and screw torques, please refer to the table in section 3.6.

3.10 Inverter Wiring

Wiring Precautions

 Danger	<ul style="list-style-type: none">• Do NOT remove any protective covers or attempt any wiring while input power is applied. Connect all wiring before applying input power. When making wiring changes after power up, remove input power and wait a minimum of five minutes after power has been turned off before starting. Also confirm that the charge lamp is off and that DC voltage between terminals B1/P or (+) and (-) does not exceed 25V, otherwise electric shock may result.• Only authorized personnel should work on the equipment. (Take off metal jewelry such as watches and rings and use insulated tools.), otherwise electric shock or injury may result.
---	---

(A) Power input terminals

1. The Input power supply voltage can be connected in any phase sequence to power input terminals R/L1, S/L2, or T/L3 on the terminal block.
2. DO NOT connect the AC input power source to the output terminals U/T1, V/T2 and. W/T3.
3. Connect the output terminals U/T1, V/T2, W/T3 to motor lead wires U/T1, V/T2, and W/T3, respectively.
4. Check that the motor rotates forward with the forward run source. If it does not, swap any 2 of the output cables to change motor direction.
5. DO NOT connect phase correcting capacitors or LC/RC noise filter to the output circuit.

Example power connections:

Inverter with dedicated power line

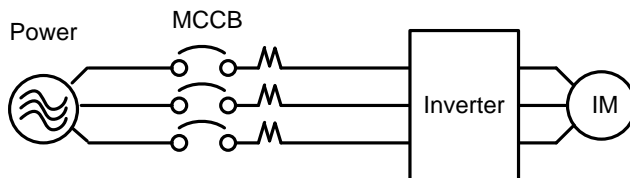

Install a Supply RFI filter or Isolation transformer when the power source is shared with other high power electrical equipment as shown below.

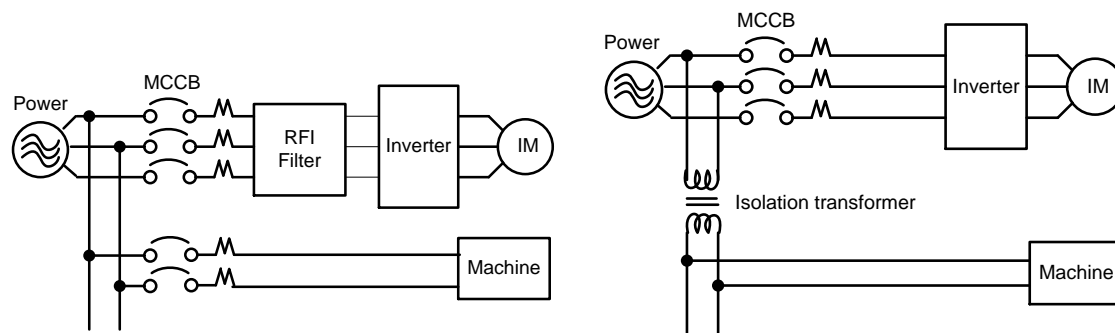

(B) Grounding

1. Connect the ground terminal (E) to ground having a resistance of less than 100Ω .
2. Do not share the ground wire with other devices, such as welding machines or power tools.
3. Always use a ground wire that complies with the local codes and standards for electrical equipment and minimize the length of ground wire.
4. When using more than one inverter, be careful not to loop the ground wire, as shown below in Fig. 3.11.1.

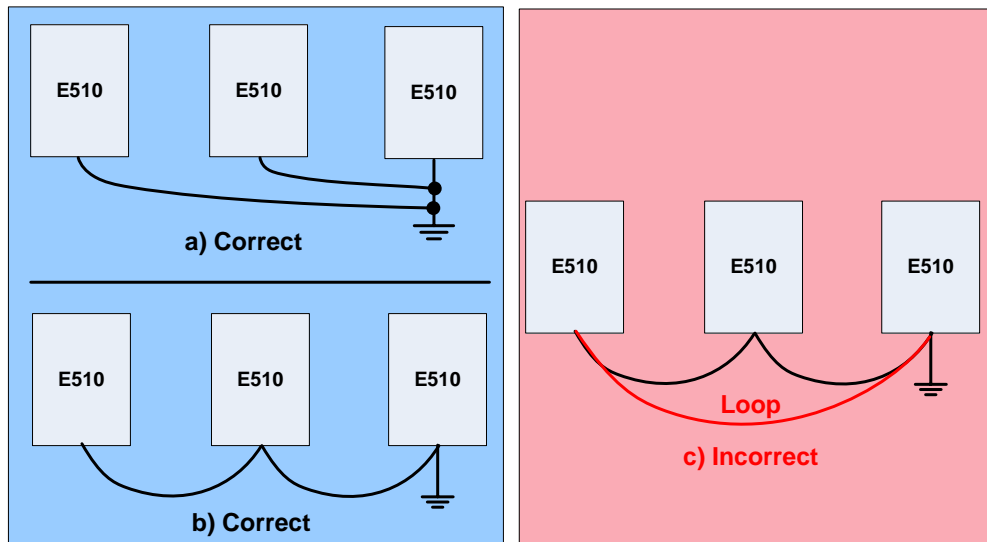

Fig. 3.11.1 Inverter Grounding

3.11 Input Power and Motor Cable Length

The length of the cables between the input power source and /or the motor and inverter can cause a significant phase to phase voltage reduction due to the voltage drop across the cables. The wire size shown in Tables 3.16.1 is based on a maximum voltage drop of 2%. If this value is exceeded, a wire size having larger diameter may be needed. To calculate phase to phase voltage drop, apply the following formula:

$$\text{Phase-to-phase voltage drop (V)} = \sqrt{3} \times \text{resistance of wire } (\Omega/\text{km}) \times \text{length of line (m)} \times \text{current} \times 10^{-3}.$$

(km=3280 x feet)

(m=3.28 x feet)

3.12 Cable Length vs. Carrier Frequency

The allowable setting of the PWM carrier frequency is also determined by motor cable length and is specified in the following Table 3.13.1.

Table 3.13.1 Cable Length vs. Carrier Frequency

Cable length between the inverter and Motor in m (ft.).	< 30m (100)	30 – 50 (100 – 165)	50 – 100 (166 - 328)	≥ 100 (329)
Recommended carrier frequency allowed Parameter 11-01	16kHz (max)	10 kHz (max)	5 kHz (max)	2 kHz (max)

3.13 Installing an AC Line Reactor

If the inverter is connected to a large-capacity power source (600kVA or more), install an optional AC reactor on the input side of the inverter. This also improves the power factor on the power supply side.

3.14 Power Input Wire Size, and NFB

The following table shows the recommended wire size for each frame of the E510. It depends on the application whether or not to install a circuit breaker. The NFB must be installed between the input power supply and the inverter input (L1 (L), L2, L3 (N)).

Note: When using a ground protection make sure the current setting is above 200mA and trip delay time is 0.1 sec of higher.

Table 3.16.1 Wiring instrument for frame 1 ~ 4

Model	TM1					TM2				
	Cable Size		Tightening torque			Cable Size		Tightening torque		
	AWG	mm ²	kgf.cm	lbf.in	Nm	AWG	mm ²	kgf.cm	lbf.in	Nm
Frame1	20~12	0.52~3.33	10.20	0.006	1.0	26~14	0.13~2.08	8.16	0.005	0.8
Frame2	18~8	0.81~8.37	18.35	0.010	1.8					
Frame3	14~6	2.08~13.30	24.47	0.014	2.4					
Frame4	4~3	21.15~26.67								

3.15 Control Circuit Wiring

- (1) Separate the wiring for control circuit terminals from main circuit wiring for terminals (R/L1, S/L2, T/L3, U/T1, V/T2, W/T3).
- (2) Separate the wiring for control circuit terminals R1A-R1B-R1C or R2A, R2B (Relay outputs) from wiring for terminals S1 – S6, A0, AGND, +10V, AI1, AI2 and GND wiring.
- (3) Use shielded twisted-pair cables (#24 - #14 AWG / 0.5 -2 mm²) shown in Fig. 3.17.1 for control circuits to minimize noise problems. The maximum wiring distance should not exceed 50m (165 ft).

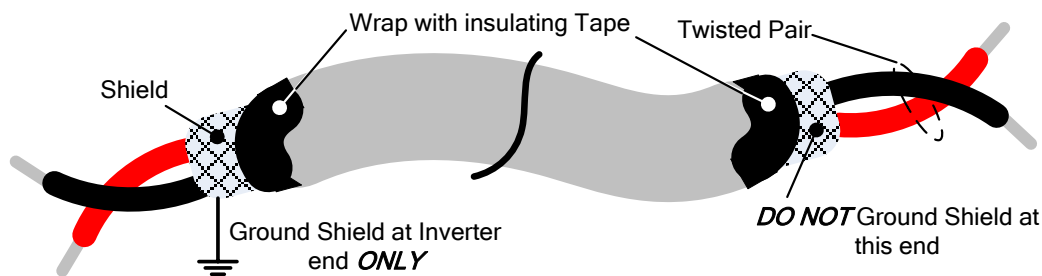

Fig. 3.17.1 Shielded Twisted-Pair

3.16 Inverter Specification

Product Specifications 230V class – Single Phase

Model:E510-□□□- H1F(N4)(S)	2P5	201	202	203
Horse power (HP)	0.5	1	2	3
Suitable motor capacity (kW)	0.4	0.75	1.5	2.2
Rated output current (A)	3.1	4.5	7.5	10.5
Rated capacity (KVA)	1.2	1.7	2.90	4.00
Input voltage range(V)	Single Phase:200~240V,50/60Hz			
Allowable voltage fluctuation	+10%-15%			
Output voltage range(V)	Three phase: 0~240V			
Input current (A)*	8.5	12	16	23.9
Inverter net weight (kg)	1.65	1.65	2.5	2.5
Allowable momentary power loss time (S)	2.0	2.0	2.0	2.0
Enclosure	IP66/NEMA4X			

Product Specifications 230V class – Single/Three Phase

Model:E510-□□□- H(N4R)	2P5	201	202	203
Horse power (HP)	0.5	1	2	3
Suitable motor capacity (kW)	0.4	0.75	1.5	2.2
Rated output current (A)	3.1	4.5	7.5	10.5
Rated capacity (KVA)	1.2	1.7	2.90	4.00
Input voltage range(V)	Single/Three Phase:200~240V, 50/60Hz			
Allowable voltage fluctuation	+10%-15%			
Output voltage range(V)	Three phase: 0~240V			
Input current (A)*	8.5/4.5	12/6.5	16/11	23.9/12.5
Inverter net weight (kg)	1.6	1.6	2.5	2.5
Allowable momentary power loss time (S)	2.0	2.0	2.0	2.0
Enclosure	IP66/NEMA4X			

Product Specifications 230V class –Three Phase

Model: E510-□□□- H3(N4)	202	205	208	210	215	220
Horse power (HP)	2	5	7.5	10	15	20
Suitable motor capacity (kW)	1.5	3.7	5.5	7.5	11	15
Rated output current (A)	7.5	17.5	26	35	48	64
Rated capacity (KVA)	2.9	6.7	9.9	13.3	20.6	27.4
Input voltage range(V)	Three phase :200~240V,50/60HZ					
Allowable voltage fluctuation	+10%-15%					
Output voltage range(V)	Three phase: 0~240V					
Input current (A)*	11	20.5	33	42	57	70
Inverter net weight (kg)	1.6	2.5	6.5	6.5	10.1	10.4
Allowable momentary power loss time (S)	2.0	2.0	2.0	2.0	2.0	2.0
Enclosure	IP66/NEMA4X					

Product Specifications 460V class –Three Phase

Model:E510-□□□- H3(F)(N4)(S)	401	402	403	405
Horse power (HP)	1	2	3	5
Suitable motor capacity (kW)	0.75	1.5	2.2	3.7
Rated output current (A)	2.3	3.8	5.2	8.8
Rated capacity (KVA)	1.7	2.9	4.0	6.7
Input voltage range(V)	Three phase: 380~480V,50/60Hz			
Allowable voltage fluctuation	+10%-15%			
Output voltage range(V)	Three phase:0~480V			
Input current (A)*	4.2	5.6	7.3	11.6
Inverter net weight (kg)	1.7	1.7	2.5	2.5
Allowable momentary power loss time (S)	2.0	2.0	2.0	2.0
Enclosure	IP66/NEMA4X			

Product Specifications 460V class –Three Phase

Model:E510-□□□- H3(F)(N4)(S)	408	410	415	420	425
Horse power (HP)	7.5	10	15	20	25
Suitable motor capacity (kW)	5.5	7.5	11	15	18.5
Rated output current (A)	13.0	17.5	24	32	40
Rated capacity (KVA)	9.9	13.3	19.1	27.4	34
Input voltage range(V)	Three phase: 380~480V,50/60Hz				
Allowable voltage fluctuation	+10%-15%				
Output voltage range(V)	Three phase: 0~480V				
Input current (A)*	17	23	31	38	48
Inverter net weight (kg)	6.7	6.7	6.7	13.7	13.7
Allowable momentary power loss time (S)	2.0	2.0	2.0	2.0	2.0
Enclosure	IP66/NEMA4X				

Product Specifications 460V class –Three Phase

Model: E510-□□□- H3(F)(PT)	420	425
Horse power (HP)	20	25
Suitable motor capacity (kW)	15	18.5
Rated output current (A)	32	40
Rated capacity (KVA)	27.4	34
Input voltage range(V)	Three phase: 380~480V (+10%-15%),50/60Hz	
Output voltage range(V)	Three phase: 0~480V	
Input current (A)*	38	48
Allowable momentary power loss time (S)	2.0	2.0
Enclosure	IP66/NEMA4X	

Notes:

*The input current is calculated value at full rated output current.

*N4S 460V series only up to 15HP.

N4: Protection class IP66, without built-in disconnect switches and VR.

N4R: Protection class IP66, with built-in VR, without disconnect switches

N4S: Protection class IP66, with built-in disconnect switches and VR

General Specifications

Item		E510
Control Mode		V/F Control, Vector Control
Frequency	Output Frequency	0.01~650.00Hz
	Starting Torque	150%/1Hz(Vector)
	Speed Control Range	1:50
	Setting resolution	Digital input: 0.01Hz
		Analog input:0.06Hz/60Hz
	Setting	Keypad: Set directly with ▲ ▼ keys or the VR on the keypad
		External Input Terminals: AI1(0/2~10V), AI2(0/4~20mA)input Multifunction input up/down function(Group3) Setting frequency by communication method.
Frequency limit	Lower and upper frequency limits, 3 skip frequency settings.	
Run	Operation set	Keypad run, stop button
		External terminals: Multi- operation-mode2 / 3 wire selection Jog operation
		Run signal by communication method.
Main Control Features	V / F curve setting	18 fixed curves and one customized curve
	Carrier frequency	1~16KHz
	Acceleration and deceleration control	2 Acceleration / deceleration time parameters. 4 off S curve parameters.
	Multifunction input	29 functions (refer to description on group3)
	Multifunction output	21 functions (refer to description on group3)
	Multifunction analog output	5 functions (refer to description on group4)
	Main features	Overload Detection,16 preset speeds, Auto-run, Acc/Dec Switch (2 Stages),Main/Alt run Command select, Main/Alt Frequency Command selection, PID control, torque boost, V/F start Frequency, Fault reset, Firemode.
Display	LED	Display: parameter / parameter value / frequency / line speed / DC voltage / output voltage / output current / PID feedback / input and output terminal status / Heat sink temperature / Program Version / Fault Log.
	LED Status Indicator	Run / Stop / Forward / Reverse ,and etc.
Protective Functions	Overload Protection	The relays to protect the motor and the inverter. (150%/1min)
	Over voltage	·220V: >410V ,380V: >820V
	Under Voltage	·220V: <190V , 380V: <380V
	Momentary Power Loss Restart	Inverter auto-restart after a momentary power loss.
	Stall Prevention	Stall prevention for Acceleration/ Deceleration/ Operation.

	Short-circuit output terminal	Electronic Circuit Protection
	Grounding Fault	Electronic Circuit Protection
	Other protection features	Protection for overheating of heat sink, The carrier frequency decreases based on the temperature, Fault output, Reverse prohibit, Prohibit for direct start after power up and error recovery ,parameter lock up
	All frames include brake transistor	
Communication control		Standard built-in RS485 communication (Modbus), One to one or One to many control.
Environment	Operating temperature	-10~50°C (Note1)
	Storage temperature	-20~60°C
	Humidity	95% RH or less (no condensation) (Compliance with IEC 60068 - 2-78)
	Shock	20Hz or less 1G(9.8m/s ²)20~50Hz 0.6G(5.88m/s ²) (Compliance with IEC 60068 - 2-6)
	Enclosure	IP66/NEMA4X

Note1:

IP66/NEMA 4X Type:
-10~50°C

3.17 Inverter derating based on Carrier Frequency

Frame 1 / 2 / 3 / 4

Single phase: 230V: 0.5~3HP; Single /Three phase: 230V: 0.5~3HP;
Three phase: 230V: 2~20HP, 460V: 1~25HP)

Current Rating

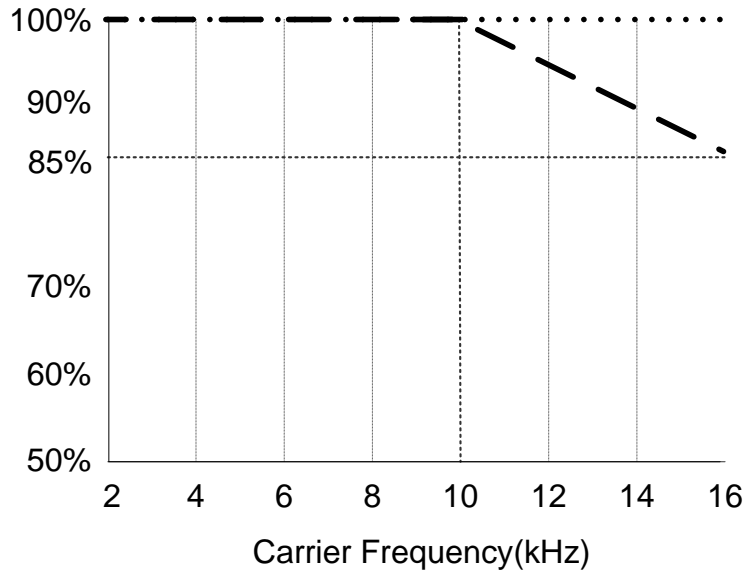

Note: De-rate curve for ambient temperature of 104°F (40°C).
----- De-rate curve for ambient temperature of 122°F (50°C).

3.18 Inverter Dimensions

IP66 / NEMA 4X Dimensions

Frame 1 (IP66 / NEMA 4X)

Single phase: 230V 0.5~1HP

Single / Three phase: 230V 0.5~1HP

Three Phase: 230V 2HP; 460V 1~2HP

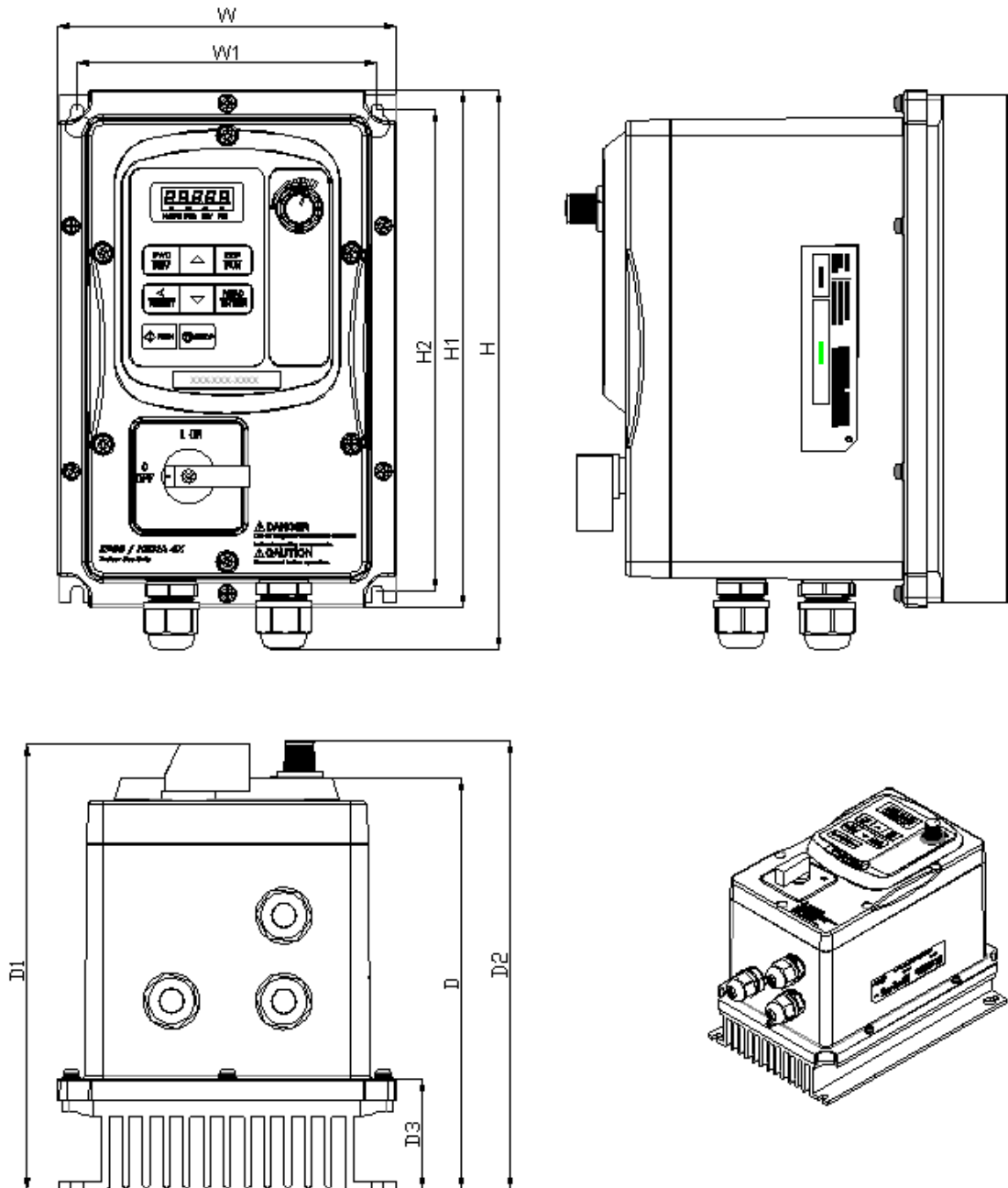

Unit: mm(inch)

Model	Dimensions												N.W (kg)
	W	W1	H	H1	H2	D	D1	D2	D3	Q1	Q2	Q3	
E510-2P5-HN4R	150.8 (5.94)	133.3 (5.25)	248.7 (9.79)	230.2 (9.06)	214.2 (8.43)	183 (7.20)		200 (7.87)	49.5 (1.95)	5.4 (0.21)	5.4 (0.21)	10.6 (0.42)	2.9
E510-2P5-H1FN4S							200 (7.87)	200 (7.87)					
E510-201-HN4R								200 (7.87)					
E510-201-H1FN4S							200 (7.87)	200 (7.87)					
E510-401-H3N4													
E510-401-H3FN4S							200 (7.87)	200 (7.87)					
E510-402-H3N4													
E510-402-H3FN4S							200	200					

Frame 2 (IP66 / NEMA 4X)

Single phase: 230V 2~3HP

Single / Three phase: 230V 2~3HP

Three Phase: 230V 5HP; 460V 3~5HP

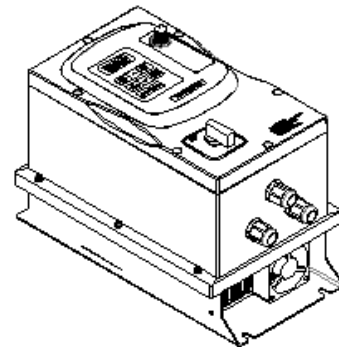
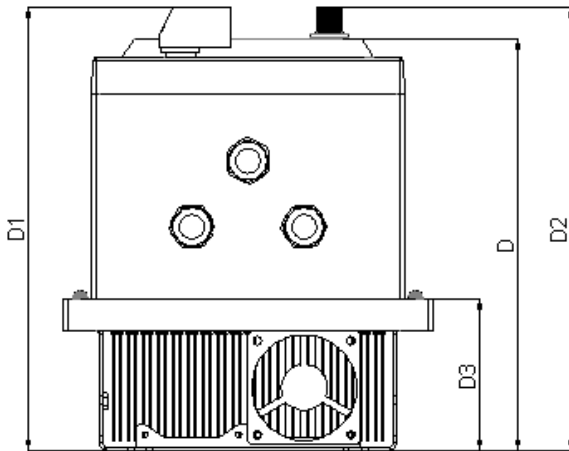
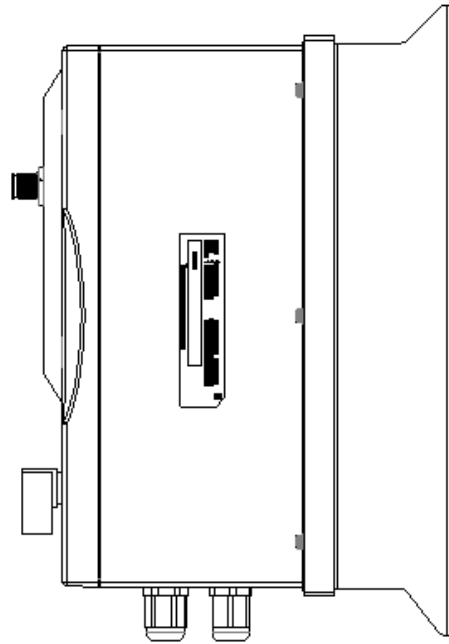
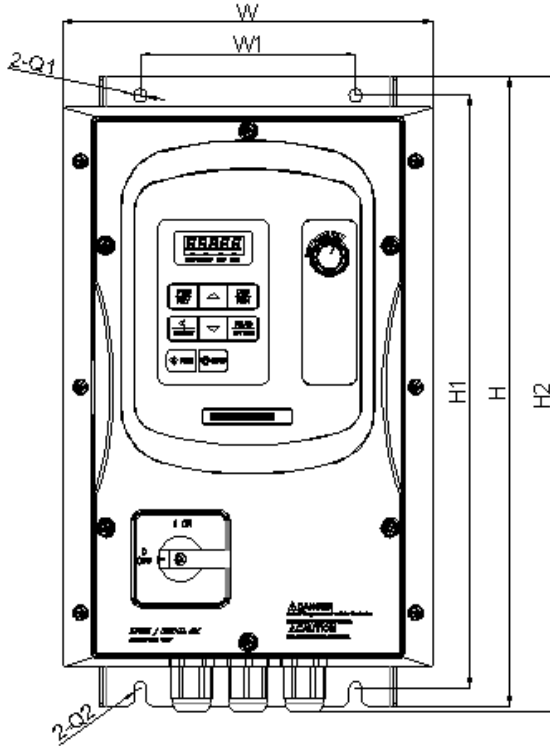

Unit: mm(inch)

Model	Dimensions											N.W (kg)
	W	W1	H	H1	H2	D	D1	D2	D3	Q1	Q2	
E510-202-HN4R	198 (7.80)	115 (4.53)	335 (13.19)	315 (12.40)	337.9 (13.30)	218.4 (8.60)		235.2 (9.26)	79.8 (3.14)	7 (0.28)	7 (0.28)	5.98
E510-202-H1FN4S								235.2 (9.26)				
E510-203-HN4R								235.2 (9.26)				
E510-203-H1FN4S								235.2 (9.26)				
E510-205-H3N4												
E510-403-H3N4												
E510-403-H3FN4S								235.2 (9.26)				
E510-405-H3N4												
E510-405-H3FN4S								235.2 (9.26)				

Frame 3 (IP66 / NEMA 4X)

Three Phase: 230V 7.5~20HP; 460V 7.5~25HP

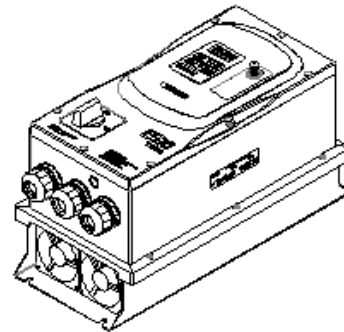
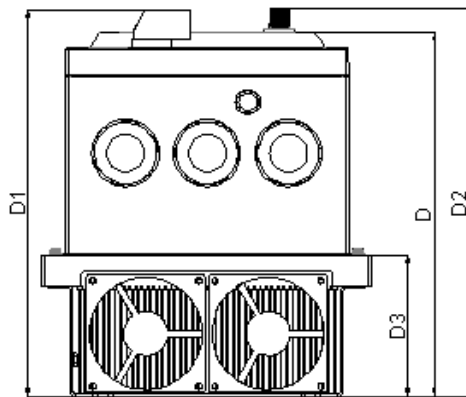
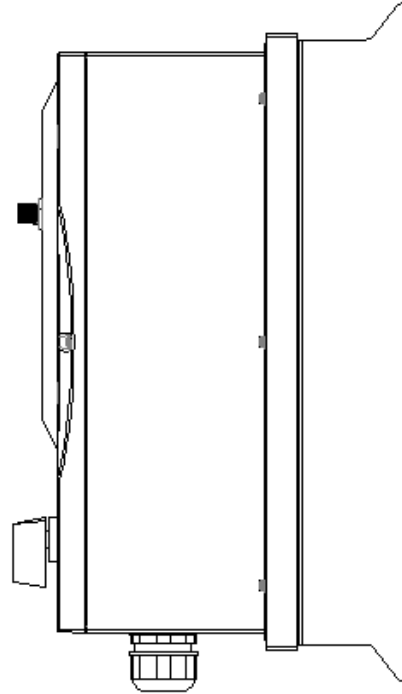
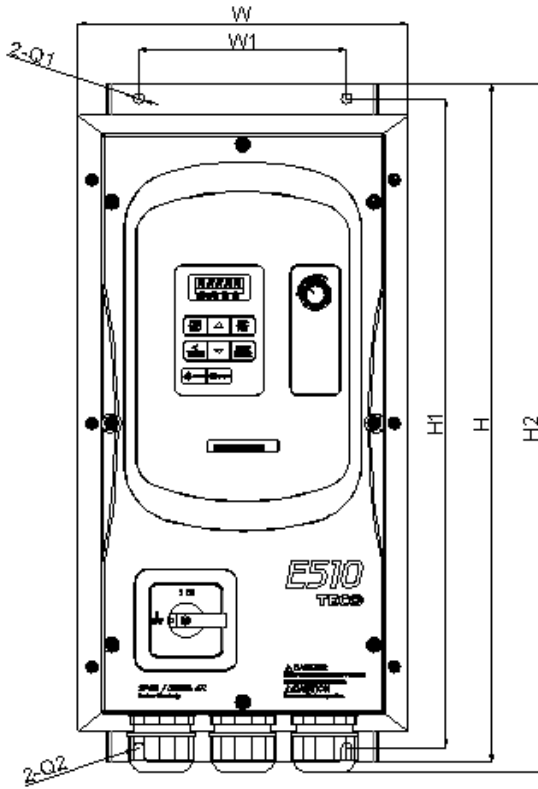

Unit: mm(inch)

Model	Dimensions											N.W (kg)
	W	W1	H	H1	H2	D	D1	D2	D3	Q1	Q2	
E510-208-H3N4	222.8 (8.77)	140 (5.51)	460 (18.11)	440 (17.32)	466.3 (18.36)	246.6 (9.71)			96 (3.78)	7 (0.28)	7 (0.28)	12.68
E510-210-H3N4												
E510-215-H3N4												
E510-220-H3N4												
E510-408-H3N4												
E510-408-H3FN4S							266.5 (10.49)	263.5 (10.37)				
E510-410-H3N4												
E510-410-H3FN4S							266.5 (10.49)	263.5 (10.37)				
E510-415-H3N4												
E510-415-H3FN4S							266.5 (10.49)	263.5 (10.37)				
E510-420-H3N4												
E510-425-H3N4												

4. Keypad and Programming Functions

4.1 LED Keypad

4.1.1 Keypad Display and Keys





DISPLAY	Description
5 Digit LED Display	Monitor inverter signals, view / edit parameters, fault / alarm display.
LED INDICATORS	
Hz/RPM	LED ON when frequency or line speed is displayed.
FWD	LED ON when inverter is running in forward direction, flashing when stopping.
REV	On when inverter is running in reverse direction, flashing when stopping.
FUN	LED ON when parameters are displayed.

KEYS (8)	Description
RUN	RUN Inverter in Local Mode
STOP	STOP Inverter
▲	Parameter navigation Up, Increase parameter or reference value
▼	Parameter navigation down, decrease parameter or reference value
FWD/REV	FWD: Forward Run / REV: Reverse Run
DSP/FUN	DSP: Switch between available display modes FUN: View/Edit parameter value
READ/ENTER	Used to display parameter settings and save parameter changed settings
< / RESET	Use to reset alarms or resettable faults



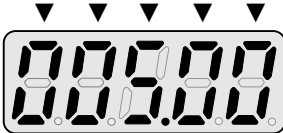





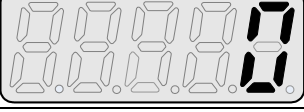

4.1.2 Display Description

Actual	LED Display	Actual	LED Display	Actual	LED Display	Actual	LED Display
0	0	A	A	L	L	Y	Y
1	1	B	b	n	n	-	-
2	2	C	C	o	0	°	□
3	3	D	d	P	P	_	-
4	4	E	E	q	q	.	
5	5	F	F	r	r		
6	6	G	G	S	5		
7	7	H	H	t	t		
8	8	I	l	u	u		
9	9	J	J	V	U		

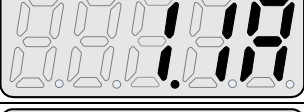
Display output frequency	Frequency Reference	Set Frequency Reference
LED lights on	LED flashes	Flashing digit
		



At power-up the display will show the frequency reference setting, all LEDs are flashing. Press the ▲UP or ▼DOWN key to enter the frequency reference edit mode, use the ◀/ENT key to select which digit to edit (flashing). Use the ▲UP or ▼DOWN key to modify the value. During run operation the display will show the output frequency.

LED display examples



Seven Segment display	Description
	1. Displays the frequency reference at power-up 2. Display the actual output frequency in operation status.
	Display parameter code
	Display the setting value of parameter
	Display input voltage
	Display inverter current.
	Display DC Bus Voltage
	Display temperature
	Display PID feedback value. The displayed digit is set by 12-01.
	Error display, refer to Chapter 5 Troubleshooting and maintenance
	Analog Current / Voltage AI1 / AI2. Range (0~1000)

4.1.3 LED Status description



Hz/ RPM LED

State	Description	Hz/RPM LED
Off	Display doesn't show frequency or line speed	
Illuminated	Display shows frequency or line speed	



Forward LED

State	Description	FWD LED
Off	Inverter in reverse direction	
Illuminated	Inverter is running in forward direction	
Flashing	Forward direction active, no run command	

Reverse LED

State	Description	REV LED
Off	Inverter in forward direction	
Illuminated	Inverter is running in reverse direction	
Flashing	Reverse direction active, no run command	

FUN LED

State	Description	FUN LED
Off	Display doesn't show parameter	
Illuminated	Display shows parameter	
Flashing	Firemode Enabled	

4.1.4 Power-Up Monitor

Power Up:

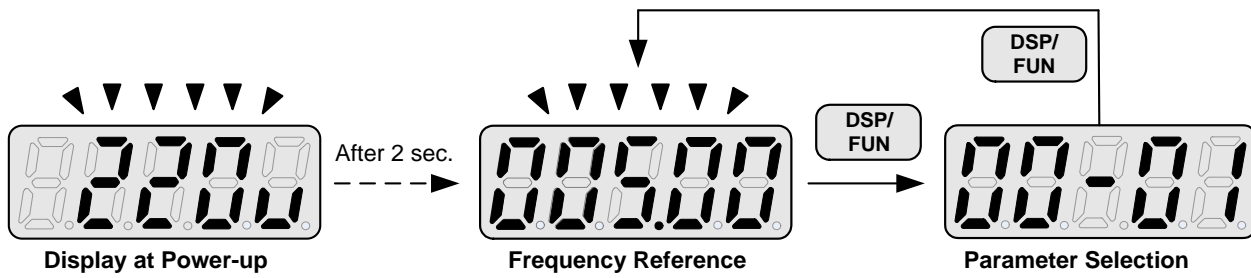

Change Monitor at Power-Up

12-00	Display selection
	<p>Highest bit -> 0 0 0 0 0 <- Lowest bit The setting range for each bit is 0 ~ 8 from the highest bit to the lowest bit.</p>
Range	<p>0: No display 4: Temperature 8: Count value 1: Output current 5: PID feedback 2: Output voltage 6: AI1 value 3: DC voltage 7: AI2 value</p>

Example: 12-00 = 10000

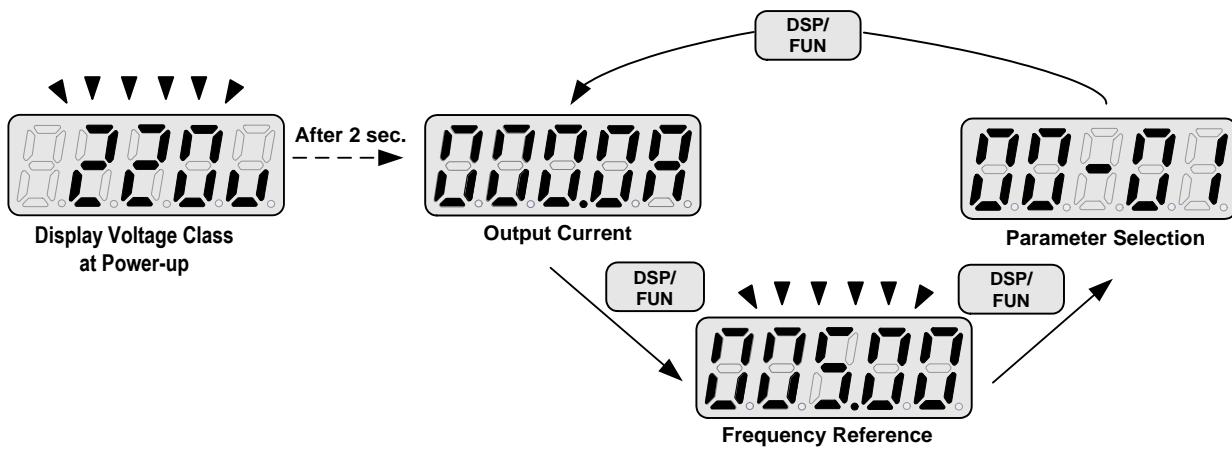

Example: 12-00 = 12345

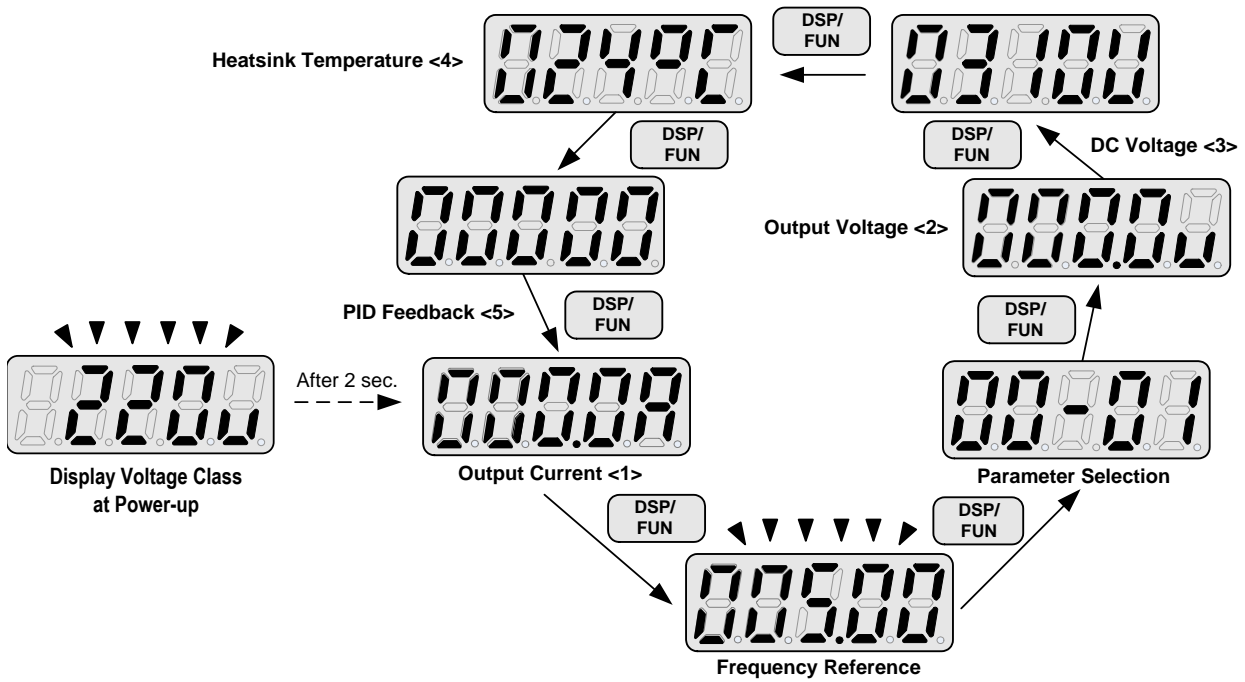

4.1.5 Modifying Parameters / Set Frequency Reference

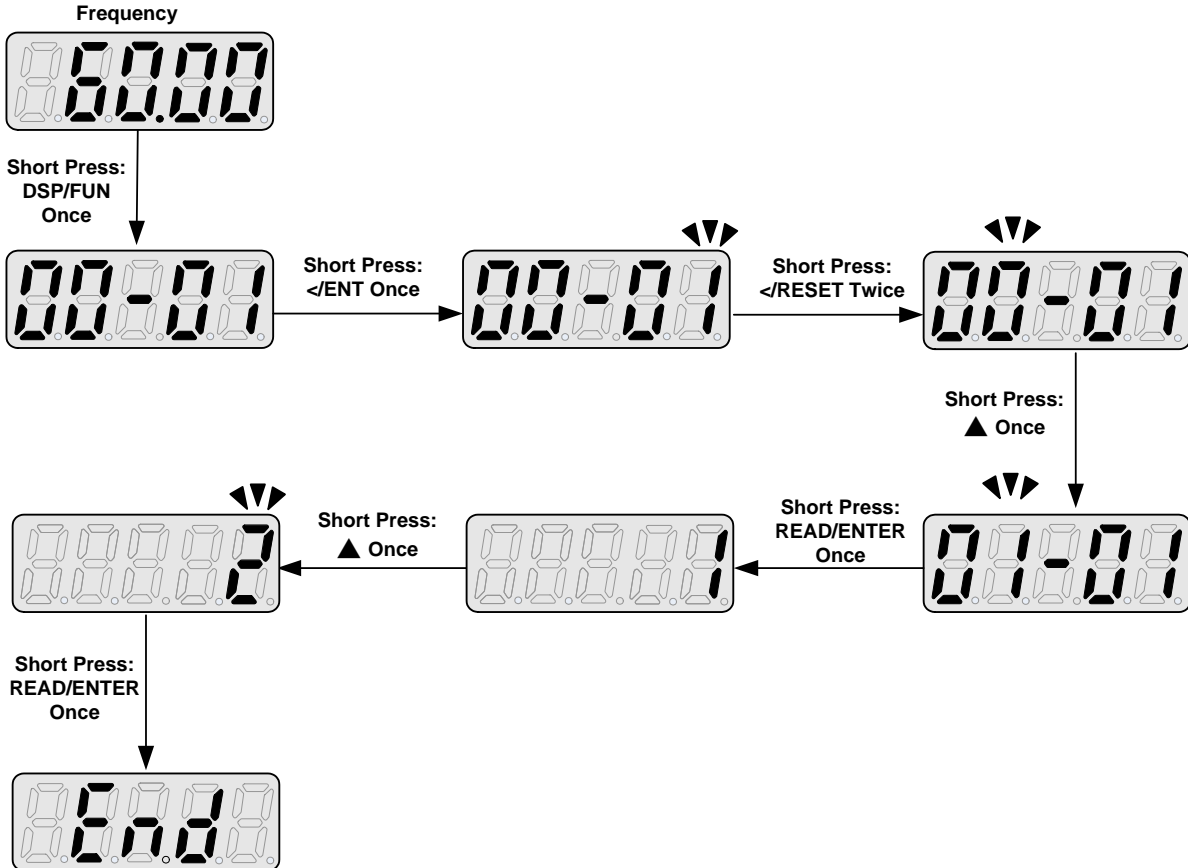

4.1.6 Operation Control

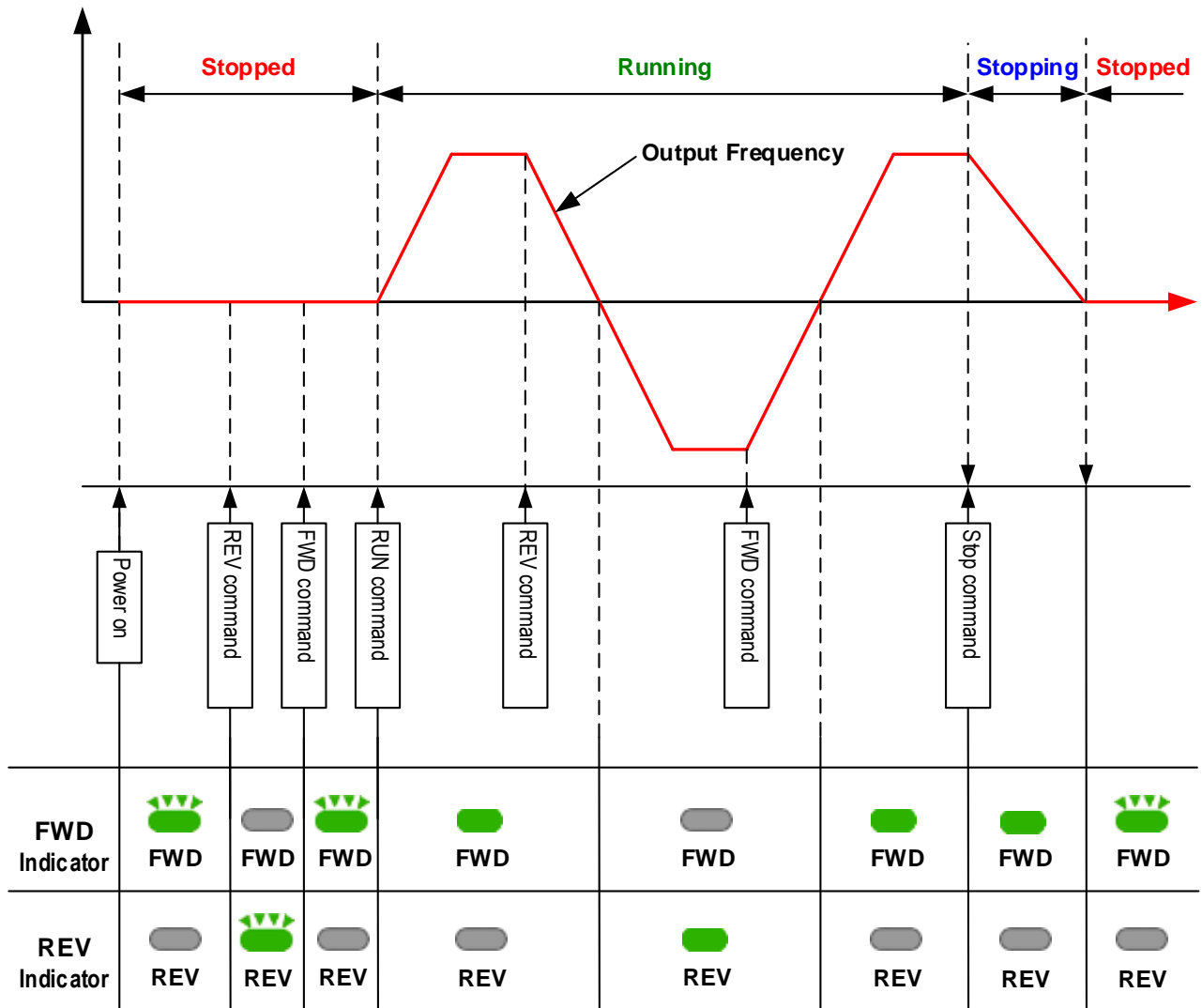

4.2 Parameters

Parameter group	Name
Group 00	Basic Parameters
Group 01	V/F Control Parameters
Group 02	Motor Parameters
Group 03	External Digital Input and Output Parameters
Group 04	External Analog Input and Output Parameters
Group 05	Preset-Speed Parameters
Group 06	Automatic Program Operation Parameters
Group 07	Start /Stop Parameters
Group 08	Protection Parameters
Group 09	Communication Parameters
Group 10	PID Parameters
Group 11	Performance Control Parameters
Group 12	Monitoring Parameters
Group 13	Maintenance Parameters
Group 14	PLC Parameters
Group 15	PLC Monitoring Parameters

Parameter Notes	
*1	Parameter can be adjusted during running mode
*2	Cannot be modified in communication mode
*3	Does not change with factory reset
*4	Read only
*5	Available for above V1.1
*6	Available for above V1.3
*7	Available for above V1.7

Group 00: Basic parameters					
No.	Description	Range	Factory Setting	Unit	Note
00-00	Control Mode Selection	0:V/F Mode	0	-	
		1:Vector Mode			
00-01	Reserved				
00-02	Main Run Command Source Selection	0:Keypad	0	-	
		1:External Run/Stop Control			
		2:Communication			
		3:PLC			
00-03	Alternative Run Command Source Selection	0:Keypad	0	-	
		1:External Run/Stop Control			
		2:Communication			
00-04	Operation Modes for External Terminals	0:Forward/Stop-Reverse/Stop	0	-	
		1:Run/Stop- Reverse/Forward			
		2: 3 Wire Control Mode-Run/Stop			
00-05	Main Frequency Command Source Selection	0:UP/DOWM of Keypad	0	-	
		1:Potentiometer on Keypad			
		2:External AI1 Analog Signal Input			
		3:External AI2 Analog Signal Input			
		4:External Up/Down Frequency Control			
		5:Communication Setting Frequency			
		6:PID Ouput Frequency			
		7:Pulse Input			
					*6
00-06	Alternative Frequency Command Source Selection	0:UP/DOWM of Keypad	4	-	
		1:Potentiometer on Keypad			
		2:External AI1 Analog Signal Input			
		3:External AI2 Analog Signal Input			
		4:External Up/Down Frequency Control			
		5:Communication Setting Frequency			
		6:PID Ouput Frequency			
		7:Pulse Input			
					*6
00-07	Main and Alternative Frequency Command Modes	0:Main or Alternative Frequency 1:Main Frequency+ Alternative Frequency	0	-	
00-08	Communication Frequency Command	0.00~650.00	60.00	Hz	*4
00-09	Frequency Command Save on Power Down	0: Disable	0	-	
		1: Enable			
00-10	Initial Frequency Selection (keypad mode)	0:by Current Frequency Command	0	-	
		1:by 0 Frequency Command			
		2:by 00-11			
00-11	Initial Frequency Setpoint	0.00~650.00	50.00/60.00	Hz	
00-12	Frequency Upper Limit	0.01~650.00	50.00/60.00	Hz	
00-13	Frequency Lower Limit	0.00~649.99	0.00	Hz	
00-14	Acceleration Time 1	0.1~3600.0	10.0	Sec	*1
00-15	Deceleration Time 1	0.1~3600.0	10.0	Sec	*1
00-16	Acceleration Time 2	0.1~3600.0	10.0	Sec	*1
00-17	Deceleration Time 2	0.1~3600.0	10.0	Sec	*1
00-18	Jog Frequency	0.00~650.00	2.00	Hz	*1*7
00-19	Jog Acceleration Time	0.1~3600.0	0.5	Sec	*1*7
00-20	Jog Deceleration Time	0.1~3600.0	0.5	Sec	*1*7

Group 01: V/F Control Parameters					
No.	Description	Range	Factory Setting	Unit	Note
01-00	Volts/Hz Patterns	0~18	0/9	-	
01-01	V/F Max voltage	200V:170.0~264.0 400V:323.0~528.0	220.0/440.0	Vac	
01-02	Max Frequency	0.20 ~ 650.00	50.00/60.00	Hz	
01-03	Max Frequency Voltage Ratio	0.0 ~ 100.0	100.0	%	
01-04	Mid Frequency 2	0.10 ~ 650.00	25.00/30.00	Hz	
01-05	Mid Frequency Voltage Ratio 2	0.0 ~ 100.0	50.0	%	
01-06	Mid Frequency 1	0.10 ~ 650.00	10.00/12.00	Hz	
01-07	Mid Frequency Voltage Ratio 1	0.0 ~ 100.0	20.0	%	
01-08	Min Frequency	0.10 ~ 650.00	0.50/0.60	Hz	
01-09	Min Frequency Voltage Ratio	0.0 ~ 100.0	1.0	%	
01-10	Volts/Hz Curve Modification (Torque Boost)	0 ~ 10.0	0.0	%	*1
01-11	V/F start Frequency	0.00~10.00	0.00	Hz	
01-12	Slip compensation gain	0.05~10.00	0.10	S	
01-13	V/F Mode Select	0 : Mode 0 1 : Mode 1	by models	-	

Group 02: IM Motor parameters					
No.	Description	Range	Factory Setting	Unit	Note
02-00	Motor No Load Current	0~[(Parameter 02-01)-0.1]	-	Amps(AC)	*3
02-01	Motor Rated Current (OL1)	0.2~100	-	A	*3
02-02	Motor rated Slip Compensation	0.0 ~ 200.0	0.0	%	*1
02-03	Motor rated speed	0~39000	-	Rpm	*3
02-04	Motor rated voltage	200V: 170.0~264.0 400V: 323.0~528.0	220.0/440.0	V	
02-05	Motor rated power	0.1~37.0	-	KW	
02-06	Motor rated frequency	0~650.0	50.0/60.0	Hz	
02-07	Motor pole number	2 ~16	4	-	
02-08 ~ 02-13	Reserved				
02-14	Auto Tune	0: Disable 1: Start Auto tune function.	0		
02-15	Stator resistance gain	----			*3*4
02-16	Rotor resistance gain	----			*3*4

Group 03: External Digital Inputs and Relay Output Functions					
No.	Description	Range	Factory Setting	Unit	Note
03-00	Multifunction Input Term. S1	0:Forward/Stop Command	0	-	
03-01	Multifunction Input Term. S2	1:Reverse/Stop Command	1	-	
03-02	Multifunction Input Term. S3	2:Speed Selection 1	2	-	
03-03	Multifunction Input Term. S4	3:Speed Selection 2	3	-	
03-04	Multifunction Input Term. S5	4:Speed Selection 3	4	-	
03-05	Multifunction Input Term. S6	5:Speed Selection 4	17		
		6:Jog Forward Command			
		7:Jog Reverse Command			
		8:Up Command			
		9:Down Command			
		10:Acc/Dec 2			
		11:Acc/Dec Disabled			
		12:Main/Alternative run source select			
		13:Main/ Alternative Frequency Command select			
		14:Rapid Stop (Decel to stop)			
		15:Base Block			
		16:Disabl PID Function			
		17:Fault Reset			
		18:Auto Run Mode Enable			
		19:Speed Search			
		20:Energy Saving (only V/F)			
		21:Reset PID integral value to Zero			
22:Counter Input					
23:Counter reset					
24:PLC Input					
25:Pulse Input-Width Measure (S3)	*6				
26:Pulse Input-Frequency Measure (S3)	*6				
27:Enable KEB Function					
28:Fire mode function	*5				
03-06	Up/Down frequency step	0.00~5.00	0.00	Hz	
03-07	Up/Down Keep Frequency Status after Stop Command	0:When Up/Down is used, the preset frequency is held as the inverter stops, and the UP/Down function is disabled	0	-	
		1:When Up/Down is used, the preset frequency is reset to 0 Hz as the inverter stops.			
		2:When Up/Down is used, the preset frequency is held as the inverter stops, and the UP/Down is available.			
03-08	S1 ~ S6 scan confirmation	1~200 Number of Scan cycles	10	2ms	
03-09	S1~ S5 switch type select	xxx0:S1 NO xxx1:S1 NC	00000	-	
		xxx0x:S2 NO xxx1x:S2 NC			
		xx0xx:S3 NO xx1xx:S3 NC			
		x0xxx:S4 NO x1xxx:S4 NC			
		0xxxx:S5 NO 1xxxx:S5 NC			
03-10	S6 switch type select	xxx0:S6 NO xxx1:S6 NC	00000	-	
03-11	Output Relay RY1	0:Run	0	-	

Group 03: External Digital Inputs and Relay Output Functions					
No.	Description	Range	Factory Setting	Unit	Note
	(Terminals R1A,R1B, R1C)				
03-12	Output Relay RY2. (Terminals R2A, R2B)	1:Fault	1		
		2:Setting Frequency Reached			
		3:Frequency Reached. Set by (3-13±3-14)			
		4:Output Frequency Detection1(> 3-13)			
		5:Output Frequency Detection2(< 3-13)			
		6:Auto Restart			
		7:Momentary AC Power Loss			
		8:Rapid Stop			
		9:Base Block			
		10:Motor Overload Protection(OL1)			
		11:Drive Overload Protection(OL2)			
		12:Over-torque Threshold Level (OL3)			
		13:Preset Output Current Reached (03-15~16)			
		14:Brake Control (03-17~18)			
		15:PID Feedback Signal Loss			
		16: Single pre-set count (3-22)			
		17: Dual pre-set count (3-22~23)			
		18:PLC Status Indicator (00-02)			
		19:PLC control			
		20:Zero Speed			
03-13	Frequency Reached Level	0.00~650.00	0.00	Hz	*1
03-14	Frequency Reached Detection Range (±)	0.00~30.00	2.00	Hz	*1
03-15	Preset output current reached	0.1~15.0	0.1	A	
03-16	Preset output Current detection delay Time	0.1~10.0	0.1	Sec	
03-17	Brake Release level	0.00~20.00	0.00	Hz	
03-18	Brake Engage Level	0.00~20.00	0.00	Hz	
03-19	Relay Output function type	0:A (Normally open) 1:B (Normally close)	0	-	
03-20	Internal / external multi-function input terminal selection	0~63	0	-	
03-21	Action to set the internal multi-function input terminals	0~63	0	-	
03-22	Pre-set count 1	0~9999	0	-	
03-23	Pre-set count 2	0~9999	0	-	
03-24	Output under current detection	0:Disable	0	-	
		1:Enable			
03-25	Output under current detection level	5%~100%	20%	%	
03-26	Output under current detection delay time	0.0~50.0s	20.0	Sec	
03-27	Pulse Frequency	0.01~0.20	0.1	kHz	*7
03-28	Pulse Frequency Gain	0.01~9.99	1.00		*6

※ “NO” indicates normally open, “NC” indicates normally closed.

Group 04: External Analog Input and Output Parameters					
No.	Description	Range	Factory Setting	Unit	Note
04-00	Analog Input Signal Type Select (AI1/AI2)	AI1 AI2	1	-	*7
		(0): 0~10V (0~20mA) 0~10V (0~20mA)			
		(1): 0~10V (0~20mA) 2~10V (4~20mA)			
		(2): 2~10V (4~20mA) 0~10V (0~20mA)			
	(3): 2~10V (4~20mA) 2~10V (4~20mA)				
04-01	AI1 Signal Verification Scan Rate	1~200	50	2ms	
04-02	AI1 Gain	0 ~ 1000	100	%	*1
04-03	AI1 Bias	0 ~ 100	0	%	*1
04-04	AI1 Bias Selection	0: Positive 1: Negative	0	-	*1
04-05	AI1 Slope	0: Positive 1: Negative	0	-	*1
04-06	AI2 Signal Verification Scan Rate	1~200	50	2ms	
04-07	AI2 Gain	0 ~ 1000	100	%	*1
04-08	AI2 Bias	0 ~ 100	0	%	*1
04-09	AI2 Bias Selection	0: Positive 1: Negative	0	-	*1
04-10	AI2 Slope	0: Positive 1: Negative	0	-	*1
04-11	Analog Output (AO) Mode	0: Output Frequency 1: Frequency Command 2: Output Voltage 3: DC Bus Voltage 4: Motor Current (100% rated current)	0	-	*1
04-12	Analog Output (AO) Gain	0 ~ 1000	100	%	*1
04-13	Analog Output (AO) Bias	0 ~ 100	0	%	*1
04-14	AO Bias Selection	0: Positive 1: Negative	0	-	*1
04-15	AO Slope	0: Positive 1: Negative	0	-	*1
04-16	F-Gain Function	0: Invalid 1: Effective	0	-	*1

Group 05: Preset Speed Parameters					
No.	Description	Range	Factory Setting	Unit	Note
05-00	Preset Speed Control Mode Selection	0: Common Accel/Decel Accel/Decel 1 or 2 apply to all speeds	0	-	
		1: Individual Accel/Decel for each preset speed 0-15 apply to the selected preset speeds (Acc0/Dec0~Acc15/Dec15)			
05-01	Preset Speed 0 (Keypad Freq)	0.00 ~ 650.00	5.00	Hz	
05-02	Preset Speed1 (Hz)		5.00	Hz	*1
05-03	Preset Speed2 (Hz)		10.00	Hz	*1
05-04	Preset Speed3 (Hz)		20.00	Hz	*1
05-05	Preset Speed4 (Hz)		30.00	Hz	*1
05-06	Preset Speed5 (Hz)		40.00	Hz	*1
05-07	Preset Speed6 (Hz)		50.00	Hz	*1
05-08	Preset Speed7 (Hz)		50.00	Hz	*1
05-09	Preset Speed8 (Hz)		0.00	Hz	*1
05-10	Preset Speed9 (Hz)		0.00	Hz	*1
05-11	Preset Speed10 (Hz)		0.00	Hz	*1
05-12	Preset Speed11 (Hz)		0.00	Hz	*1
05-13	Preset Speed12 (Hz)		0.00	Hz	*1
05-14	Preset Speed13 (Hz)		0.00	Hz	*1
05-15	Preset Speed14 (Hz)		0.00	Hz	*1
05-16	Preset Speed15 (Hz)		0.00	Hz	*1
05-17	Preset Speed0-Acctime	0.1 ~ 3600.0	10.0	Sec	*1
05-18	Preset Speed0-Dectime		10.0	Sec	*1
05-19	Preset Speed1-Acctime		10.0	Sec	*1
05-20	Preset Speed1-Dectime		10.0	Sec	*1
05-21	Preset Speed2-Acctime		10.0	Sec	*1
05-22	Preset Speed2-Dectime		10.0	Sec	*1
05-23	Preset Speed3-Acctime		10.0	Sec	*1
05-24	Preset Speed3-Dectime		10.0	Sec	*1
05-25	Preset Speed4-Acctime		10.0	Sec	*1
05-26	Preset Speed4-Dectime		10.0	Sec	*1
05-27	Preset Speed5-Acctime		10.0	Sec	*1
05-28	Preset Speed5-Dectime		10.0	Sec	*1
05-29	Preset Speed6-Acctime		10.0	Sec	*1
05-30	Preset Speed6-Dectime		10.0	Sec	*1
05-31	Preset Speed7-Acctime		10.0	Sec	*1
05-32	Preset Speed7-Dectime		10.0	Sec	*1
05-33	Preset Speed8-Acctime		10.0	Sec	*1
05-34	Preset Speed8-Dectime		10.0	Sec	*1
05-35	Preset Speed9-Acctime		10.0	Sec	*1
05-36	Preset Speed9-Dectime		10.0	Sec	*1
05-37	Preset Speed10-Acctime		10.0	Sec	*1
05-38	Preset Speed10-Dectime		10.0	Sec	*1
05-39	Preset Speed11-Acctime	10.0	Sec	*1	

Group 05: Preset Speed Parameters					
No.	Description	Range	Factory Setting	Unit	Note
05-40	Preset Speed11-Decitime		10.0	Sec	*1
05-41	Preset Speed12-Acctime		10.0	Sec	*1
05-42	Preset Speed12-Decitime		10.0	Sec	*1
05-43	Preset Speed13-Acctime		10.0	Sec	*1
05-44	Preset Speed13-Decitime		10.0	Sec	*1
05-45	Preset Speed14-Acctime		10.0	Sec	*1
05-46	Preset Speed14-Decitime		10.0	Sec	*1
05-47	Preset Speed15-Acctime		10.0	Sec	*1
05-48	Preset Speed15-Decitime		10.0	Sec	*1

Group 06: Automatic Program Operation Parameters					
No.	Description	Range	Factory Setting	Unit	Note
06-00	Auto Run Mode Selection (Sequencer)	0: Disabled. 1: Single cycle. (Continues to run from the Unfinished step if restarted). 2: Periodic cycle. (Continues to run from the unfinished step if restarted). 3: Single cycle, then holds the speed Of final step to run. (Continues to run from the unfinished step if restarted). 4: Single cycle. (Starts a new cycle if restarted). 5: Periodic cycle. (Starts a new cycle if restarted). 6: Single cycle, then hold the speed of final step to run. (Starts a new cycle if restarted).	0	-	
06-01	Auto _ Run Mode Frequency Command 1	0.00~650.00	0.00	Hz	*1
06-02	Auto _ Run Mode Frequency Command 2		0.00	Hz	*1
06-03	Auto _ Run Mode Frequency Command 3		0.00	Hz	*1
06-04	Auto _ Run Mode Frequency Command 4		0.00	Hz	*1
06-05	Auto _ Run Mode Frequency Command 5		0.00	Hz	*1
06-06	Auto _ Run Mode Frequency Command 6		0.00	Hz	*1
06-07	Auto _ Run Mode Frequency Command 7		0.00	Hz	*1
06-08	Auto _ Run Mode Frequency Command 8		0.00	Hz	*1

06-09	Auto _ Run Mode Frequency Command 9		0.00	Hz	*1
06-10	Auto _ Run Mode Frequency Command10		0.00	Hz	*1
06-11	Auto _ Run Mode Frequency Command 11		0.00	Hz	*1
06-12	Auto _ Run Mode Frequency Command 12		0.00	Hz	*1
06-13	Auto _ Run Mode Frequency Command 13		0.00	Hz	*1
06-14	Auto _ Run Mode Frequency Command 14		0.00	Hz	*1
06-15	Auto _ Run Mode Frequency Command 15		0.00	Hz	*1
06-16	Auto_ Run Mode Running Time Setting 0		0.0	Sec	
06-17	Auto_ Run Mode Running Time Setting 1		0.0	Sec	
06-18	Auto_ Run Mode Running Time Setting 2		0.0	Sec	
06-19	Auto_ Run Mode Running Time Setting 3		0.0	Sec	
06-20	Auto_ Run Mode Running Time Setting 4	0 ~ 3600.0	0.0	Sec	
06-21	Auto_ Run Mode Running Time Setting 5		0.0	Sec	
06-22	Auto_ Run Mode Running Time Setting 6		0.0	Sec	
06-23	Auto_ Run Mode Running Time Setting 7		0.0	Sec	
06-24	Auto_ Run Mode Running Time Setting 8		0.0	Sec	
06-25	Auto_ Run Mode Running Time Setting 9		0.0	Sec	
06-26	Auto_ Run Mode Running Time Setting 10		0.0	Sec	
06-27	Auto_ Run Mode Running Time Setting 11		0.0	Sec	
06-28	Auto_ Run Mode Running Time Setting 12		0.0	Sec	
06-29	Auto_ Run Mode Running Time Setting 13		0.0	Sec	
06-30	Auto_ Run Mode Running Time Setting 14		0.0	Sec	
06-31	Auto_ Run Mode Running Time Setting 15		0.0	Sec	

06-32	Auto_Run Mode Running Direction 0	0: Stop 1: Forward 2: Reverse	0	-	
06-33	Auto_Run Mode Running Direction 1		0	-	
06-34	Auto_Run Mode Running Direction 2		0	-	
06-35	Auto_Run Mode Running Direction 3		0	-	
06-36	Auto_Run Mode Running Direction 4		0	-	
06-37	Auto_Run Mode Running Direction 5		0	-	
06-38	Auto_Run Mode Running Direction 6		0	-	
06-39	Auto_Run Mode Running Direction 7		0	-	
06-40	Auto_Run Mode Running Direction 8		0	-	
06-41	Auto_Run Mode Running Direction 9		0	-	
06-42	Auto_Run Mode Running Direction10		0	-	
06-43	Auto_Run Mode Running Direction 11		0	-	
06-44	Auto_Run Mode Running Direction12		0	-	
06-45	Auto_Run Mode Running Direction13		0	-	
06-46	Auto_Run Mode Running Direction 14		0	-	
06-47	Auto_Run Mode Running Direction 15		0	-	

※Frequency of the step 0 is set by parameter 05-01, keypad frequency.

Group 07: Start/Stop Parameters					
No.	Description	Range	Factory Setting	Unit	Note
07-00	Momentary Power Loss and Restart	0: Momentary Power Loss and Restart Disable 1: Momentary Power Loss and Restart Enable	0	-	
07-01	Auto Restart Delay Time	0.0~800.0	0.0	Sec	
07-02	Number of Auto Restart Attempts	0~10	0	-	
07-03	Reset Mode Setting	0: Enable Reset Only when Run Command is Off 1: Enable Reset when Run Command is On or Off	0	-	
07-04	Direct Running on Power Up	0: Enable Direct run on power up 1: Disable Direct run on power up	1	-	
07-05	Delay-ON Timer	1.0~300.0	1.0	Sec	
07-06	DC Injection Brake Start Frequency	0.10 ~ 10.00	1.5	Hz	
07-07	DC Injection Brake Level (Current Mode)	0.0 ~ 150.0	50.0	%	
07-08	DC Injection Brake Time	0.0 ~ 25.5	0.5	Sec	
07-09	Stopping Method	0: Deceleration to stop 1: Coast to stop	0	-	
07-10	Starting Methods	0: Normal Start 1: Speed Search	0	-	
07-11	Starting method for auto restart after fault	0: Speed Search 1: Normal start	0	-	
07-12	Power Loss Ride Through Time	0.0 ~ 2.0	0.5	Sec	
07-13	Main Circuit Low Voltage Detection Level	150.0~210.0 300.0~420.0	190.0/380.0	Vac	
07-14	Kinetic Energy Back-up Deceleration Time	0.0~25.0: KEB Deceleration Time	0.0	Sec	
07-15	DC Injection Brake Mode	0 : Current Mode 1 : Voltage Mode	1	-	*6
07-16	DC Injection Brake Level (Voltage Mode)	0.0~10.0	4.0	%	*6

Group 08: Protection Parameters					
No.	Description	Range	Factory Setting	Unit	Note
08-00	Trip Prevention Selection	xxxx0: Enable Trip Prevention During Acceleration xxxx1: Disable Trip Prevention During Acceleration xxx0x: Enable Trip Prevention During Deceleration xxx1x: Disable Trip Prevention During Deceleration xx0xx: Enable Trip Prevention in Run Mode xx1xx: Disable Trip Prevention in Run Mode x0xxx: Enable Over Voltage Prevention in Run Mode x1xxx: Disable Over Voltage Prevention in Run Mode	01000	-	*5
08-01	Trip Prevention Level During Acceleration (%)	50 ~ 200	200	% ¹	
08-02	Trip Prevention Level During Deceleration (%)	50 ~ 200	200		
08-03	Trip Prevention Level in Run Mode (%)	50 ~ 200	200		
08-04	Over Voltage Prevention Level in Run Mode	350.0~390.0/700.0~780.0	380.0/760.0	VDC	
08-05	Electronic Motor Overload Protection Operation Mode	0: Disable 1: Enable	1	-	*7
08-06	Operation After Overload Protection is Activated	0: Coast-to-Stop After Overload Protection is Activated 1: Drive Will Not Trip when Overload Protection is Activated (OL1)	0	-	
08-07	Over Heat Protection (cooling fan control)	0: Auto (Depends on temp.) 1: Operate while in RUN Mode 2: Always Run 3: Disabled	1	-	
08-08	AVR Function (Auto Voltage Regulation)	0: AVR Function is enabled	4	-	*5
		1: AVR Function is disabled			
		2: AVR Function is disabled for Stop			
		3: AVR Function is disabled for Deceleration.			
		4: AVR Function is disabled for Stop and Deceleration.			
5: When VDC>360V, AVR Function is disabled for Stop and Deceleration.					
08-09	Input Phase Loss Protection	0: Disable 1: Enable	0	-	
08-10	Output Phase Loss Protection	0: Disable	0	-	
		1: Enable			
08-11	Motor Type Selection	0: Overload protection (Standard Motor)	0	-	
		1: Overload protection (Inverter Duty Motor)			
08-12	Motor Overload Protection Curve	0: Motor Overload Protection for General loads (OL=103 %) (150% for 1 Minutes)	0	-	
		1: Motor Over load Protection for HVAC (Fan & Pump) (OL=113%) (123% for 1 Minutes).			
08-13	Over Torque Detection Control	0: Over Torque Detection Disabled	0	-	
		1: Detected After the Setting Frequency			
		2: Detected When Running			

¹ Base on the percentage of inverter rated current.

Group 08: Protection Parameters					
No.	Description	Range	Factory Setting	Unit	Note
08-14	Over torque protection action	0: Stop Output After Over Torque Detection (Free Run to Stop)	0	-	
		1: Continue Running After Over Torque Detection (Display only OL3)			
08-15	Over Torque Detection Level	30~300	160	-	
08-16	Over Torque Detection Time	0.0~25.0	0.1	-	
08-17	Fire Mode	0: Disable	0	-	*5
		1: Enable			
08-18	Ground Fault Detection	0: Disable	0		*7
		1: Enable			

Notes: Fire mode function

1. Before the firmware rev. 1.1, the fire mode is enabled when parameter 08-17 = 1
2. After the firmware 1.1, the firemode is enabled when any of parameters 03-00~03-05 is set to a value of 28
3. The keypad display will indicate FIRE
4. In fire mode the inverter will run at full speed
5. Parameter 08-18 is only displayed in the frame 3, 4 models

Group 09: Communication Parameters					
No.	Description	Range	Factory Setting	Unit	Note
09-00	Assigned Communication Station Number	1 ~ 32	1	-	*2*3
09-01	RTU/ASCII Code Selection	0:RTU Code 1:ASCII Code	0	-	*2*3
09-02	Baud Rate Setting (bps)	0:4800 1:9600 2:19200 3:38400	2	bps	*2*3
09-03	Stop Bit Selection	0:1 Stop Bit 1:2 Stop Bits	0	-	*2*3
09-04	Parity Selection	0:Without Parity 1:With Even Parity 2:With Odd Parity	0	-	*2*3
09-05	Data Format Selection	0: 8-Bits Data 1: 7-Bits Data	0	-	*2*3
09-06	Communication Time-Out Detection Time	0.0 ~ 25.5	0.0	Sec	
09-07	Communication Time Out Operation Selection	0:Deceleration to Stop (00-15: Deceleration Time 1) 1:Coast to Stop 2:Deceleration to Stop (00-17: Deceleration Time 2) 3:Continue Operating	0	-	
09-08	Comm. Fault Tolerance Count.	1 ~ 20	3		
09-09	Wait Time of Inverter Transmission	5 ~ 65	5	ms	

Group 10: PID Parameters					
No.	Description	Range	Factory Setting	Unit	Note
10-00	PID Target Value Selection (When 00-05\00-06=6 This Function is Enabled)	0: Potentiometer on Keypad 1: Analog Signal Input. (AI1) 2: Analog Signal Input. (AI2) 3: Frequency Set by Communication 4: Keypad Frequency Parameter 10-02	1	-	*1
10-01	PID Feedback Value Selection	0: Potentiometer on Keypad 1: Analog Signal Input. (AI1) 2: Analog Signal Input. (AI2) 3: Frequency Set by Communication	2	-	*1
10-02	PID Target(Keypad Input)	0.0~100.0	50.0	%	*1
10-03	PID Mode Selection	0: Disable 1: Deviation D Control. FWD Characteristic. 2: Feedback D Control FWD Characteristic. 3: Deviation D Control Reverse Characteristic. 4: Feedback D Control Reverse Characteristic.	0	-	
10-04	Feedback Gain Coefficient	0.00 ~ 10.00	1.00		*1
10-05	Proportional Gain	0.0 ~ 10.0	1.0		*1
10-06	Integral Time	0.0 ~ 100.0	10.0	Sec	*1
10-07	Derivative Time	0.00 ~ 10.00	0.00	Sec	*1
10-08	PID Offset	0: Positive 1: Negative	0	-	*1
10-09	PID Offset Adjust	0 ~ 109	0	%	*1
10-10	PID Output Lag Filter Time	0.0 ~ 2.5	0.0	Sec	*1
10-11	Feedback Loss Detection Mode	0: Disable 1: Enable - Drive Continues to Operate After Feedback Loss 2: Enable - Drive "STOPS" After Feedback Loss	0	-	
10-12	Feedback Loss Detection Level	0 ~ 100	0	%	
10-13	Feedback Loss Detection Delay Time	0.0 ~25.5	1.0	Sec	
10-14	Integration Limit Value	0 ~ 109	100	%	*1
10-15	Integral Value Resets to Zero when Feedback Signal Equals the Target Value	0: Disable 1: After 1 Second 30: After 30 Second (0~30)	0	-	
10-16	Allowable Integral value Error Margin (Units, 1 Unit = 1/8192)	0 ~ 100	0	-	
10-17	PID Sleep Frequency Level	0.00~650.00	0.00	Hz	
10-18	PID Sleep Function Delay Time	0.0 ~25.5	0.0	Sec	
10-19	PID Wake up frequency Level	0.00 ~ 650.00	0.00	Hz	
10-20	PID Wake up function Delay Time	0.0 ~ 25.5	0.0	Sec	
10-21	Max PID Feedback Setting Level	0 ~999	100	-	*1

Group 10: PID Parameters					
No.	Description	Range	Factory Setting	Unit	Note
10-22	Min PID Feedback Setting Level	0 ~999	0	-	*1

Group 11: Auxiliary Parameters					
No.	Description	Range	Factory Setting	unit	Note
11-00	Reverse Operation Control	0: Reverse Command is Enabled 1: Reverse Command is Disabled	0	-	
11-01	Carrier Frequency (kHz)	1~16	5	KHz	
11-02	Carrier Mode Selection	0: Mode0, 3Phase PWM modulation 1: Mode1, 2Phase PWM modulation 2: Mode2, 2Phase Random PWM Modulation	0	-	
11-03	Carrier Frequency Reduction by Temperature Rise	0:Disable 1:Enable	0	-	
11-04	S-Curve Acc 1	0.0 ~ 4.0	0.2	Sec	
11-05	S-Curve Acc 2	0.0 ~ 4.0	0.2	Sec	
11-06	S-Curve Dec 3	0.0 ~ 4.0	0.2	Sec	
11-07	S-Curve Dec 4	0.0 ~ 4.0	0.2	Sec	
11-08	Skip Frequency 1	0.00 ~ 650.00	0.00	Hz	*1
11-09	Skip Frequency 2	0.00 ~ 650.00	0.00	Hz	*1
11-10	Skip Frequency 3	0.00 ~ 650.00	0.00	Hz	*1
11-11	Skip Frequency Range Bandwith (\pm)	0.00 ~ 30.00	0.00	Hz	*1
11-12	Energy Saving Gain (V/F Mode)	0 ~ 100	80	%	
11-13	Regeneration Prevention Function	0:Disable	0	-	
		1:Enable			
		2:Enable (only during constant speed)			
11-14	Regeneration Prevention Voltage Level	200V:300.0~400.0	380.0	V	
		400V:600.0~800.0	760.0		
11-15	Regeneration Prevention Frequency Limit	0.00 ~ 15.00	3.00	Hz	
11-16	Regeneration Prevention Voltage Gain	0~200	100	%	
11-17	Regeneration Prevention Frequency Gain	0~200	100	%	

Group 12: Monitoring Parameters					
No.	Description	Range	Factory Setting	Unit	Note
12-00	Extended Display Mode	00000~88888 Each digit can be set from 0 to 8 as listed below.	00000	-	*1
		0: Default Display (Frequency and Parameters)			
		1: Output Current			
		2: Output Voltage			
		3: DC Voltage			
		4: Temperature			
		5: PID Feedback			
		6: Analog Signal Input. (AI1)			
7: Analog Signal Input. (AI2)					
8: Count Status					
12-01	PID Feedback Display Format	0: Integer (xxx)	0	-	*1
		1: One Decimal Place (xx.x)			
		2: Two Decimal Places (x.xx)			
12-02	PID Feedback Display Unit Setting	0: xxx--	0	-	*1
		1: xxxpb (pressure)			
		2: xxxfl (flow)			
12-03	Custom Units (Line Speed) Value	0~65535	1500/1800	RPM	*1
12-04	Custom Units (Line Speed) Display Mode	0: Drive Output Frequency is Displayed	0	-	*1
		1: Line Speed. Integer. (xxxxx)			
		2: Line Speed. One Decimal Place. (xxxx.x)			
		3: Line Speed. Two Decimal Places (xxx.xx)			
4: Line Speed. Three Decimal Places (xx.xxx)					
12-05	Inputs and Output Logic Status Display (S1~S6, RY1 and RY2)		-	-	*4
12-06	Alarm Selections for Inverter Components Life Expectancy	xxxx0: Life Alarm of Inrush Current Suppression Circuit is Invalid xxxx1: Life Alarm of Inrush Current Suppression Circuit is Valid	00000	-	*1
		xxx0x: Life Alarm of Control Circuit Capacitors is Invalid xxx1x: Life Alarm of Control Circuit Capacitors is Valid			
		xx0xx: Life Alarm of Main Circuit Capacitors is Invalid xx1xx: Life Alarm of Main Circuit Capacitors is Valid			
		Reserved			
12-07	Detect Main Circuit Capacitors	Reserved			

Group 12: Monitoring Parameters					
No.	Description	Range	Factory Setting	Unit	Note
12-08	Display of Inrush Current Suppression Circuit	0~100	100	%	
12-09	Display of Control Circuit Capacitors	0~100	100	%	
12-10	Reserved				
12-11	Output Current when Fault Appeared	----	0	A	
12-12	Output Voltage when Fault Appeared	----	0	Vac	
12-13	Output Frequency when Fault Appeared	----	0	Hz	
12-14	DC Bus Voltage when Fault Appeared	----	0	Vac	
12-15	Frequency Command when Fault Appeared	----	0	Hz	

Group 13: Maintenance Parameters					
No.	Description	Range	Factory Setting	unit	Note
13-00	Drive Horsepower Code	----	-	-	*3
13-01	Software Version	----	-	-	*3*4
13-02	Fault Log (Latest 3 Faults)	----	-	-	*3*4
13-03	Accumulated Inverter Operation Time 1	0~23	-	hour	*3
13-04	Accumulated Inverter Operation Time 2	0~65535	----	day	*3
13-05	Accumulated Inverter Operation Time Mode	0: Power On time 1: Operation time	0	-	*3
13-06	Parameter Lock	0:Enable all Functions 1:Preset Speeds from 05-01 to 05-15 Can't be Changed 2:All Functions Can't be Changed Except for Preset speeds from 05-01 to 05-15 3:Disable All Functions Except 13-06	0	-	
13-07	Parameter Lock Code	00000~65535	00000	-	
13-08	Reset Drive to Factory Settings	1150:Reset to Factory Setting(50Hz System) 1160:Reset to Factory Setting(60 Hz System) 1112:Reset PLC	00000	-	

Group 14: PLC Parameters					
No.	Description	Range	Factory Setting	unit	Note
14-00	Setting Value1 of T1	0~9999	0	-	
14-01	Setting Value1 of T1 (mode 7)	0~9999	0	-	
14-02	Setting Value1 of T2	0~9999	0	-	
14-03	Setting Value1 of T2 (mode 7)	0~9999	0	-	
14-04	Setting Value1 of T3	0~9999	0	-	
14-05	Setting Value1 of T3 (mode 7)	0~9999	0	-	
14-06	Setting Value1 of T4	0~9999	0	-	
14-07	Setting Value1 of T4 (mode 7)	0~9999	0	-	
14-08	Setting Value1 of T5	0~9999	0	-	
14-09	Setting Value1 of T5 (mode 7)	0~9999	0	-	
14-10	Setting Value1 of T6	0~9999	0	-	
14-11	Setting Value1 of T6 (mode 7)	0~9999	0	-	
14-12	Setting Value1 of T7	0~9999	0	-	
14-13	Setting Value1 of T7 (mode 7)	0~9999	0	-	
14-14	Setting Value1 of T8	0~9999	0	-	
14-15	Setting Value1 of T8 (mode 7)	0~9999	0	-	
14-16	Setting Value1 of C1	0~65535	0	-	
14-17	Setting Value1 of C2	0~65535	0	-	
14-18	Setting Value1 of C3	0~65535	0	-	
14-19	Setting Value1 of C4	0~65535	0	-	
14-20	Setting Value1 of C5	0~65535	0	-	
14-21	Setting Value1 of C6	0~65535	0	-	
14-22	Setting Value1 of C7	0~65535	0	-	
14-23	Setting Value1 of C8	0~65535	0	-	
14-24	Setting Value1 of AS1	0~65535	0	-	
14-25	Setting Value2 of AS1	0~65535	0	-	
14-26	Setting Value3 of AS1	0~65535	0	-	
14-27	Setting Value1 of AS2	0~65535	0	-	
14-28	Setting Value2 of AS2	0~65535	0	-	
14-29	Setting Value3 of AS2	0~65535	0	-	
14-30	Setting Value1 of AS3	0~65535	0	-	
14-31	Setting Value2 of AS3	0~65535	0	-	
14-32	Setting Value3 of AS3	0~65535	0	-	
14-33	Setting Value1 of AS4	0~65535	0	-	
14-34	Setting Value2 of AS4	0~65535	0	-	
14-35	Setting Value3 of AS4	0~65535	0	-	
14-36	Setting Value1 of MD1	0~65535	1	-	
14-37	Setting Value2 of MD1	0~65535	1	-	
14-38	Setting Value3 of MD1	1~65535	1	-	
14-39	Setting Value1 of MD2	0~65535	1	-	
14-40	Setting Value2 of MD2	0~65535	1	-	
14-41	Setting Value3 of MD2	1~65535	1	-	
14-42	Setting Value1 of MD3	0~65535	1	-	
14-43	Setting Value2 of MD3	0~65535	1	-	
14-44	Setting Value3 of MD3	1~65535	1	-	

14-45	Setting Value1 of MD4	0~65535	1	-	
14-46	Setting Value2 of MD4	0~65535	1		
14-47	Setting Value3 of MD4	1~65535	1	-	

Group 15: PLC Monitoring Parameters					
No.	Description	Range	Factory Setting	unit	Note
15-00	Current Value of T1	0~9999	0	-	
15-01	Current Value of T1(mode 7)	0~9999	0	-	
15-02	Current Value of T2	0~9999	0	-	
15-03	Current Value of T2(mode 7)	0~9999	0	-	
15-04	Current Value of T3	0~9999	0	-	
15-05	Current Value of T3(mode 7)	0~9999	0	-	
15-06	Current Value of T4	0~9999	0	-	
15-07	Current Value of T4(mode 7)	0~9999	0	-	
15-08	Current Value of T5	0~9999	0	-	
15-09	Current Value of T5(mode 7)	0~9999	0	-	
15-10	Current Value of T6	0~9999	0	-	
15-11	Current Value of T6(mode 7)	0~9999	0	-	
15-12	Current Value of T7	0~9999	0	-	
15-13	Current Value of T7(mode 7)	0~9999	0	-	
15-14	Current Value of T8	0~9999	0	-	
15-15	Current Value of T8(mode 7)	0~9999	0	-	
15-16	Current Value of C1	0~65535	0	-	
15-17	Current Value of C2	0~65535	0	-	
15-18	Current Value of C3	0~65535	0	-	
15-19	Current Value of C4	0~65535	0	-	
15-20	Current Value of C5	0~65535	0	-	
15-21	Current Value of C6	0~65535	0	-	
15-22	Current Value of C7	0~65535	0	-	
15-23	Current Value of C8	0~65535	0	-	
15-24	Current Value of AS1	0~65535	0	-	
15-25	Current Value of AS2	0~65535	0	-	
15-26	Current Value of AS3	0~65535	0	-	
15-27	Current Value of AS4	0~65535	0	-	
15-28	Current Value of MD1	0~65535	0	-	
15-29	Current Value of MD2	0~65535	0	-	
15-30	Current Value of MD3	0~65535	0	-	
15-31	Current Value of MD4	0~65535	0	-	
15-32	Current Value of TD	0~65535	0	μs	

5. Check motor rotation and direction

This test is to be performed solely from the inverter keypad. Apply power to the inverter after all the electrical connections have been made and protective covers have been re-attached. At this point, **DO NOT RUN THE MOTOR**, the keypad should display as shown below in Fig. 5.1 and the speed reference **5.00Hz** should be blinking at the parameter code “05-01”.

Important: Motor rotation and direction only applies to standard AC motors with a base frequency of 60Hz. For 50Hz or other frequency AC motors please set V/F pattern in group 01 before running the motor.



Fig 5.1: Keypad (Stopped)



Fig 5.2: Keypad (Running)

Next press the **RUN** key, see Fig 5.2. The motor should now be operating at low speed running in forward (clockwise) direction. Next press **STOP** key to stop the motor.

If the motor rotation is incorrect, power down the inverter.

After the power has been turned OFF, wait at least ten minutes until the charge indicator extinguishes completely before touching any wiring, circuit boards or components.

Using Safety precaution, and referring to section 3.9 exchange any two of the three output leads to the motor (U/T1, V/T2 and W/T3). After the wiring change, repeat this step and recheck motor direction.

6. Speed Reference Command Configuration

The inverter offers users several choices to set the speed reference source. The most commonly used methods are described in the next sections.

Frequency reference command is selected with parameter 00-05.

00-05: Main Frequency Command (Frequency Source)

This function sets the frequency command source.

Setting Range: 0 to 7

To set parameter 00-05:

- After power-up press the **DSP/FUN** key
- Select **00 Basic Fun**
- Press **READ/ ENTER** key
- Select parameter -05 with the **UP/DOWN ▲** and **▼** keys and press the **READ/ ENTER** key.

In the parameter list move cursor to 00-05 with the **UP/DOWN** keys and press **READ/ ENTER** key to select.

00-05	Main Frequency Command Source Selection
Range	<p>【0】 :Up/Down of Keypad 【1】 :Potentiometer on Keypad 【2】 :External AI1 Analog Signal Input 【3】 :External AI2 Analog Signal Input 【4】 :External Up/Down Frequency Control 【5】 :Communication Setting Frequency 【6】 :PID Output Frequency 【7】 :Pulse Input</p>

6.1 Reference from Keypad

Speed reference from the keypad is the default setting. Press the **READ/ ENTER** key first and use the **</RESET**, **▲** and **▼** keys to change the speed reference.



6.2 Reference from External Analog Signal (0-10V / 4-20mA)

Analog Reference: 0 – 10 V (Setting 00-05 = 2)

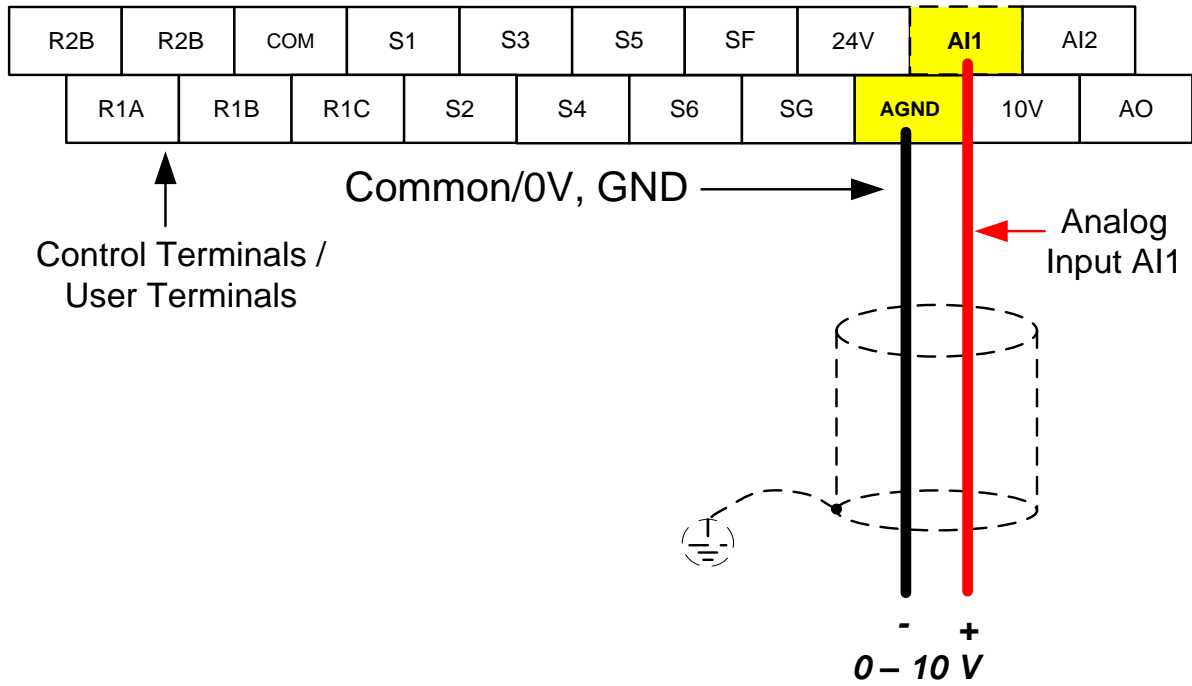

Analog Reference: Potentiometer / Speed Pot (Setting 00-05 = 2)

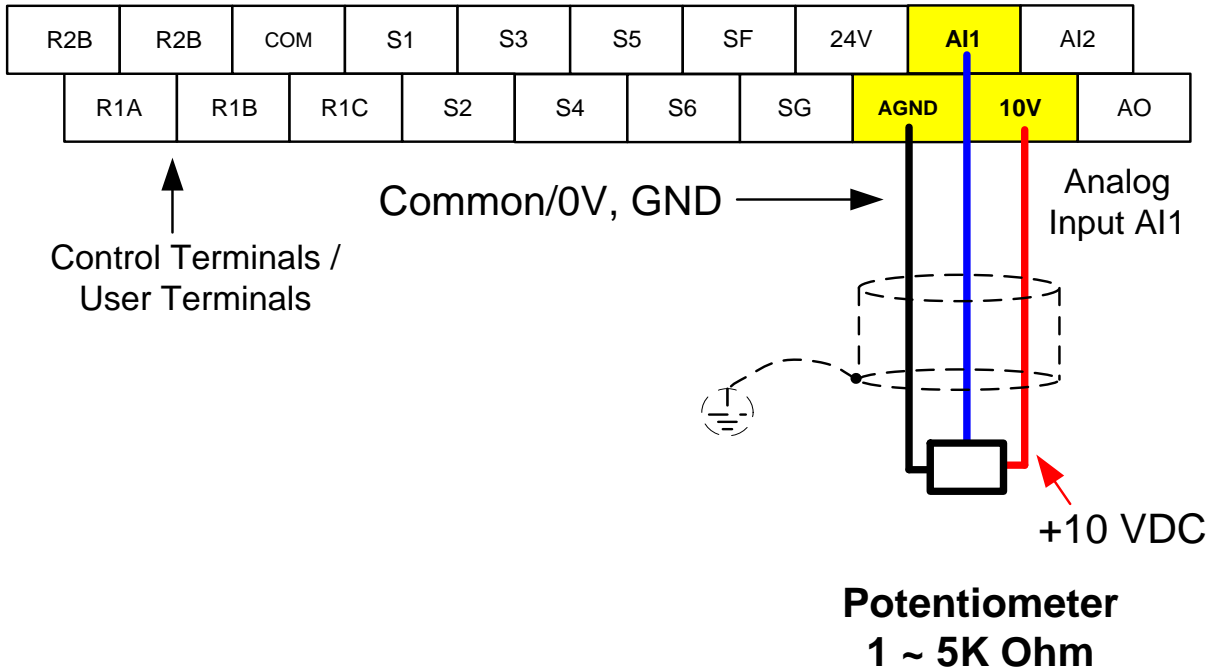

Analog Reference: 4 – 20mA (Setting 00-05 = 2)

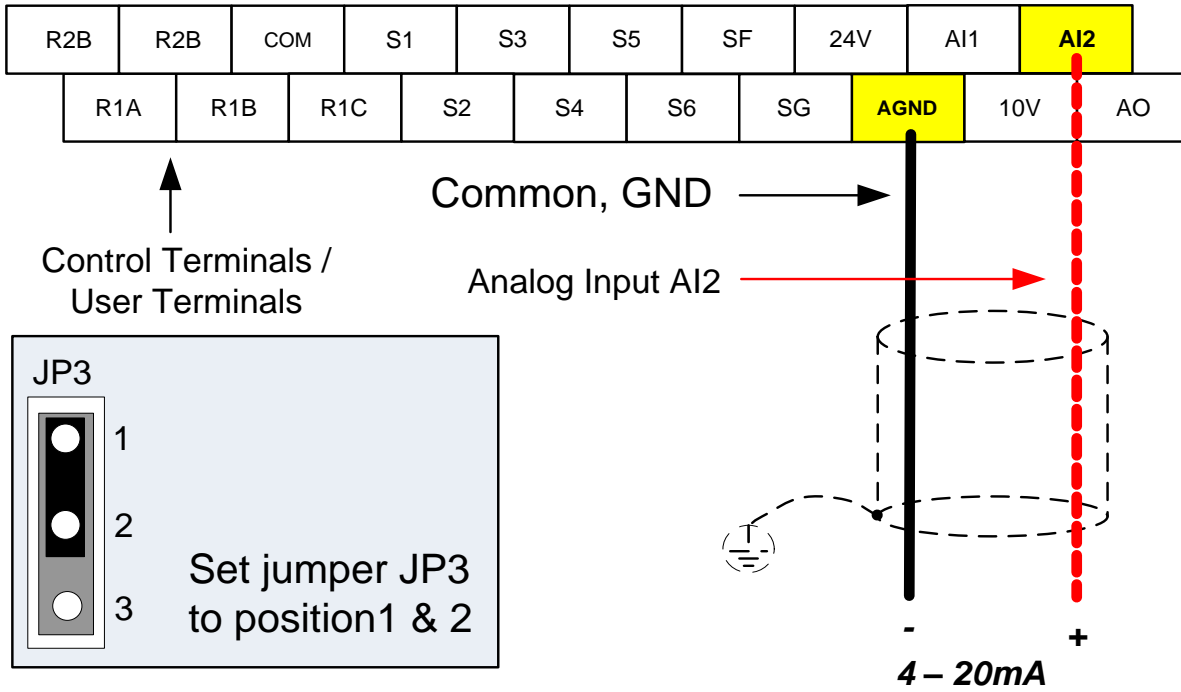

6.3 Reference from Serial Communication RS485 (00-05=5)

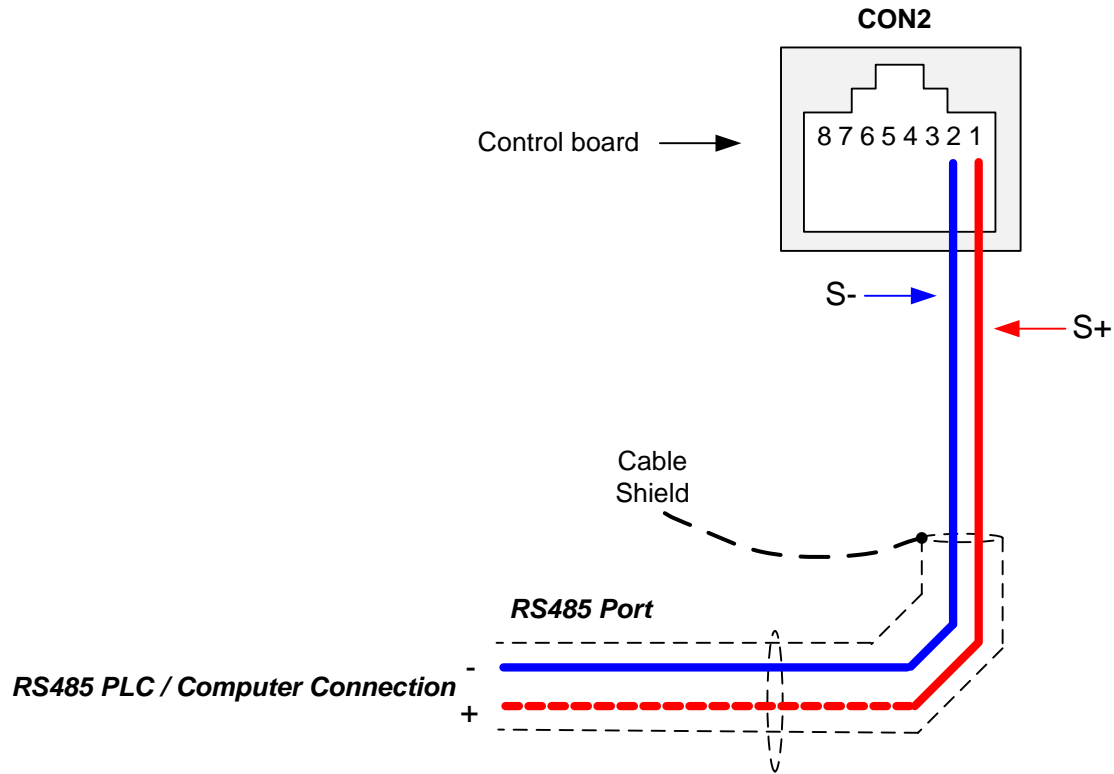

To set the speed reference for the inverter via serial communication parameter 00-05 has be set to “5” for frequency command via serial communication.

Default Communication Setting is: Address “1”, 9600 Bits/sec, 1 Start Bit, 1 Stop Bit, and No Parity

The serial communication link function uses RS485 Modbus RTU protocol and allows for:

- 1) Monitoring (data monitoring, function data check).
- 2) Frequency setting.
- 3) Operation command (FWD, REV, and other commands for digital input).
- 4) Write function data.

Frequency Reference Command Register

Inverter Frequency Reference Register: 2502 (Hexadecimal) - Bit 0 – Bit 15: 0.00 ~ 650.00 Hz

Examples:

Frequency Reference Command: 10.00 Hz (Inverter Node Address: 01)

Command String (hexadecimal): 01 06 25 02 03 E8 23 B8

To set the frequency reference to 10.00, a value of '1000' (03E8h) has to be send to the inverter.

Frequency Reference Command: 30.00 Hz (Inverter Node Address: 01)

Command String (hexadecimal): 01 06 25 02 0B B8 24 44

To set the frequency reference to 30.00, a value of '3000' (0BB8h) has to be send to the inverter.

Frequency Reference Command: 60.00 Hz (Inverter Node Address: 01)

Command String (hexadecimal): 01 06 25 02 17 70 2D 12

To set the frequency reference to 60.00, a value of '6000' (1770h) has to be send to the inverter

Note: The last 2 bytes of the command strings consist of a CRC16 checksum, please refer to section 4.5 of the instruction manual for additional information.

6.4 Reference from Pulse Input (00-05=7)

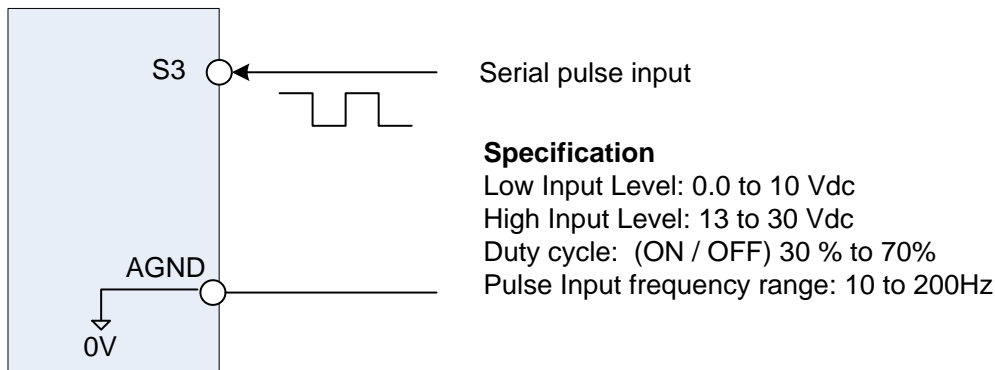

Set Pulse Input Setup as Frequency Reference

Set parameter 00-05 to 7 and 03-02 to 26 to use the pulse input terminal S3 as the frequency reference source. Next set the pulse frequency (03-27).

When 03-02=26, S3 is used for frequency measurement.

Set the following parameters to use pulse input for speed command:

00-05=7

03-02=26

03-28=1 (adjust if needed)

Example 1:

Pulse input frequency is 20Hz, frequency upper limit is 50Hz (00-12=50.00), and 03-28=1.
Inverter frequency is 20.00Hz

Example 2:

Pulse input frequency is 45Hz, frequency upper limit is 50Hz (00-12=50.00), and 03-28=1.
Inverter frequency is 45.00Hz

Example 3:

Pulse input frequency is 55Hz, frequency upper limit is 50Hz (00-12=50.00), and 03-28=1.
Inverter frequency is 50.00Hz

Example 4:

Pulse input frequency is 2000Hz, frequency upper limit is 650Hz (00-12=650.00), and 03-28=0.2.
Inverter frequency is $2000 \times 0.2 = 400.00\text{Hz}$

6.5 Change Frequency Unit from Hz to rpm

12-03	Custom Units (Line Speed) Display Mode
Range	【0~65535】 Rpm

Set motor rated RPM for the inverter to display the actual motor speed based on the output frequency.

Motor synchronous speed = $120 \times \text{Rated frequency} \div \text{Number of poles}$.

12- 04	Custom Units (Line Speed) Display Mode
Range	【0】 :Drive Output Frequency is Displayed 【1】 :Line Speed is Displayed in Integer (xxxxx) 【2】 :Line Speed is Displayed with One Decimal Place (xxxx.x) 【3】 :Line Speed is Displayed with Two Decimal Places (xxx.xx) 【4】 :Line Speed is Displayed with Three Decimal Places (xx.xxx)

Set parameter 12-04 to a value greater than 0 to display motor speed.

7. Operation Method Configuration (Run / Stop)

The inverter offers users several choices to run and stop from different sources. The most commonly used methods are described in the next sections.

Operation command is selected with parameter 00-02.

00-02: Run Command Selection

This function sets the frequency command source.

Setting Range: 0 to 3

To set parameter 00-01:

- After power-up press the **DSP/FUN** key
- Select **00 Basic Fun**
- Press **DATA/ENTER** key
- Select parameter -01 with the **UP/DOWN ▲** and **▼** keys and press the **DATA/ENTER** key.

In the parameter list move cursor to 00-01 with the **UP/DOWN** keys and press **DATA/ENTER** key to select.

00-02	Run Command Selection
Range	0: Keypad control 1: External terminal control 2: Communication control 3: PLC

7.1 Run/Stop from the Keypad (00-02=0) – Default Setting

Use the **RUN** key to run the drive in forward direction and the **FWD/REV** key to change the motor direction. (Note: to disable reverse direction set parameter 11-00 to 1)

Press **STOP** key to stop the inverter. (Note: Stop method can be set with parameter 07-09, default is **deceleration to stop**).



7.2 Run/Stop from External Switch / Contact or Pushbutton (00-02=1)

Use an external contact or switch to Run and Stop the inverter.

Set parameter 00-04 to 0 for 2-wire operation, multi-function input terminal S1 is set to run operation forward command.

00-02 Run Command Selection = 1

Permanent Switch / Contact

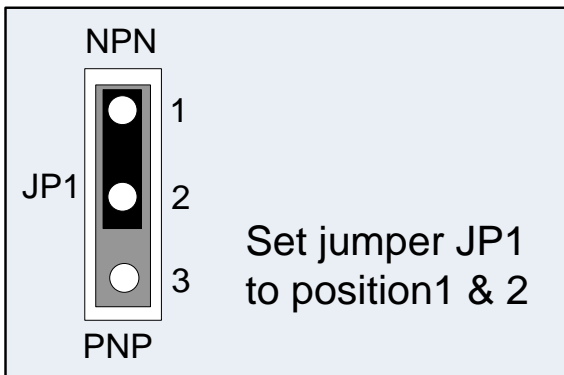
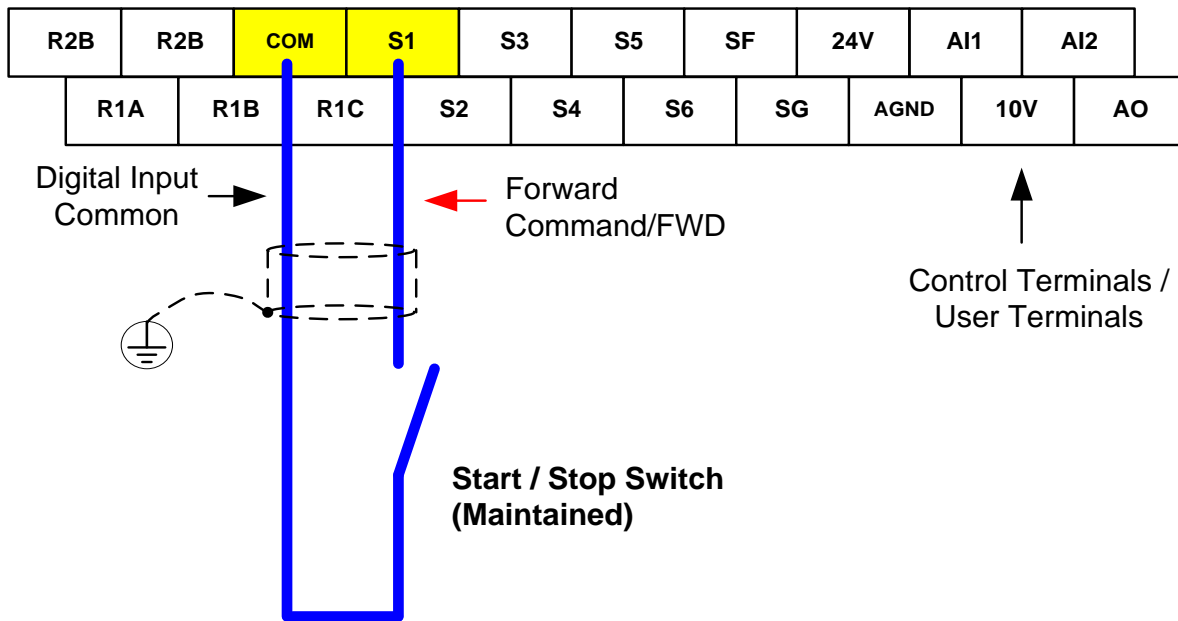

Momentary Contacts (Push Buttons)

Use push button / momentary switch to Run and Stop the inverter.

Set parameter 00-04 to 2 for 3-wire operation, multi-function input terminal S1 is set to run operation, S2 for stop operation and S3 for forward/reverse command.

00-02 Run Command Selection = 1

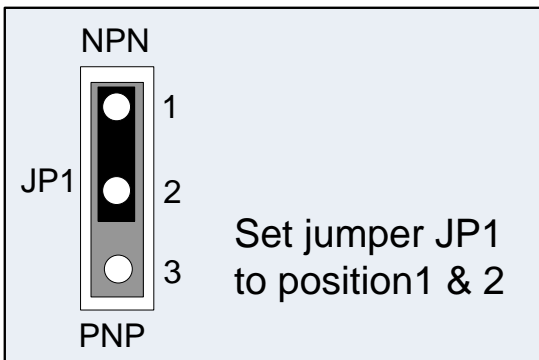
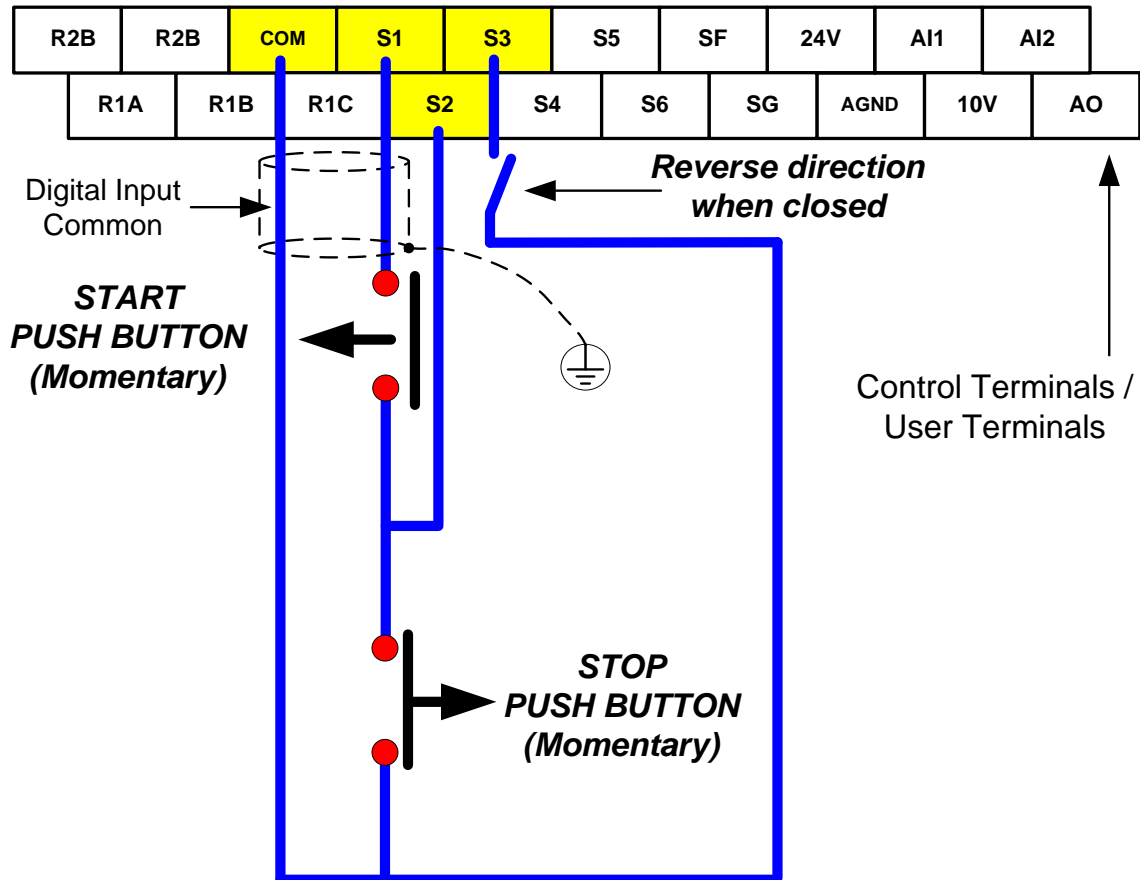

Note: Stop mode selection can be set with parameter 07-09, default is **deceleration to stop**.

7.3 Run/Stop from Serial Communication RS485 (00-02=2)

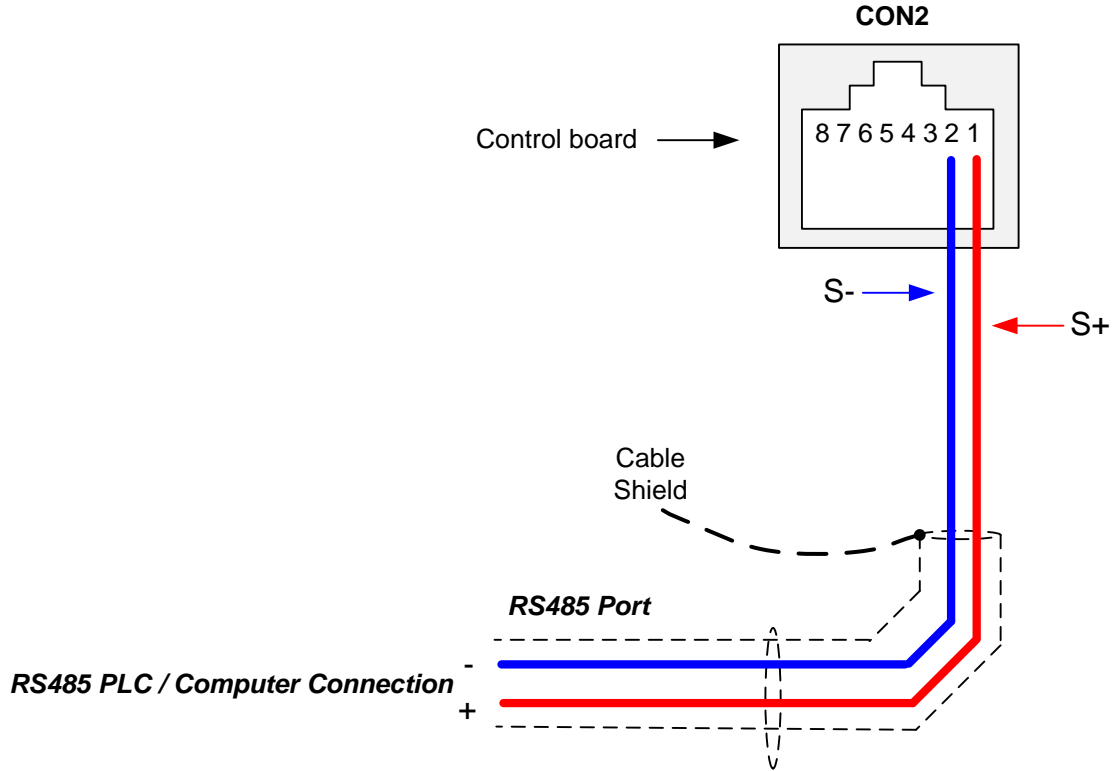

To control (Run/Stop) the inverter via serial communication parameter 00-02 has be set to a “2” for communication control.

Default Communication Setting is: Address “1”, 9600 Bits/sec, 1 Start Bit, 1 Stop Bit, and No Parity

The serial communication link function uses RS485 Modbus RTU protocol and allows for:

- 1) Monitoring (data monitoring, function data check).
- 2) Frequency setting.
- 3) Operation command (FWD, REV, and other commands for digital input).
- 4) Write function data.

Command Register

Inverter Command Register: 2501 (Hexadecimal)

Bit 0: Run Forward

Bit 1: Run Reverse

Bit 2 ~ Bit 15: Refer to the chapter XX of this manual

Examples:

Run Forward Command (Inverter Address: 01)

Command String (hexadecimal): 01 06 25 01 00 01 12 C6

Run Reverse Command (Inverter Address: 01)

Command String (hexadecimal): 01 06 25 01 00 03 93 07

Stop Command (Inverter Address: 01)

Command String (hexadecimal): 01 06 25 01 00 00 D3 06

Note: The last 2 bytes of the command strings consist of a CRC16 checksum, please refer to section 4.5 of the instruction manual for additional information.

8. Motor and Application Specific Settings

It is essential that before running the motor, the motor nameplate data matches the motor data in the inverter.

8.1 Set Motor Nameplate Data (02-01, 02-05)

02-05 Motor Rated Power

The nominal motor rated capacity is set at the factory. Please verify that the motor name plate data matches the motor rated capacity shown in parameter 02-05. The setting should only be changed when driving a motor with a different capacity.

Range: 0.1 to 37.0 kW (1HP = 0.746 kW)

To set parameter 02-05:

- After power-up press the **DSP/FUN** key
- Select **02 Motor Parameter**
- Press **READ/ ENTER** key
- Select parameter -01 with the **UP/DOWN ▲** and **▼** keys and press the **READ/ ENTER** key.

Default values vary based on the inverter model.

02-01 Motor Rated Current

The motor rated current is set at the factory based on the inverter model. Enter the motor rated current from the motor nameplate if it does not match the value shown in parameter 02-01.

Setting range: 0.2 to 100.00A

To set parameter 02-01:

- After power-up press the **DSP/FUN** key
 - Select **02 Motor Parameter**
 - Press **READ/ ENTER** key
 - Select parameter -01 with the **UP/DOWN ▲** and **▼** keys and press the **READ/ ENTER** key.
-

8.2 Acceleration and Deceleration Time (00-14, 00-15)

Acceleration and Deceleration times directly control the system dynamic response. In general, the longer the acceleration and deceleration time, the slower the system response, and the shorter time, the faster the response. An excessive amount of time can result in sluggish system performance while too short of a time may result in system instability.

The default values suggested normally result in good system performance for the majority of general purpose applications. If the values need to be adjusted, caution should be exercised, and the changes should be in small increments to avoid system instability.

00-14 Acceleration time 1

00-15 Deceleration time 1

These parameters set the acceleration and deceleration times of the output frequency from 0 to maximum frequency and from maximum frequency to 0.

To set parameter 00-14 or 00-15:

- After power-up press the **DSP/FUN** key
- Select **00 Basic Fun**
- Press **READ/ ENTER** key
- Select parameter -14 or -15 with the **UP/DOWN ▲** and **▼** keys and press the **READ/ ENTER** key.

Acceleration and deceleration times are represented by the three most significant (high order) digits. Set acceleration and deceleration times with respect to maximum frequency. The relationship between the set frequency value and acceleration/deceleration times is as follows:

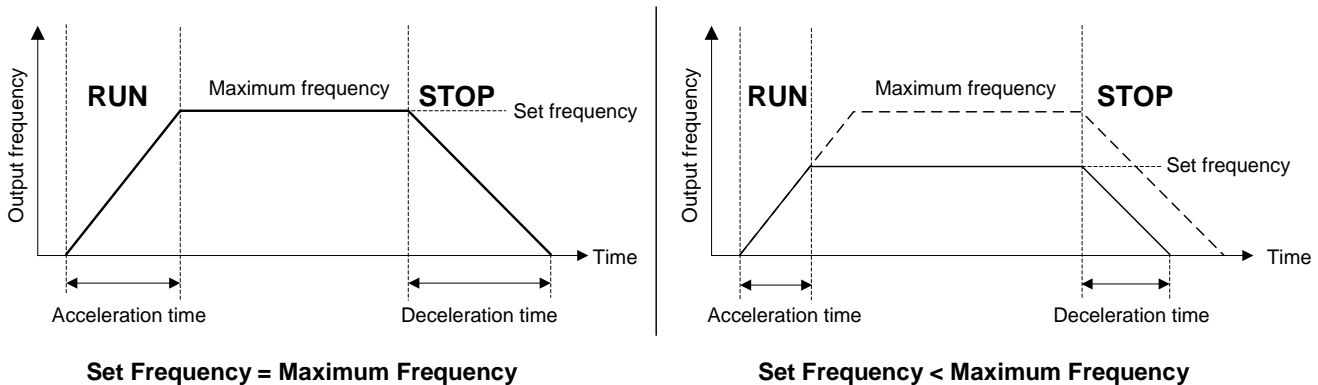

Note: If the set acceleration and deceleration times are set too low, the torque limiting function or stall prevention function can become activated if the load torque and or inertia are relatively high. This will prolong the acceleration and or deceleration times and not allow the set times to be followed. In this case the acceleration and or the deceleration times should be adjusted.

8.3 Torque Boost (V/f Curve Modification) (01-10)

This parameter sets the relationship between output frequency and output voltage. Constant torque applications have the same torque requirements at low speed as well as at high speed.

Initial Setup

For Variable Torque / Normal Duty applications set parameter 01-10 to an initial value of 0.5.

For Constant Torque / Heavy Duty applications set parameter 01-10 to an initial value of 1.0.

01-10 Torque compensation gain

This parameter sets the torque boost for motor 1.

Setting range: 0.0 to 10.0

To set parameter 01-10:

- After power-up press the **DSP/FUN** key
- Select **01 V/F Pattern**
- Press **READ/ ENTER** key
- Select parameter -10 with the **UP/DOWN ▲** and **▼** keys and press the **READ/ ENTER** key.

Increase value when:

- The wiring between the inverter and the motor very too long
- The motor size is smaller than the inverter size

Note: Gradually increase the torque compensation value and make sure the output current does not exceed inverter rated current.

Reduce value when:

- Experiencing motor vibration
- Over Current Fault
- Overload Fault

Important: Confirm that the output current at low speed does not exceed the rated output current of the inverter.



Warning: A larger than required torque compensation gain value creates over-excitation at low speeds, continued operation may cause the motor to overheat. Check the characteristics of the motor for additional information.

8.4 Rapid Stop

Deceleration time 2 is used in combination with multi-function digital input function #14 (Rapid stop). When rapid stop input is activated the inverter will decelerate to a stop using the Deceleration time 2 (00-17) and display the [E.S.] condition on the keypad.

Note: To cancel the emergency stop condition the run command has to be removed and emergency stop input deactivated.

Example: Emergency Stop Switch set for input terminal S5 (03-04 = 14).

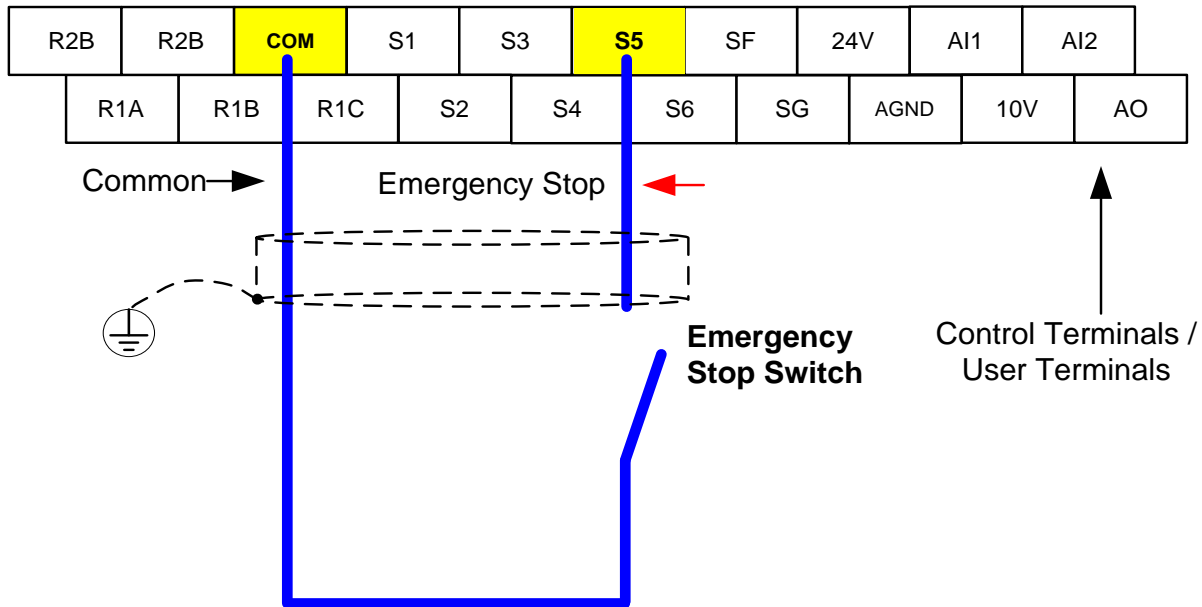

00-17	Deceleration Time 2
Range	0.1~3600.0 Sec

8.5 Forward and Reverse Jog

The jog forward command is used in combination with multi-function digital input function #6 (Jog Forward) and the jog reverse command is used in combination with multi-function digital input function #7 (Jog Reverse).

Example: Jog Forward input terminal S5 (03-04 = 06) and Jog Reverse input terminal S6 (03-05=7)

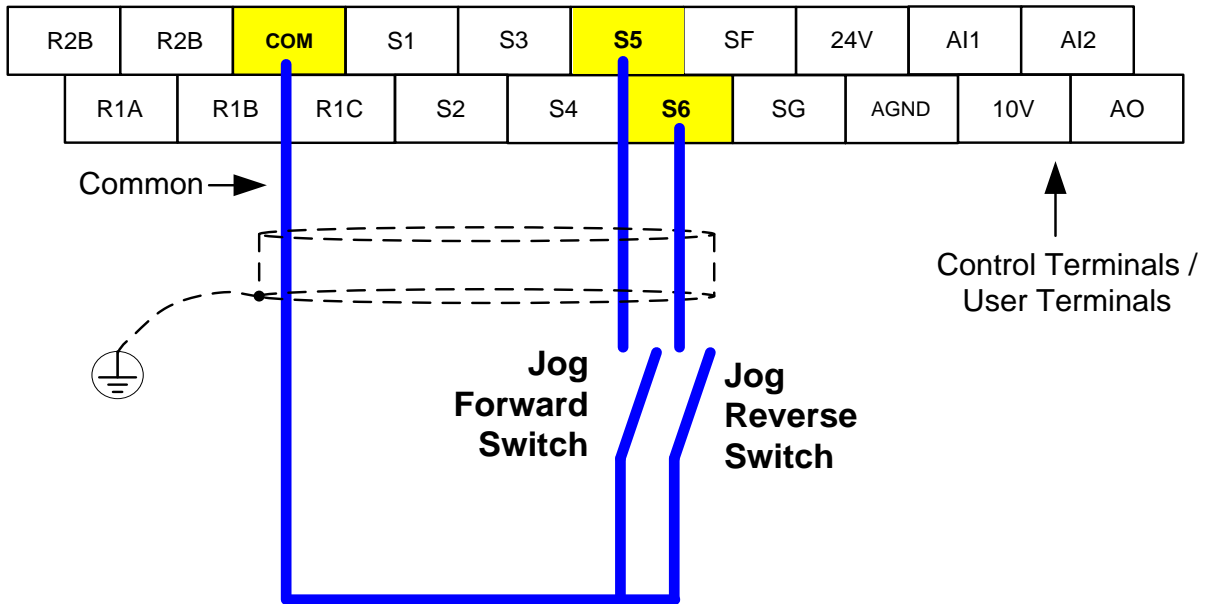

8.6 Analog Output Setup

Signal: Use parameter 04-11 to select the analog output signal for AO and parameter 04-16 to select the analog output signal for AO2.

Gain: Use parameter 04-12 to adjust the gain for AO. Adjust the gain so that the analog output (10V) matches 100% of the selected analog output signal (04-11). Use parameter 05-15 to set slope direction.

Bias: Use parameter 04-13 to adjust the bias for AO. To invert the bias use parameter 04-14. Adjust the bias so that the analog output (0V) matches 0% of the selected analog output signal (04-11).

Example: Analog Output Wiring

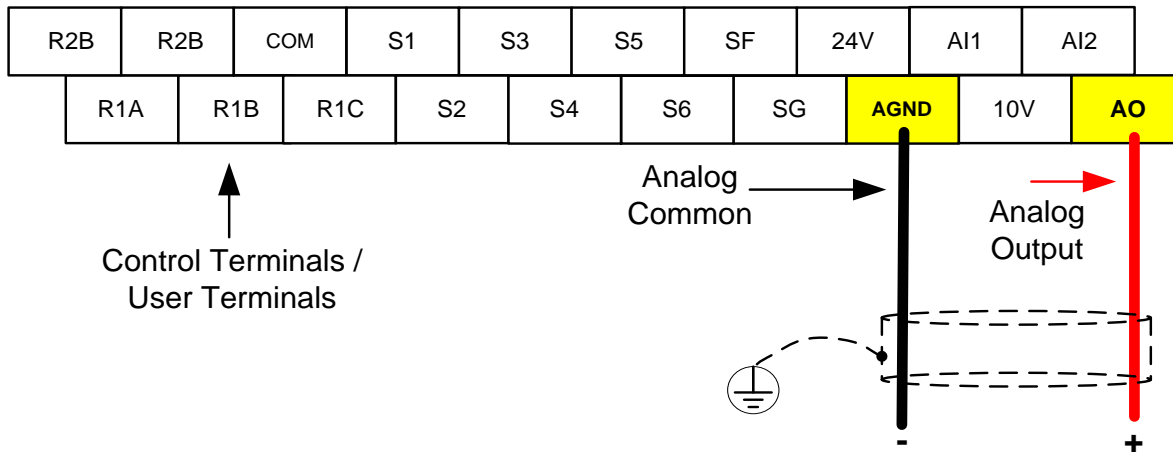

Example: Set 04-11 as required according to the table below.

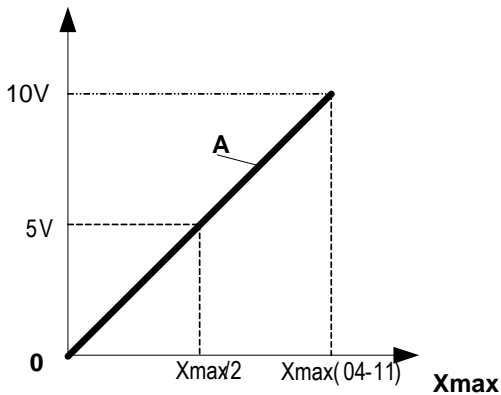

04-11	A	Xmax
【0】	Output frequency	upper frequency limit
【1】	Frequency Setting	upper frequency limit
【2】	Output voltage	Motor Rated Voltage
【3】	DC Bus Voltage	220V: 0~400V 440V: 0~800V
【4】	Output current	rated current of inverter

04-12	AO Gain
Range	【0 ~ 1000】 %
04-13	AO Bias
Range	【0 ~ 100】 %
04-14	AO Bias Selection
Range	【0】 : positive 【1】 : Negative
04-15	AO Slope
Range	【0】 : positive 【1】 : Negative

Note: The max output voltage is 10Vdc limited by the inverter hardware. Use external devices that require a maximum of 10Vdc signal.

9. Using PID Control for Constant Flow / Pressure Applications

9.1 What is PID Control?

The PID function in the inverter can be used to maintain a constant process variable such as pressure, flow, temperature by regulating the output frequency (motor speed). A feedback device (transducer) signal is used to compare the actual process variable to a specified setpoint. The difference between the set-point and feedback signal is called the error signal.

The PID control tries to minimize this error to maintain a constant process variable by regulating the output frequency (motor speed).

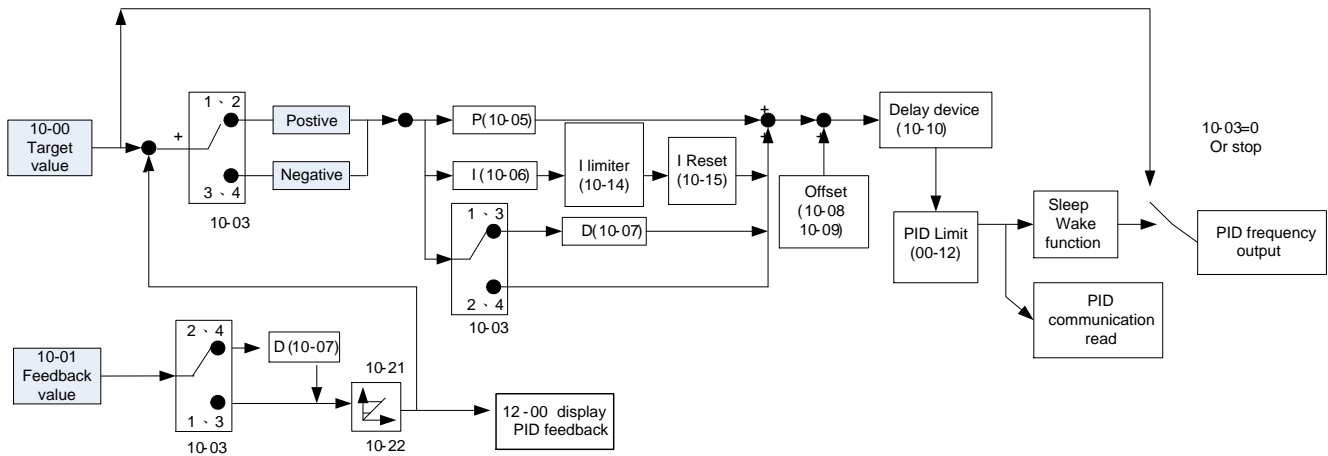

The amplitude of the error can be adjusted with the Proportional Gain parameter 10-05 and is directly related to the output of the PID controller, so the larger gain the larger the output correction.

Example 1:

Gain = 1.0

Set-Point = 80%

Feedback = 78%

Error = Set-point - Feedback = 2%

Control Error = Gain x Error = 2%

Example 2:

Gain = 2.0

Set-Point = 80%

Feedback = 78%

Error = Set-point - Feedback = 2%

Control Error = Gain x Error = 4%

Please note that an excessive gain can make the system unstable and oscillation may occur.

The response time of the system can be adjusted with the Integral Gain set by parameter 10-06. Increasing the Integral Time will make the system less responsive and decreasing the Integral Gain Time will increase response but may result in instability of the total system.

Slowing the system down too much may be unsatisfactory for the process. The end result is that these two parameters in conjunction with the acceleration (00-14) and deceleration (00-15) times are adjusted to achieve optimum performance for a particular application.

For typical fan and pump applications a Proportional Gain (10-05) of 2.0 and an Integral Time (10-06) of 5.0 sec. is recommended.

10-03 PID control mode

PID control can be enabled by setting parameter 00-05 to 6 and parameter 10-03 to a value greater than 0.

10- 03	PID Mode Selection	
Range	【0】 :PID Function disabled	
	【1】 :FWD Characteristic.	Deviation is D-controlled
	【2】 :FWD Characteristic.	Feedback is D-controlled
	【3】 :REV Characteristic.	Deviation is D-controlled
	【4】 :REV Characteristic.	Feedback is D-controlled

Commonly used PID control modes

1: Forward operation: PID operation enabled, motor speeds increases when feedback signal is smaller than set-point (most fan and pump applications)

3: Reverse operation: PID operation enabled, motor slows down when feedback signal is smaller than set-point (e.g. level control applications)

To set parameter 10-03:

- After power-up press the **MODE** key
- Select 10-03 using the arrow keys and up/down keys
- Press **</ENTER** key
- Set parameter 10-03 using the arrow keys and **</ENTER** key to save setting.

Important: To use the PID function parameter 00-05 (Main Frequency Source Selection) has to be set to 6 for PID reference.

9.2 Connect Transducer Feedback Signal (10-01)

The PID function in the inverter

Depending on the type of feedback transducer used, the inverter can be setup for either 0-10V or a 4-20mA feedback transducer.

Feedback Signal 4 – 20mA (10-01 = 2)

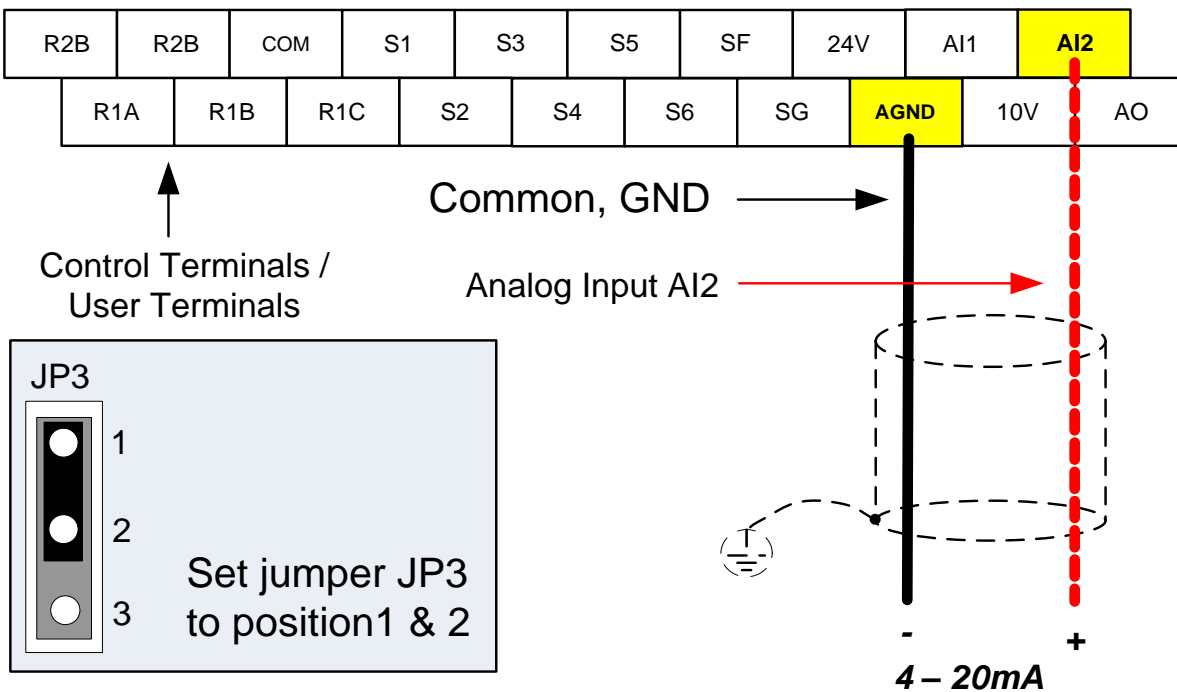

Feedback Signal 0 – 10V (10-01 = 1)

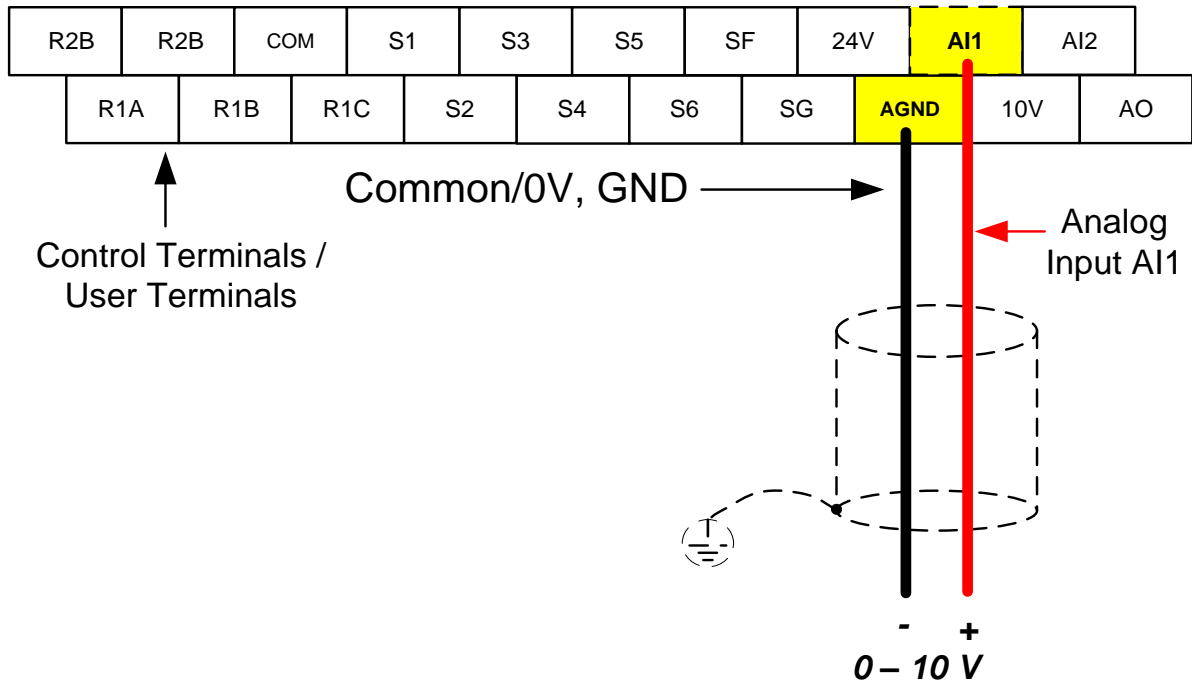

9.3 Engineering Units

PID Feedback Display Scaling

The PID feedback signal can be scaled to represent actual engineering units. Use parameter 10-21 to set the feedback signal gain for the feedback signal range maximum and parameter 10-22 to the feedback signal minimum.

Example:

Feedback signal is a pressure transducer (0-10V/0-20mA) with a range of 0 – 200 PSI
 0V/0mA = 0 PSI, 10V/20mA = 200 PSI.

Set parameter 10-21 to 200 maximum of transducer range (100%).
 Set parameter 10-22 to 0 minimum of transducer range (0%).

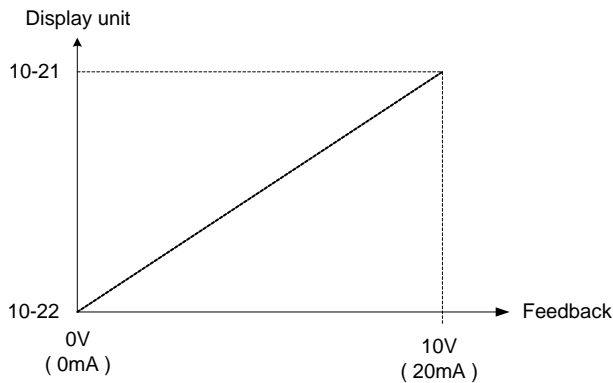

9.4 Sleep / Wakeup Function

The PID Sleep function can be used to prevent a system from running at low speeds and is frequently used in pumping application. The PID Sleep function is turned on setting parameter 10-17 to a value greater than 0. The inverter output turns off when the PID output falls below the PID sleep level (10-17) for the time specified in the PID sleep delay time parameter (10-18).

The inverter wakes up from a sleep condition when the PID output (Reference frequency) rises above the PID wake-up frequency (10-19) for the time specified in the PID wake-up delay time (10-20).

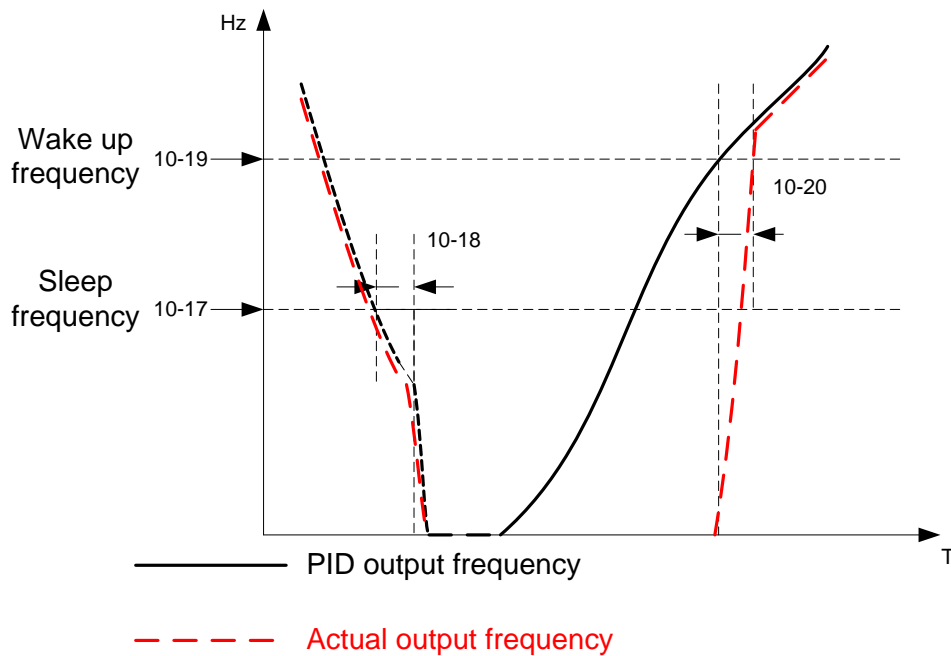
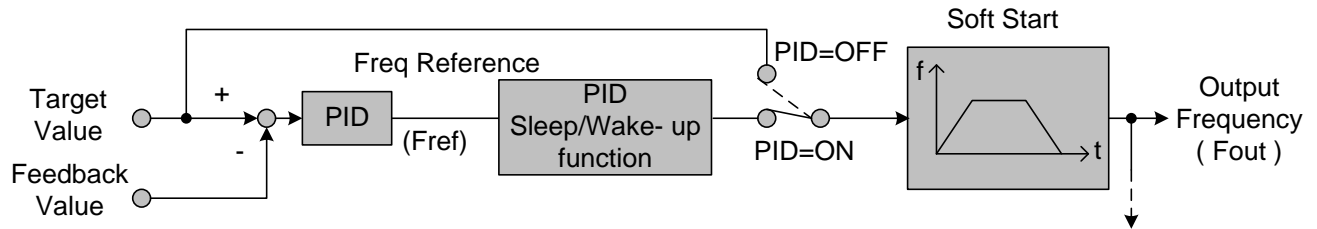

PID Sleep Function

10. Troubleshooting, Fault Diagnostics and Maintenance

10.1 General

Inverter fault detection and early warning / self-diagnosis function. When the inverter detects a fault, a fault message is displayed on the keypad.

When the inverter detects a warning / self-diagnostics error, the digital operator will display a warning or self-diagnostic code, the fault output does not energize in this case. Once the warning is removed, the system will automatically return to its original state.

10.2 Fault Detection Function

When a fault occurs, please refer to Table 10.2.1 for possible causes and take appropriate measures.

Use one of the following methods to restart:

1. Set one of multi-function digital input terminals (03-00 ~ 03-05) to 17 (Fault reset); activate input
2. Press the reset button on the keypad.
3. Power down inverter wait until keypad goes blank and power-up the inverter again.

When a fault occurs, the fault message is stored in the fault history (see group 12 parameters).

Table 5.2.1 Fault information and possible solutions

LED display	Description	Cause	Possible solutions
<p>OV Over voltage</p>	<p>DC bus voltage exceeds the OV detection level: 410Vdc: 230V class 820Vdc: 460V class</p> <p>(For 440V class, if input voltage 01-14 is set lower than 460V, the OV detection value will be decreased to 700Vdc).</p>	<ul style="list-style-type: none"> • Deceleration time set too short, resulting in regenerative energy flowing back from motor to the inverter. • The inverter input voltage is too high. • Use of power factor correction capacitors. • Excessive braking load. • Braking transistor or resistor defective. • Speed search parameters set incorrectly. 	<ul style="list-style-type: none"> • Increase deceleration time • Reduce input voltage to comply with the input voltage requirements or install an AC line reactor to lower the input voltage. • Remove the power factor correction capacitor. • Use dynamic braking unit. • Replace braking transistor or resistor. • Adjust speed search parameters.
<p>OU</p>			

LED display	Description	Cause	Possible solutions
Inverter faults that cannot be reset			
LV Under voltage	DC bus voltage is lower than the UV detection level or the pre-charge contactor is not active while the inverter is running. 190Vdc: 230V class; 380Vdc: 460V class; The detection value can be adjusted by 07-13).	<ul style="list-style-type: none"> •The input voltage is too low. •Input phase loss. •Acceleration time set too short. •Input voltage fluctuation. •Pre-charge contactor damaged. •DC bus voltage feedback signal value not incorrect. 	<ul style="list-style-type: none"> • Check the input voltage. • Check input wiring. • Increase acceleration time. • Check power source • Replace pre-charge contactor • Replace control board or complete inverter.
LU			
OH Heatsink overheat	The temperature of the heat sink is too high. Note: when OH fault occurs three times within five minutes, it is required to wait 10 minutes before resetting the fault.	<ul style="list-style-type: none"> •Ambient temperature too high. •cooling fan failed •Carrier frequency set too high. •Load too heavy. 	<ul style="list-style-type: none"> • Install fan or AC to cool surroundings. • Replace cooling fan. • Reduce carrier frequency. • Reduce load / Measure output current
OH			
OH Heatsink overheat	The temperature of the heat sink is too high. Note: when OH fault occurs three times within five minutes, it is required to wait 10 minutes before resetting the fault.	<ul style="list-style-type: none"> •Ambient temperature too high. •cooling fan failed •Carrier frequency set too high. •Load too heavy. 	<ul style="list-style-type: none"> • Install fan or AC to cool surroundings. • Replace cooling fan. • Reduce carrier frequency. • Reduce load / Measure output current
OH-C			
EEPROM Fault	EEPROM fault	•EEPROM malfunctioned	• Contact TWMC.
EPF			
CT Fault	Input voltage fault	•Abnormal input voltage, too much noise or malfunctioning control board.	• Check input voltage signal and the voltage on the control board.
CTEr			

Inverter faults that can be reset manually or via automatic restart

LED display	Description	Cause	Possible solutions
<p>OC-A over current at acceleration</p> <p style="font-size: 2em; text-align: center;">OC-A</p>	<p>The inverter output current exceeds the overcurrent level (200% of the inverter rated current).</p>	<ul style="list-style-type: none"> •Acceleration / Deceleration time is too short. •Contactor at the inverter output side. •A special motor or applicable capacity is greater than the inverter rated value. •Short circuit or ground fault. 	<ul style="list-style-type: none"> • Extend acceleration / deceleration time. • Check the motor wiring. • Disconnect motor and try running inverter.
<p>OC-C over current at fixed speed</p> <p style="font-size: 2em; text-align: center;">OC-C</p>	<p>The inverter output current exceeds the overcurrent level (200% of the inverter rated current).</p>	<ul style="list-style-type: none"> •Acceleration / Deceleration time is too short. •Contactor at the inverter output side. •A special motor or applicable capacity is greater than the inverter rated value. •Short circuit or ground fault. 	<ul style="list-style-type: none"> • Extend acceleration / deceleration time. • Check the motor wiring. • Disconnect motor and try running inverter.
<p>OC-d over current at deceleration</p> <p style="font-size: 2em; text-align: center;">OC-d</p>	<p>The inverter output current exceeds the overcurrent level (200% of the inverter rated current).</p>	<ul style="list-style-type: none"> •Acceleration / Deceleration time is too short. •Contactor at the inverter output side. •A special motor or applicable capacity is greater than the inverter rated value. •Short circuit or ground fault. 	<ul style="list-style-type: none"> • Extend acceleration / deceleration time. • Check the motor wiring. • Disconnect motor and try running inverter.
<p>OC-S over current at start</p> <p style="font-size: 2em; text-align: center;">OC-S</p>	<p>The inverter output current exceeds the overcurrent level (200% of the inverter rated current).</p>	<ul style="list-style-type: none"> •Acceleration / Deceleration time is too short. •Contactor at the inverter output side. •A special motor or applicable capacity is greater than the inverter rated value. •Short circuit or ground fault. 	<ul style="list-style-type: none"> • Extend acceleration / deceleration time. • Check the motor wiring. • Disconnect motor and try running inverter.
<p>OV-C over voltage during operation / deceleration</p> <p style="font-size: 2em; text-align: center;">OV-C</p>	<p>Excessive Voltage during operation/ deceleration</p>	<ul style="list-style-type: none"> •Deceleration time setting too short or excessive load inertia •Power voltage varies widely (fluctuates) 	<ul style="list-style-type: none"> • Set a longer deceleration time • Consider use of a brake resistor and/or brake module (in case of 400V models) • Consider use of a reactor at the power input side
<p>PF input phase loss</p> <p style="font-size: 2em; text-align: center;">PF</p>	<p>Input phase Loss</p>	<ul style="list-style-type: none"> •Abnormal fluctuations in the main circuit voltage 	<ul style="list-style-type: none"> • Check the main circuit power supply wiring. • Check the power supply voltage
<p>OC over current</p> <p style="font-size: 2em; text-align: center;">OC</p>	<p>The inverter output current exceeds the overcurrent level (200% of the inverter rated current).</p>	<ul style="list-style-type: none"> •Acceleration / Deceleration time is too short. •Contactor at the inverter output side. •A special motor or applicable capacity is greater than the inverter rated value. •Short circuit or ground fault. 	<ul style="list-style-type: none"> • Extend acceleration / deceleration time. • Check the motor wiring. • Disconnect motor and try running inverter.

LED display	Description	Cause	Possible solutions
Ud-C Under Current ud-C	Output under current detection	<ul style="list-style-type: none"> Output current < Output under current detection level. 	<ul style="list-style-type: none"> Set level according to application.
OL1 Motor overload OL1	Internal motor overload protection tripped, active when protection curve 08-05 = xxx1.	<ul style="list-style-type: none"> Voltage setting V/F mode too high, resulting in over-excitation of the motor. Motor rated current (02-01) set incorrectly. Load too heavy. 	<ul style="list-style-type: none"> Check V/f curve. Check motor rated current Check and reduce motor load, check and operation duty cycle.
OL2 Motor overload OL2	Internal motor overload protection tripped, active when protection curve 08-05 = xxx1.	<ul style="list-style-type: none"> Voltage setting V/F mode too high, resulting in over-excitation of the motor. Motor rated current (02-01) set incorrectly. Load too heavy. 	<ul style="list-style-type: none"> Check V/f curve. Check motor rated current Check and reduce motor load, check and operation duty cycle.
OL3 Over Torque OL3	Over torque	<ul style="list-style-type: none"> Motor load too big Parameter 8-15, 8-16 not set correctly 	<ul style="list-style-type: none"> Increase inverter size Adjust parameter 08-15, 08-16.
LV low voltage during operation LU-C	Voltage too low during operation	<ul style="list-style-type: none"> Power voltage too low Input power voltage fluctuates too much 	<ol style="list-style-type: none"> Improve power quality Consider adding a reactor at the power input side
OVSP Over Speed OVSP	Motor speed too high	<ul style="list-style-type: none"> Motor rotation speed greatly exceeds set speed 	<ol style="list-style-type: none"> Motor load too big Check set speed
LIFE 1 LIFE 1	Inrush current suppression circuit life expectancy alarm	<ul style="list-style-type: none"> Inrush current suppression circuit maintenance required 	<ol style="list-style-type: none"> Consult factory
LIFE 2 LIFE 2	Control Circuit Capacitor life expectancy alarm	<ul style="list-style-type: none"> Control Circuit Capacitors maintenance required 	<ol style="list-style-type: none"> Consult factory
LIFE 3 LIFE 3	Main Circuit Capacitor life expectancy alarm	<ul style="list-style-type: none"> DC-Bus Capacitors maintenance required 	<ol style="list-style-type: none"> Consult factory

Keypad Operation Error Codes

LED display	Description	Cause	Possible solutions
LOC Locked	1.Parameter already locked	<ul style="list-style-type: none"> Attempt to modify frequency parameter while 13-06>0. Attempt to reverse direction when 11-00=1 Parameter (13 - 07) enabled, set the correct password will show LOC. 	<ul style="list-style-type: none"> Adjust 13-06 Adjust 11-00
LOC	2.Motor direction locked		
	3.Parameter password (13-07) enabled		
Err1	Keypad operation error	<ul style="list-style-type: none"> Press ▲ or ▼ while 00-05/00-06>0 or running at preset speed. Attempting to modify a parameter that cannot be modified during operation (refer to the parameter list) 	<ul style="list-style-type: none"> The ▲ or ▼ is available for modifying the parameter only when 00-05/00-06=0 Modify the parameter in STOP mode.
Err1			
Err2	Parameter setting error	<ul style="list-style-type: none"> 00-13 is within the range of (11-08 ±11-11) or (11-09±11-11) or (11-10±11-11) 00-12≤00-13 Set 00-05 and 00-06 to the same value When 01-00≠7, modify parameter 01-01~01-09 	<ul style="list-style-type: none"> Modify 11-08~11-10 or 11-11 Set 00-12>00-13
Err2			
Err4	CPU performed an illegal interrupt	<ul style="list-style-type: none"> External noise 	<ul style="list-style-type: none"> Consult factory
Err4			
Err5	Modification of parameter is not available in communication	<ul style="list-style-type: none"> Control command sent during communication Attempt to modify the function 09-02~ 09-05 during communication 	<ul style="list-style-type: none"> Issue enable command before communication Set parameters 09-02~09-05 function before communication
Err5			
Err6	Communication failed	<ul style="list-style-type: none"> Wiring error Communication parameter setting error. Incorrect communication protocol 	<ul style="list-style-type: none"> Check hardware and wiring Check Functions(09-00~09- 05)
Err6			
Err7	Parameter conflict	<ul style="list-style-type: none"> Attempt to modify parameter 13-00/13-08. Voltage and current detection circuit not working properly. 	<ul style="list-style-type: none"> Consult factory if unable to reset inverter.
Err7			

Special Condition Error Codes

LED display	Fault	Description
StP0	Zero speed at stop	Occurs when preset frequency <0.1Hz
StP0		
StP1	Fail to start directly On power up.	<ul style="list-style-type: none"> • If the inverter is set for external terminal control mode (00-02/00-03=1) and direct start is disabled (07-04=1) • The inverter cannot be started and will flash STP1. • The run input is active at power-up, refer to descriptions of (07-04).
StP1		
StP2	Keypad Stop Operated when inverter in external Control mode.	<ul style="list-style-type: none"> • If the Stop key is pressed while the inverter is set to external control mode (00-02/00-03=1) then 'STP2' flashes after stop. • Release and re-activate the run contact to restart the inverter.
StP2		
E.S.	External Rapid stop	When external rapid stop input is activated the inverter will decelerate to stop and the display will flash with E.S. message.
E.S.		
b.b.	External base block	When external base block input is activated the inverter stops immediately and then the display will flash with b.b. message.
b.b.		
PdEr	PID feedback loss	PID feedback loss is detected.
PdEr		
PdEr	Auto-tuning error	<ul style="list-style-type: none"> • Motor nameplate data incorrect. • Emergency stop activated while during auto-tuning.
AdEr		
Flre	Fire Mode	<ul style="list-style-type: none"> • Software version < 1.1, fire mode is enabled when 08-17 = 1 • Software version >= 1.1, fire mode is enabled when 03-00 ~ 03-05 = 28 • Keypad display shows FlrE • In fire mode inverter will run at full speed.
FlrE		

10.3 General Troubleshooting

Status	Check	Possible Solution
Motor runs in wrong direction	Check inverter output wiring.	Wiring must match U, V, and W terminals of the motor.
	Check control terminal wiring.	Check for correct wiring.
Unable to regulate motor speed.	Check control terminal wiring.	Check for correct wiring.
	Check operation mode.	Check the Frequency Source set in parameters 00-05/00-06.
	Excessive load.	Reduce the load.
Motor running speed too high or too low	Check motor data (poles, voltage...).	Confirm the motor specifications.
	Check gear ratio.	Confirm gear ratio.
	Check maximum output frequency 00-12/01-02.	Confirm maximum output frequency
Motor speed unstable	Excessive load.	Reduce the load.
	Motor load fluctuates.	1. Minimize the variation of the load. 2. Consider increasing inverter size and the motor.
	Input voltage unstable.	1. Consider adding an AC reactor at the input power side when using single-phase power. 2. Check wiring when using three-phase power.
Motor does not run	Check input power connected and input terminals. Check if charging indicator is lit.	1. Turn input power on. 2. Cycle input power. 3. Input voltage not correct. 4. Input wiring not fastened
	Check output voltage across output terminals T1, T2, and T3.	Cycle input power.
	Check motor overload settings.	Reduce motor load.
	Are there any abnormalities in the inverter?	Check wiring and correct if necessary.
	Check forward or reverse run command.	
	Check analog frequency reference signal.	Correct analog input signal.
	Check operation mode setting 00-03.	Run inverter through via the keypad

10.4 Routine and Periodic Inspection

To ensure stable and safe inverter operation it is recommended to perform inverter maintenance at regular intervals. Use the checklist below as a guideline for inspection.

Disconnect power and wait approximately 5 minutes to make sure no voltage is present on the output terminals before carrying out any inspection or maintenance.

Items	Details	Checking period		Methods	Criteria	Remedies
		Daily	1Year			
Environment & Ground connection						
Ambient conditions on site	Confirm ambient temperature and relative humidity on site	☉		Measure with thermometer and hygrometer	Temperature: -10 – 40°C (14-120°F) Humidity: Below 95%RH	Improve the ambient or relocate the drive to a better area.
	Are there flammable materials close to the inverter?	☉		Visual check	Keep area clear	
Installation Grounding	Any unusual vibration from surrounding machine	☉		Visual, hearing check	Keep area clear	Secure screws
	Is the grounding resistance correct?		☉	Measure the resistance with a multi-meter	200Vclass: below 100Ω	Improve the grounding if needed.
Terminals & Wiring						
Connection terminals	Check for loose terminals		☉	Visual check Check with a screwdriver	Correct installation requirement	Secure terminals and remove rust
	Check for damage to base of inverter		☉			
	Check for corroded Terminals		☉			
Wiring	Check for broken wires		☉	Visual check	Correct wiring requirement	Rectify as necessary
	Check wire insulation		☉			
Input Voltage						
Input power voltage	Check input volatge	☉		Measure the voltage with a multi-meter	Voltage must conform with the spec.	Improve input voltage if necessary.

Circuit boards and components						
Printed circuit board	Check for damage to PCBs		⊙	Visual check	Correct component condition	Clean or replace the circuit board
	Check for discolored, overheated, or burned parts		⊙			
Capacitor	Check for unusual odor or leakage	⊙				
	Check for any physical damage or protrusion		⊙			
Power component	Check for any dust or debris		⊙	Measure with a multi-meter	No short circuit or faulty three-phase output	Clean components
	Check resistance between each terminals		⊙			Consult factory
Peripheral device						
Rheostat	Whether rheostat wiring or connector are damaged		⊙	Visual check	No abnormalities	Replacement rheostat
Electromagnetic Contactor	Check contacts and connections for any abnormality	⊙				
	Unusual vibration and noise	⊙		hearing check		
Reactor	Is there any abnormalities	⊙		Visual check	Replacement Reactor	
Cooling System						
Cooling fan	Unusual vibration and noise		⊙	Visual or hearing check	Correct cooling	Consult with the supplier
	Excessive dust or debris	⊙		Visual check		Clean the fan
Heat sink	Excessive dust or debris	⊙				Clean up debris or dust
Ventilation Path	Is the ventilation path blocked	⊙				Clear the path

10.5 Routine Maintenance

To ensure stable and safe inverter operation it is recommended to perform routine inverter maintenance at regular intervals. Use the checklist below as a guideline for inspection.

1. Maintenance Check List

<ul style="list-style-type: none">• Ensure that temperature and humidity where the inverter is installed falls within the specification, make sure correct ventilation is provided.
<ul style="list-style-type: none">• For replacement of a failed or damaged inverter consult factory.
<ul style="list-style-type: none">• Ensure that the installation area is free from dust and any other debris.
<ul style="list-style-type: none">• Check and ensure that the ground connections are secure and correct.
<ul style="list-style-type: none">• Terminal screws cannot be loose, tighten terminal for power input and output of the inverter with power turned off.
<ul style="list-style-type: none">• Do not perform any insulation test on the control circuit.

2. Insulation test method

Single Phase

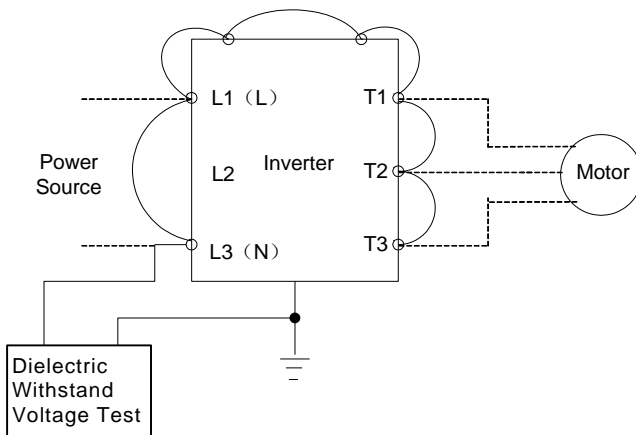

Three Phase

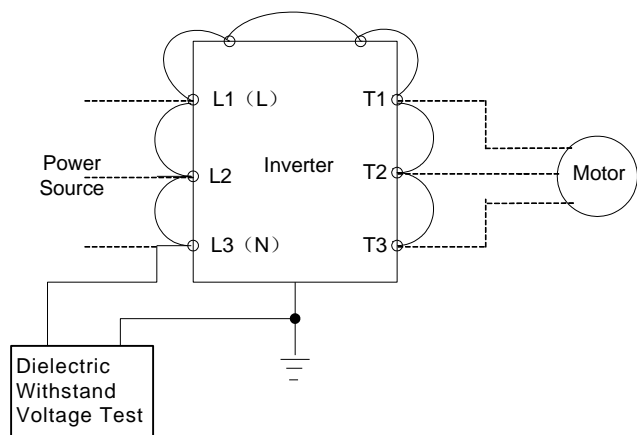

11. Commonly used parameters

00-02	Main Run Command Source Selection
00-03	Alternative Run Command Source Selection
Range	【0】 : Keypad control 【1】 : External terminal control 【2】 : Communication control 【3】 : PLC

Note: To switch the command source between the setting of main (00-02) and alternative (00-03) assign one of the DI (S1 to S6) to be the “Run Command Switch Over” (03-00~03-05=12).

00-02=0: Keypad Control

Use the keypad to start and stop the inverter and set direction with the forward / reverse key. Refer to section 4-1 for details on the keypad.

00-02=1: External Terminal Control

External terminals are used to start and stop the inverter and select motor direction. There are three different types: 2-wire and 3-wire operation and 2-wire self holding (latching) mode.

■ 2-wire operation

For 2-wire operation, set 03-00 (S1 terminal selection) to 0 and 03-01 (S2 terminal selection) to 1

Terminal S1	Terminal S2	Operation
Open	Open	Stop Inverter
Closed	Open	Run Forward
Open	Closed	Run Reverse
Closed	Closed	Stop Inverter, Display EF9 Alarm after 500ms

Figure 11.1 Wiring example of 2-wire

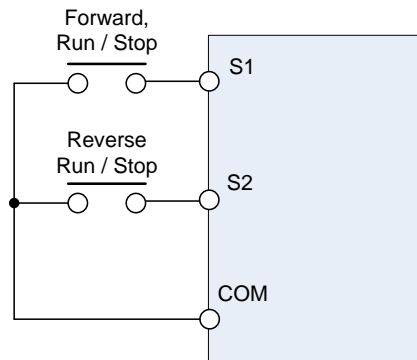

■ **3-wire operation**

Set parameter 00-04 to 3 for 3-wire program initialization, multi-function input terminal S1 is set to run operation, S2 for stop operation and S3 for forward/reverse command.

Note: Terminal S1 must be closed for a minimum of 50ms to activate operation.

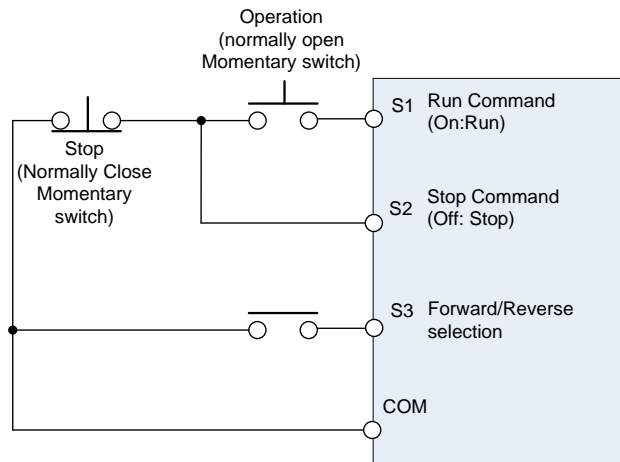

Figure 11.2 Wiring example of 3-wire

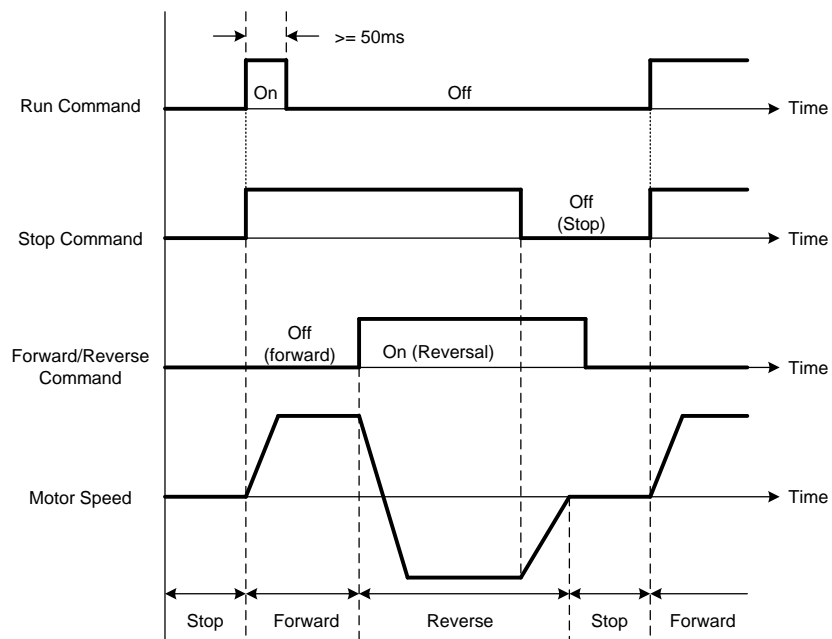

Figure 11.3 3-wire operation

00-03=2: Communication control

The inverter is controlled by the RS-485 port. Refer to parameter group 9 for communication setup.

00-03=3: PLC control

00-05	Main Frequency Command Source Selection
00-06	Alternative Frequency Source Selection
Range	【0】 :Up/Down on Keypad 【1】 :Potentiometer on Keypad 【2】 :External AI1 Analog Signal Input 【3】 :External AI2 Analog Signal Input 【4】 :External Up/Down Frequency Control 【5】 :Communication Setting Frequency 【6】 :PID Output Frequency 【7】 :Pulse Input

00-05/00-06= 0: Keypad

Use the keypad to enter the frequency reference or by setting parameter 05-01 (frequency reference 1). Note that once the frequency command is switched to alternative frequency reference and 00-06 is set to 0, the frequency can be adjusted using parameter 05-01.

00-05/00-06= 1: Potentiometer on Keypad



Use the keypad potentiometer to set frequency reference

00-05/00-06= 2, 3: External Analog Input AI1 / External Analog Input AI2

Set any of the multi-function terminals (03-00~03-05) to 13, to switch between main and alternate frequency.

Use analog reference from analog input AI1 or AI2 to set the frequency reference (as shown in Figure 4.3.4). Refer to parameter 04-00 to select the signal type.

04-00	Analog Input Signal Type Select (AI1/AI2)	AI1	AI2
		(0): 0~10V (0~20mA)	0~10V (0~20mA)
		(1): 0~10V (0~20mA)	2~10V (4~20mA) Factory Default
		(2): 2~10V (4~20mA)	0~10V (0~20mA)
		(3): 2~10V (4~20mA)	2~10V (4~20mA)

JP2/JP3		External signal type selection	0~20mA / 4~20mA Analog signal
			0~10VDC / 2~10VDC Analog signal

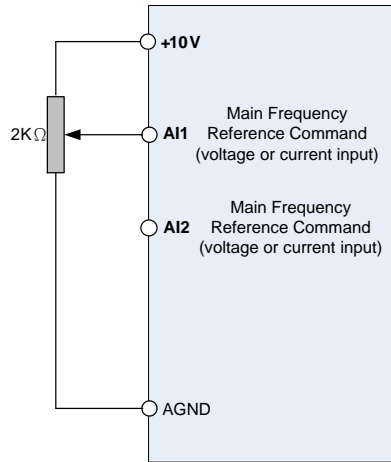

Figure 11.4 Analog input as main frequency reference command

00-05/00-06= 4: Terminal UP / DOWN

The inverter accelerates with the UP command closed and decelerates with the DOWN command closed. Please refer to parameter 03-00 ~ 03-05 for additional information.

Note: To use this function both the UP and DOWN command have to be set to any of the input terminals.

00-05/00-06= 5: Communication Control

The frequency reference command is set via the RS-485 communication port using the MODBUS RTU.

Refer to parameter group 9 for additional information.

00-05/00-06= 6: PID Output

Enables PID control, reference frequency is controlled by the PID function, refer to chapter 10 or parameter group 10 for PID setup.

00-05/00-06=7: Pulse Input

Frequency reference from an external pulse input. Can be used only with multi-function input terminal S3 (03-02 = 25 or 26). See parameter group 3 multi-function input selections 25 and 26.

00-14	Acceleration Time 1
Range	【0.1~3600.0】 Sec
00-15	Deceleration Time 1
Range	【0.1~3600.0】 Sec

Notes:

- Acceleration time is the time required to accelerate from 0 to 100% of maximum output frequency.
- Deceleration time is the time required to decelerate from 100 to 0% of maximum output frequency.
- Maximum frequency is set by parameter 01-02.
- If parameter 01-00=18, Maximum output frequency is set by parameter 01-02.
- If parameter 01-00≠18, Maximum output frequency = 50.00 or 60.00 depending on initialization mode.

Actual acceleration and deceleration time is calculated as follows:

$$\text{Actual acceleration time} = \frac{(00-14) \times (\text{set frequency} - \text{the minimum starting frequency})}{\text{Maximum output frequency}}$$

$$\text{Actual deceleration time} = \frac{(00-15) \times (\text{set frequency} - \text{the minimum starting frequency})}{\text{Maximum output frequency}}$$

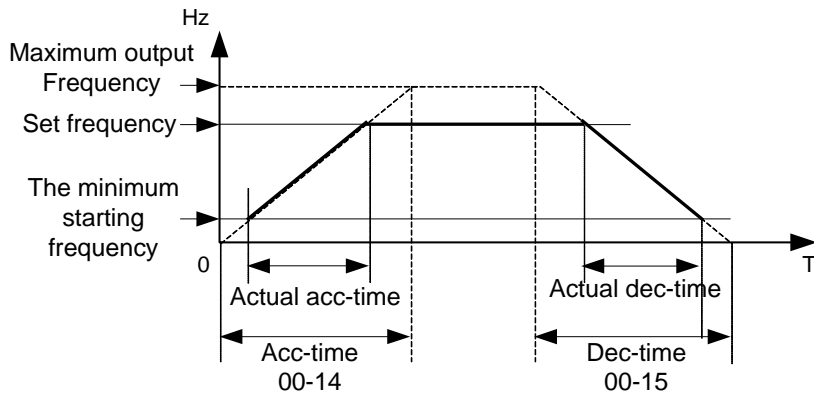

Figure 11.5 Acceleration / Deceleration Ramp

01-00	Volts/Hz Patterns (V/F)
Range	【0~18】

The V/F curve selection is enabled for V/F mode. Make sure to set the inverter input voltage parameter 01-14.

There are three ways to set V/F curve:

- (1) 01-00 = 0 to 17: choose any of the 18 predefined curves (0 to 17).
- (2) 01-00 = 18, use 01-02~01-09 and 01-12 ~ 01-13.

The default parameters (01-02 ~ 01-09 and 01-12 ~ 01-13) are the same when 01-00 is set to 18 and 01-00 is set to 0 (50Hz) or 9 (60Hz) depending on the initialization mode.

Parameters 01-02 ~ 01-13 are automatically set when any of the predefined V/F curves are selected.

This parameter will be affected to reset by the initialization parameter (13-08).

Consider the following items as the conditions for selecting a V/F pattern.

- (1) The voltage and frequency characteristic of motor.
- (2) The maximum speed of motor.

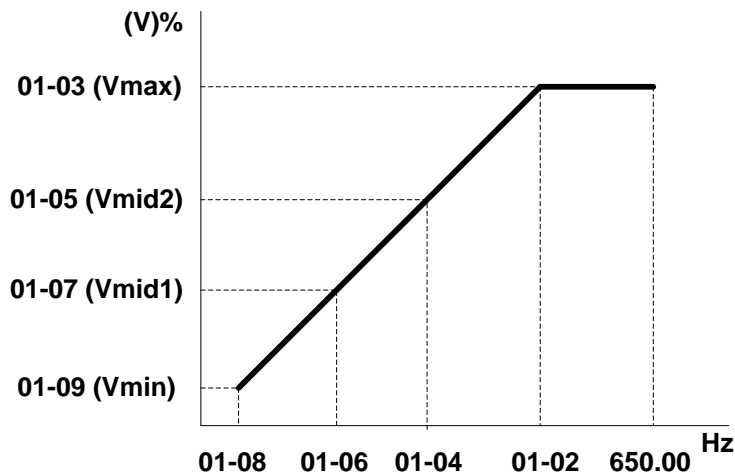

Figure 11.6 V/f Pattern

TYPE	50Hz		60Hz	
Function	01-00	V/F pattern	01-00	V/F pattern
General Use	= 【0】		= 【9】	
High start torque	= 【1】		= 【10】	
	= 【2】		= 【11】	
	= 【3】		= 【12】	
Decreasing torque	= 【4】		= 【13】	
	= 【5】		= 【14】	
Decreasing torque	= 【6】		= 【15】	
	= 【7】		= 【16】	
	= 【8】		= 【17】	

(V) 100% is the maximum output voltage. B, C point preset % settings will be as table below:

01-00	B (Xb)	C (Xc)
0 / 9	7.5%	4.5%
1 / 10	10.0%	7.0%
2	11.0%	8.5%
3	12.0%	9.5%
4	17.5%	4.0%
5	25.0%	5.0%
11	11.0%	8.0%
12	12.0%	9.0%
13	20.5%	7.0%
14	28.5%	8.0%
6 / 15	45.0%	1.0%
7 / 16	55.0%	1.0%
8 / 17	65.0%	1.0%

01-01	V/F Max Voltage
Range	【230V:170.0~264.0, 460V: 323.0~528.0】 V
01-02	Maximum Frequency
Range	【0.20 ~ 650.00】 Hz
01-03	Maximum Frequency Voltage Ratio
Range	【0.0 ~ 100.0】 %
01-04	Medium Frequency 2
Range	【0.10 ~ 650.00】 Hz
01-05	Medium Frequency Voltage Ratio 2
Range	【0.0 ~ 100.0】 %
01-06	Medium Frequency 1
Range	【0.10 ~ 650.00】 Hz
01-07	Medium Frequency Voltage Ratio 1
Range	【0.0 ~ 100.0】 %
01-08	Minimum Frequency
Range	【0.10 ~ 650.00】 Hz
01-09	Minimum Frequency Voltage Ratio
Range	【0.0 ~ 100.0】 %

Notes:

- Max output frequency is set automatically when parameter 01-00 ≠ 18.
- Maximum output frequency is limited by 01-12, frequency upper limit when 01-00 ≠ 18.
- Maximum output frequency is set by parameter 01-02 when 01-00 = 18.

03-00	Multifunction Input Term. S1
03-01	Multifunction Input Term. S2
03-02	Multifunction Input Term. S3
03-03	Multifunction Input Term. S4
03-04	Multifunction Input Term. S5
03-05	Multifunction Input Term. S6
Range	<p> 【0】 :Forward/Stop Command----- (Parameters 00-02/00-03=1& 00-04) 【1】 :Reverse/Stop Command----- (Parameters 00-02/00-03=1& 00-04) 【2】 :Speed Selection 1 【3】 :Speed Selection 2 【4】 :Speed Selection 3 【5】 :Speed Selection 4 【6】 :JOG Forward Command----- (Parameters 00-18~00-20) 【7】 :JOG Reverse Command----- (Parameters 00-18~00-20) 【8】 :Up Command----- (Parameters 00-05/00-06=4& 03-06/03-07) 【9】 :Down Command----- (Parameters 00-05/00-06=4& 03-06/03-07) 【10】 : 2nd Acc/Dec Times 【11】 : Disable Acc/Dec 【12】 : Main/ Alternative Run Source Select---- (Parameters 00-02/00-03) 【13】 : Main/ Alternative Frequency Command Select---- (Parameters 00-05/00-06) 【14】 : Rapid Stop (controlled deceleration stop) 【15】 : Base Block (Coast to stop) 【16】 : Disable PID Function ----- (Parameter Group 10) 【17】 : Reset 【18】 : Enable Auto Run Mode----- (Parameter Group 6) 【19】 : Speed Search 【20】 : Energy Saving(V/F) 【21】 : Reset PID integral value to Zero 【22】 : Counter Input 【23】 : Counter Reset 【24】 : PLC Input 【25】 : Pulse Input-Width Measure (S3) 【26】 : Pulse Input-Frequency Measure (S3) 【27】 : Enable KEB Function 【28】 : Fire mode function (Valid for software issued after rev. 1.1) </p>

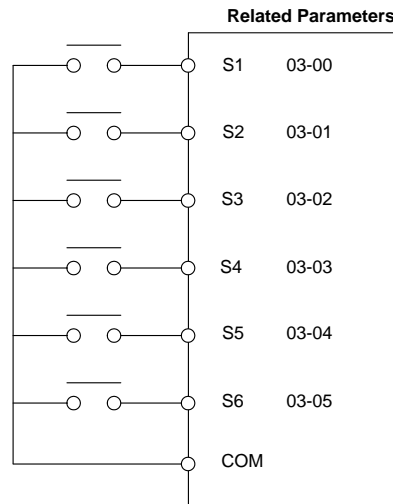

2-Wire control method

Example: FWD/STOP and REV/STOP from two inputs (S1 & S2)

Set 00-04= **【0】** ; S1:03-00= **【0】** (FWD/STOP); S2:03-01= **【1】** (REV/STOP);

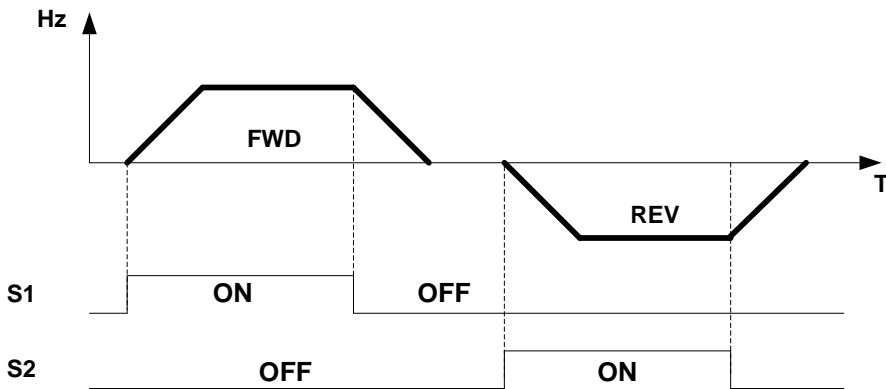
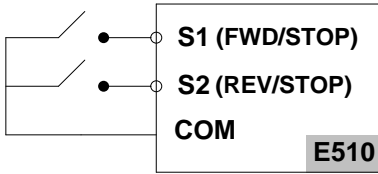

Note: If both forward and reverse commands are active the inverter treats this as a STOP command.

3-Wire control method

Example: Two separate push buttons for RUN & STOP and two position selector switch for FWD/REV

Set 00-04 = **【2】** , (3 wire control mode), to set terminals S1, S2 and S3 for 3-Wire control

When 3-Wire control mode is selected the setting for parameters 03-00, 03-01 and 03-02 are not active.

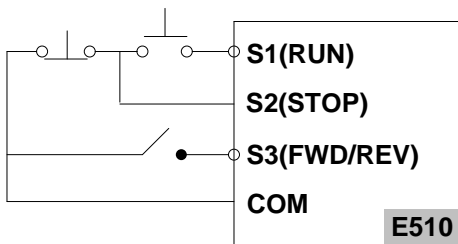

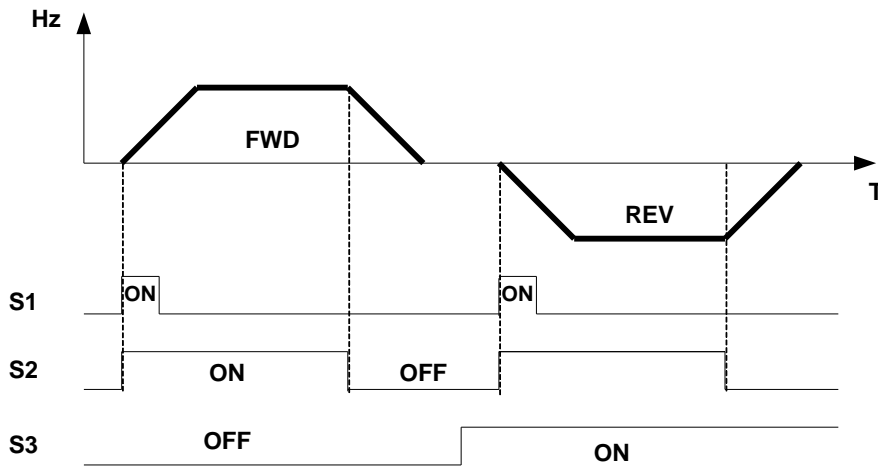

03-00~03-05 = 【5, 4, 3, 2】 Preset speed selections

Digital input S1 to S6 can be used to select between 16 different preset speeds (Preset speed 0 to 15).

Four speed selection bits are available and can be assigned to any of the digital input. The selected preset speed is based on the combination of the speed selection bits shown in the table below.

Example: Input S3 set for speed selection 1 bit, [03-02] = 2, Input S4 set for speed select 2 bit, [03-03] = 3, Input S5 set for speed select 3 bit, [03-04] = 4 and input S6 set for speed select 4 bit, [03-05] = 5.

Preset speed	Function setting and state of any of the four inputs S1 ~ S6				Preset Frequency	Acceleration time	Deceleration time
	Speed Select 4 (Sx=5)	Speed Select 3 (Sx=4)	Speed Select 2 (Sx=3)	Speed Select 1 (Sx=2)			
speed 0	OFF	OFF	OFF	OFF	05-01	05-17	05-18
speed 1	OFF	OFF	OFF	ON	05-02	05-19	05-20
speed 2	OFF	OFF	ON	OFF	05-03	05-21	05-22
speed 3	OFF	OFF	ON	ON	05-04	05-23	05-24
speed 4	OFF	ON	OFF	OFF	05-05	05-25	05-26
speed 5	OFF	ON	OFF	ON	05-06	05-27	05-28
speed 6	OFF	ON	ON	OFF	05-07	05-29	05-30
speed 7	OFF	ON	ON	ON	05-08	05-31	05-32
speed 8	ON	OFF	OFF	OFF	05-09	05-33	05-34
speed 9	ON	OFF	OFF	ON	05-10	05-35	05-36
speed 10	ON	OFF	ON	OFF	05-11	05-37	05-38
speed 11	ON	OFF	ON	ON	05-12	05-39	05-40
speed 12	ON	ON	ON	ON	05-13	05-41	05-42
speed 13	ON	ON	ON	ON	05-14	05-43	05-44
speed 14	ON	ON	ON	ON	05-15	05-45	05-46
speed 15	ON	ON	ON	ON	05-16	05-47	05-48

03-0X = 【06】 : Forward jog run command, uses jog frequency parameter 00-18.

Note:

- Jog command has a higher priority than other frequency reference commands.
- Jog command uses stop mode set in parameter 07-09 when Jog command is active > 500ms.

03-0X = 【07】 : Reverse jog run command, uses jog frequency parameter 00-18.

Note:

- Jog command has a higher priority than other frequency reference commands.
- Jog command uses stop mode set in parameter 07-09 when Jog command is active > 500ms.

Note: If Forward and Reverse Jog are active at the same time the inverter enters stop mode.

03-0X = 【08】 : UP frequency command; set parameter 00-05 Frequency command to 4 to activate. When ON frequency reference increased by value set in parameter 03-06. If the input is kept on continuously, the frequency command increases accordingly until the upper frequency limit is reached.

03-0X = 【09】 : Down frequency command; set parameter 00-05 Frequency command to 4 to activate. When ON frequency reference decreased by value set in parameter 03-06. If the input is kept on continuously, the frequency command decreases accordingly and in relation to settings for parameter 03-06 and 3-07 until zero speed is reached.

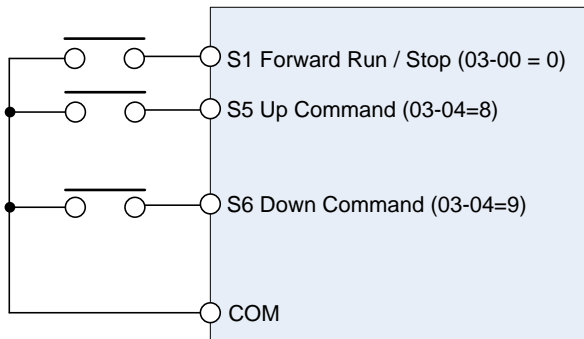

UP Command (Terminal S5)	1	0	0	1
Down Command (Terminal S6)	0	1	0	1
Operation	Accel (UP)	Decel (DWN)	Hold	Hold

03-00~03-05= 【10】 2nd Acc/Dec time

When active the acceleration and deceleration time will be set according to value set in parameter 00-16 (acceleration time 2) and 00-17 (deceleration time 2).

When not-active the acceleration and deceleration time will be set according to value set in parameter 00-14(acceleration time 1) and 00-15 (deceleration time 1).

Example: 00-12 (Frequency upper limit) =60Hz
 03-00= 0 (Terminal S1 FWD/STOP)
 00-14 (accelerating time 1) = 10 sec
 00-16 (accelerating time 2) =5 sec

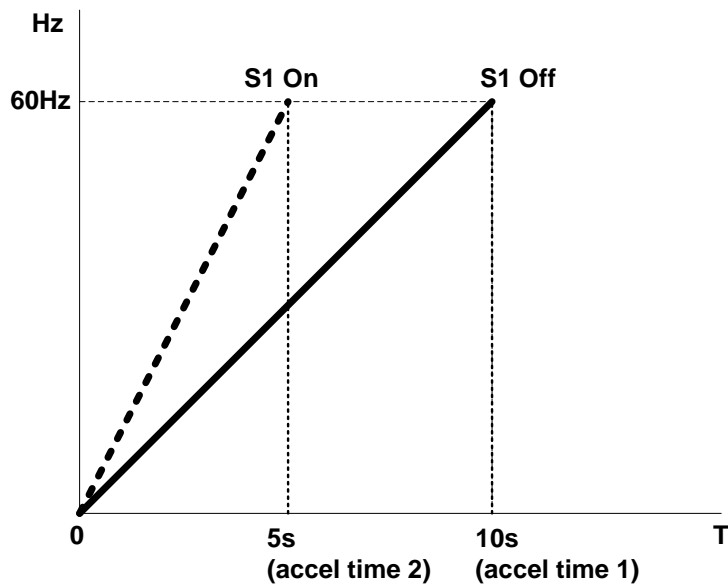

03-00-03-05= 【11】 Disable Acc/Dec function

When activated suspends the acceleration / deceleration operation and maintains the output frequency at current level.

Accel/Decel & Enable/Disable timing diagram using terminal S1 and parameter 03-00 = 11.

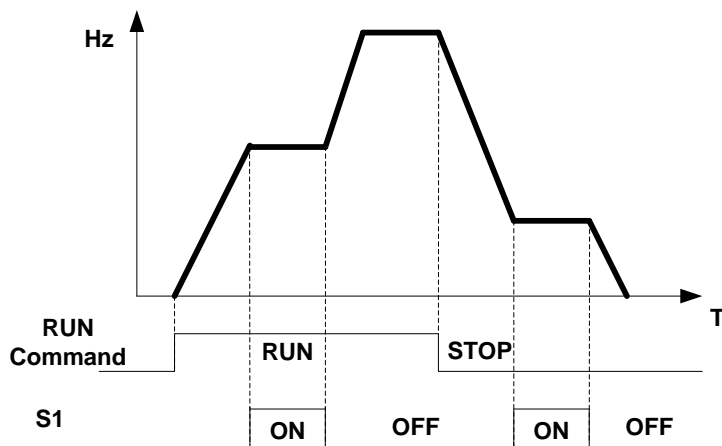

03-00-03-05= 【12】 Main / Alternative Run Source Select

When active, the run command source is set by parameter 00-03(Alternative Run source). When Input is off run command source is set by parameter 00-02 (Main run source).

03-00~03-05= 【13】 Main/ Alternative Frequency Source Select

When active the Alternative Frequency Source parameter 00-06 is used, otherwise Main Frequency Source is used parameter 00-05.

03-00~03-05= 【14】 Rapid Stop (controlled deceleration stop)

When active inverter decelerates to stop using deceleration time 2.

03-00~03-05= 【15】 Base Block (Coast to stop)

When active the inverter output is turned off.

03-00~03-05= 【16】 Disable PID Function

When active PID function is disabled.

03-00~03-05= 【17】 Reset

When active inverter resets active fault (same function as the Reset button on the keypad).

03-00~03-05= 【18】 Auto _ Run Mode

When active the programmable auto- sequencer function is enabled, Refer to description of parameter group 6.

03-00~03-05= 【19】 Speed Search Stop

When active the inverter performs a speed-search by detecting the current speed of the motor and accelerating from there to the target speed.

03-00~03-05= 【20】 Energy-saving operation

When active the inverter output voltage is gradually decreased to match the required torque demand and as a result saves energy. Only for variable torque applications such as fans and pumps that require less torque when operation speed is reached. When input is turned off the output voltage gradually increases again back to the original output voltage.

Note: Acceleration and deceleration times in energy saving operation is identical to that of speed search operation.

03-00~03-05= 【21】 Reset PID Integral value to Zero

When active resets the PID integral value zero.

03-00~03-05= 【22】 Counter Input

Input used as counter input, set related parameters 03-21 ~03-22.

Count status can be viewed by setting parameter 12-00 to 8

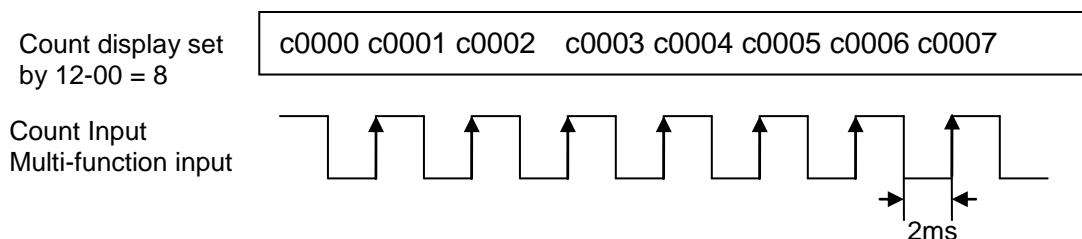

03-00~03-05= 【23】 Counter Reset

When active resets counter to 0.

03-00~03-05= 【24】 PLC Input

Input used for PLC logic.

03-02= 【25】 Pulse Input-Width Measure (Available for S3 Input only)

When 03-02=25, S3 is used for pulse width measurement.

Related parameters:

00-05=7 (Pulsed Speed Control)

03-27= 0.01~0.20 kHz (Pulse Input Frequency)

03-28=0.01~9.99

Inverter Frequency = duty cycle x (00-12) x (03-28) Hz (Limited by the Frequency Upper limit)

To adjust speed through pulse input duty cycle, set parameters as follows:

00-05=7; 03-02=25; 03-27=pulse input frequency; 03-28=1 (as per actual need)

When pulse input frequency is 200Hz, set 03-27=0.20 (must be correct). Along with the duty cycle of this 200Hz pulse input, inverter frequency is varied.

Example 1:

Pulse input frequency is 200Hz (03-27=0.20), duty cycle is 50%, frequency upper limit 50Hz (00-12=50.00), and 03-28=1. Inverter frequency is $50\% \times 50.00 \times 1 = 25.00$ Hz

Example 2:

Pulse input frequency is 100Hz (03-27=0.10), duty cycle is 30%, frequency upper limit 50Hz (00-12=50.00), and 03-28=2. Inverter frequency is $30\% \times 50.00 \times 2 = 30.00$ Hz

Example 3:

Pulse input frequency is 100Hz (03-27=0.10), duty cycle is 15%, frequency upper limit 650Hz (00-12=650.00), and 03-28=5. Inverter frequency is $15\% \times 650.00 \times 5 = 487.50$ Hz

Notes:

- In this mode, pulse input frequency range is 0.01 kHz to 10.00 kHz.
- The examples above are based on a NPN input configuration. If PNP is used, the relationship between duty cycle and inverter frequency is reversed, so a 20% duty cycle equals 80% inverter frequency

03-02= 【26】 Pulse Input-Frequency Measure (S3)

When 03-02=26, S3 is used for frequency measurement.

Related Parameters:

00-05=7 (Pulsed Speed Control)

03-02=26 (S3 is the pulse input- frequency measurement)

03-28=0.01~9.99

Inverter Frequency = $f \times (3-28)$ Hz, f: Pulse Input Frequency Hz (Limited by the Frequency Upper limit)

Set the following parameters to use pulse input for speed command:

00-05=7

03-02=26

03-28=1 (adjust if required)

03-27: Not used.

Example 1:

Pulse input frequency is 20Hz, frequency upper limit is 50Hz (00-12=50.00), and 03-28=1.

Inverter frequency is 20.00Hz

Example 2:

Pulse input frequency is 45Hz, frequency upper limit is 50Hz (00-12=50.00), and 03-28=1.

Inverter frequency is 45.00Hz

Example 3:

Pulse input frequency is 55Hz, frequency upper limit is 50Hz (00-12=50.00), and 03-28=1.

Inverter frequency is 50.00Hz

Example 4:

Pulse input frequency is 2000Hz, frequency upper limit is 650Hz (00-12=650.00), and 03-28=0.2.

Inverter frequency is $2000 \times 0.2 = 400.00$ Hz

Notes:

- In this mode, pulse input frequency range is 0.01 kHz to 200Hz.
- Pulse input can only be selected for terminal S3
- PLC common is COM terminal on TM2

03-00~03-05= 【27】 Enable KEB Function

When active enables KEB (Kinetic Energy Braking) during acceleration. Refer to the parameter description of 07-14.

03-00~03-05= 【28】 Fire Mode Function

When active inverter runs at maximum speed (parameter 00-12) ignoring any protective functions. Fire Mode function can be used for applications following a fire where it is necessary for a motor to continue running without interruption.

Example: Smoke exhaust fans used in buildings for fire evacuation.

⚠ Caution

- The correct use of this function is the responsibility of the installer of the fire safety system. TWMC bears no responsibility for direct or indirect damages or loss incurred as a result of using this function.
- Warranty is void when inverter damage is caused by using Fire Mode.

Notes:

- To enable Fire Mode function set parameter 08-17 = 1
- The fire Mode function is activated by using one of the multifunction inputs S1 to S6 to a value of 28. (Parameter 03-00~03-05).
- Fire mode can also be enabled by setting the functions of S1 to S6 via communication.

When Fire Mode is active:

- The keypad shows FlrE, and Fire Mode activation is recorded in the inverter fault log.
- The inverter will run up to the maximum frequency set in 00-12.
- The inverter will keep running unless main power is lost or the inverter breaks down.
- When Fire Mode is activated, all protection functions and alarms (e.g. ES, BB, OV, OC ...), will be ignored.
- STOP key on the keypad is disabled during Fire Mode operation.
- To reset fire mode: turn power off, remove fire mode input signal, and power-up inverter.

03-11	Multifunction Output Relay RY 1 functions. (Terminals R1C,R1B, R1A)
03-12	Multifunction Output Relay RY 2 functions. (Terminals R2B, R2A)
Range	【0】 :Run 【1】 :Fault 【2】 :Set Frequency within the preset range. -----(refer to 03-14) 【3】 :Set Frequency reached. As set by (3-13±3-14) ----- (refer to 03-13/03-14) 【4】 :Output Frequency Detection 1 (> 03-13) -----(refer to 03-13) 【5】 :Output Frequency Detection 2 (< 03-13) -----(refer to 03-13) 【6】 :Auto-restart 【7】 :Momentary AC Power Loss----- (refer to 07-00) 【8】 :Rapid Stop (Decelerate to Stop) 【9】 :Base Block Stop Mode 【10】 :Motor Overload Protection (OL1) 【11】 :Drive Overload Protection (OL2) 【12】 :Over Torque Threshold Level (OL3) 【13】 :Preset Current level Reached ----- (refer to 03-15/03-16) 【14】 :Preset Brake Frequency Reached ----- (refer to 03-17/03-18) 【15】 :PID Feedback Signal Loss 【16】 :Single pre-set count (3-22) 【17】 :Dual pre-set count (3-22~23) 【18】 :PLC status indicator (00-02) 【19】 :PLC control 【20】 :Zero Speed
03-13	Frequency Reached Level
Range	【0.00~650.00】 Hz
03-14	Frequency Reached Detection Range (±)
Range	【0.00~30.00】 Hz

Output relay RY function descriptions:

03-11/03-12 = **【0】** : Run

Output is active when run command is ON or output frequency is greater than 0

03-11/03-12 = **【1】** : Fault

Output is active during fault condition.

03-11/03-12 = **【2】** Set Frequency within the preset range

Output is active when the output frequency falls within the frequency reference minus the frequency detection width (03-14).

When Output Freq. = Preset Freq. Reached Setting (03-13) - Preset Freq.
Reached Detection Range (03-14), Relay Output will be ON

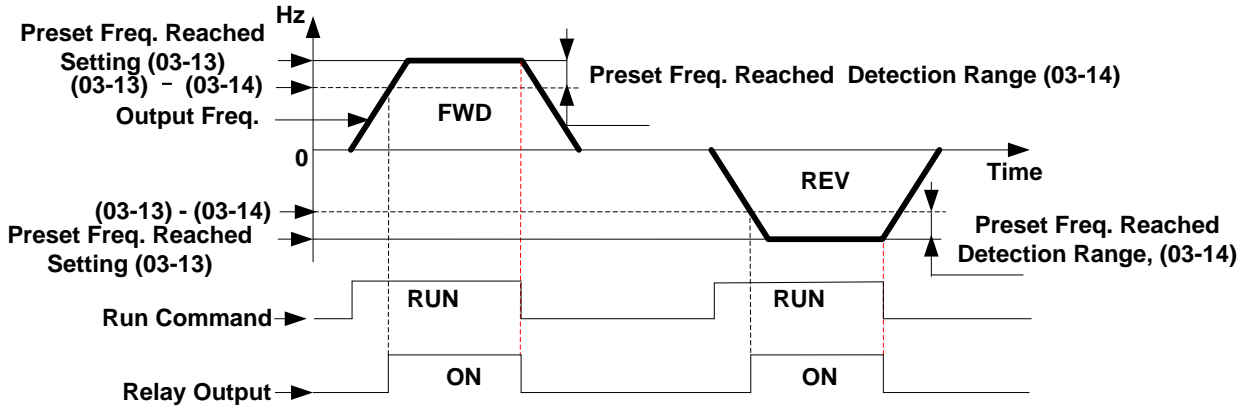

Example: Sets 03-13=30 and 03-14=5, Relay is ON when output frequency is $\geq 25\text{Hz}$ and $\leq 30\text{Hz}$.

03-11=【3】 : Set Frequency reached

Output is active when the output frequency falls within the frequency detection width (03-14) of the set frequency detection level (03-13).

When, Freq. Detection Range Lower Limit < Setting Freq. < Freq. Detection Range Upper Limit
and Detection Range Lower Limit < Output Freq. < Freq. Detection Range Upper Limit
Relay output is ON (Allowable tolerance ± 0.01)

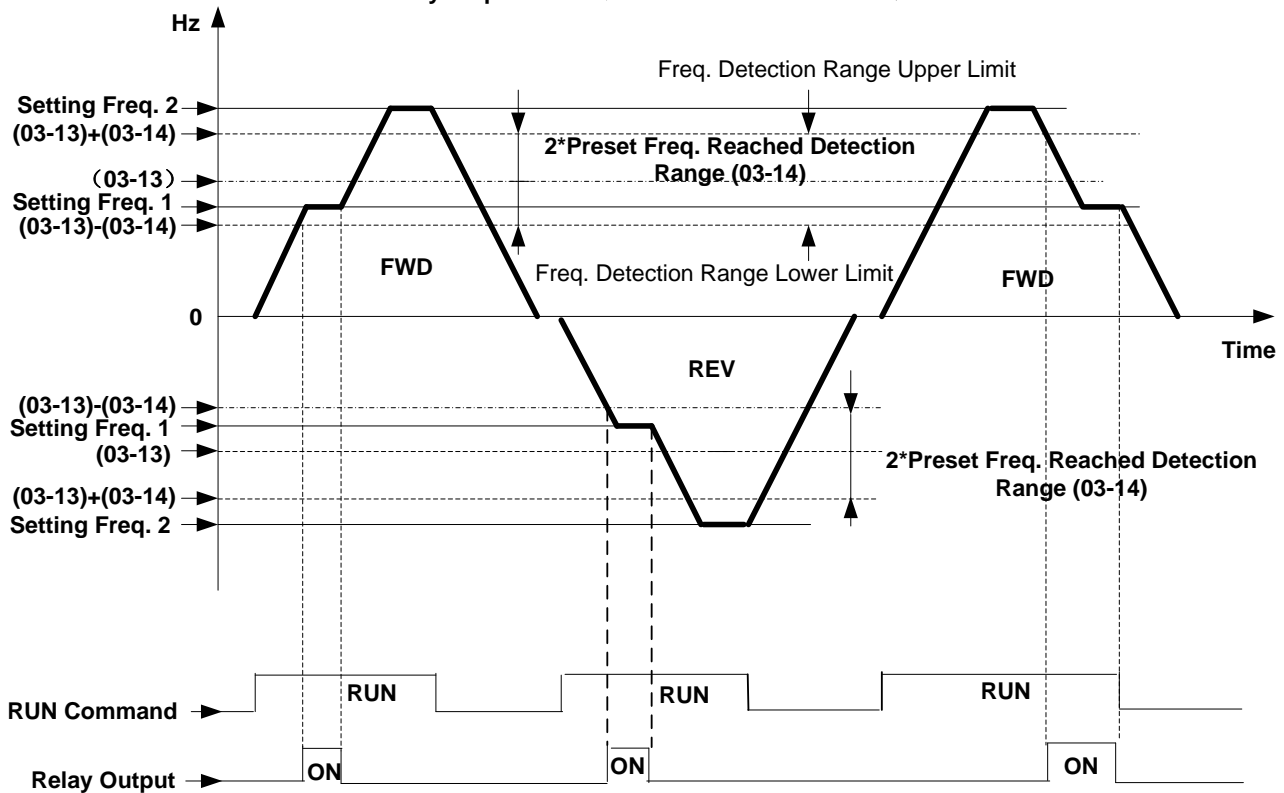

03-11=【4】 : Output Frequency Detection 1

Output is active when the output frequency rises above the frequency detection level (03-13) and deactivates when the output frequency falls below frequency detection level (03-13).

When Output Frequency > Preset Frequency Reached Setting (03-13),
Relay output is ON

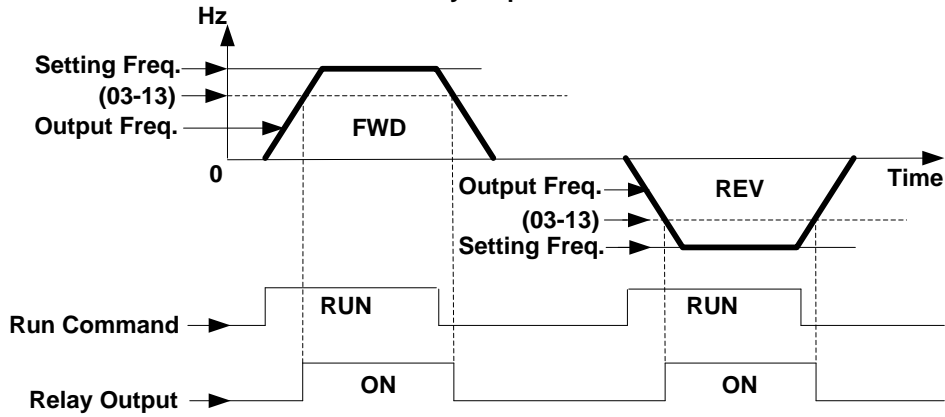

03-11=【5】 : Output Frequency Detection 2

Output is active when the output frequency is below the frequency detection level (03-13) and turns off when the output frequency falls below frequency detection level (03-13).

When Output Freq.<Preset Freq. Reached Setting (03-13),
Relay output will be ON

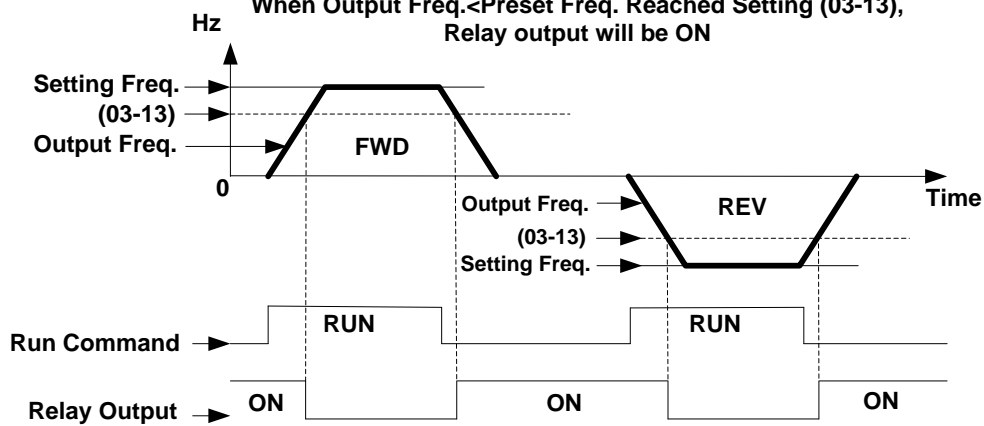

03-13	Frequency Reached Level
Range	【0.00~650.00】 Hz
03-14	Frequency Reached Detection Range (±)
Range	【0.00~30.00】 Hz

03-11/03-12= **【20】** : Zero Speed

Off	Output Frequency => Minimum Frequency (01-08, Fmin)
On	Output Frequency < Minimum Frequency (01-08, Fmin)

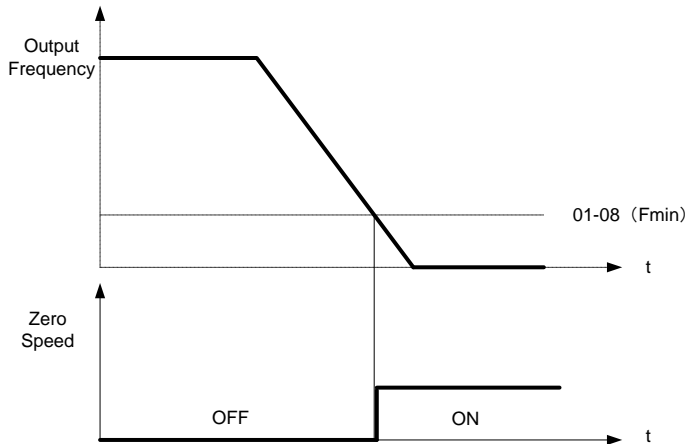

04-00	Analog Voltage & Current Input Selections AI1/AI2	
Range	AI1	AI2
	【0】 : 0~10V (0~20mA)	0~10V (0~20mA)
	【1】 : 0~10V (0~20mA)	2~10V (4~20mA)
	【2】 : 2~10V (4~20mA)	0~10V (0~20mA)
	【3】 : 2~10V (4~20mA)	2~10V (4~20mA)

- Use JP2/JP3 to select analog signal type (voltage or current input).
- Parameter 04-00 must be set according to JP2 / JP3 setting.

Analog input scaling:

■ **Current Input Mode**

$$AI (0\sim 20mA) : F (Hz) = \frac{I (mA)}{20(mA)} \times (00 - 12)$$

$$AI (4\sim 20mA) : F (Hz) = \frac{I - 4(mA)}{20 - 4(mA)} \times (00 - 12), I \geq 4$$

■ **Voltage Input Mode**

$$AI (0\sim 10V) : F (Hz) = \frac{V (v)}{10(v)} \times (00 - 12)$$

$$AI (2\sim 10V) : F (Hz) = \frac{V - 2(v)}{10 - 2(v)} \times (00 - 12), V \geq 2$$

04-01	AI1 Signal Verification Scan Rate
Range	【1~200】 2msec
04-02	AI1 Gain
Range	【0 ~ 1000】 %
04-03	AI1 Bias
Range	【0~ 100】 %
04-04	AI1 Bias Selection
Range	【0】 : Positive 【1】 : Negative
04-05	AI1 Slope
Range	【0】 : Positive 【1】 : Negative
04-06	AI2 signal verification Scan Rate
Range	【1~200】 2msec
04-07	AI2 Gain
Range	【0 ~ 1000】 %
04-08	AI2 Bias
Range	【0 ~ 100】 %
04-09	AI2 Bias Selection
Range	【0】 : Positive 【1】 : Negative
04-10	AI2 Slope
Range	【0】 : Positive 【1】 : Negative

Set 04-01 and 04-06 for analog signal verification.

All analog inputs (AI1, AI2) have a 1st order programmable input filter that can be adjusted when noise is present on each of the incoming analog signal to prevent erratic drive control. Inverter reads the average values of A/D signal once per (04-01/04-06 x 2ms).

Note: Increasing the filter time causes the drive operation to become more stable but less responsive to change to the analog input.

AI1 Analog Voltage input scaling examples by adjusting Gain, Bias & Slope parameters (04-02~04-05)

(1) **Positive Bias type** (04-04= 0), Bias (04-03) and Slope (04-05).

Figure1:

	04-02	04-03	04-04	04-05
A	100%	50%	0	0
B	100%	0%	0	0

Figure2:

	04-02	04-03	04-04	04-05
C	100%	50%	0	1
D	100%	0%	0	1

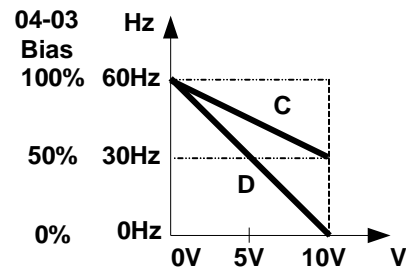
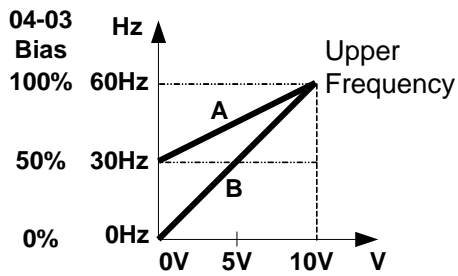

(2) **Negative Bias type** (04-04= 1), Bias (04-03) and Slope (04-05).

Figure3:

	04-02	04-03	04-04	04-05
E	100%	20%	1	0

Figure4:

	04-02	04-03	04-04	04-05
F	100%	50%	1	1

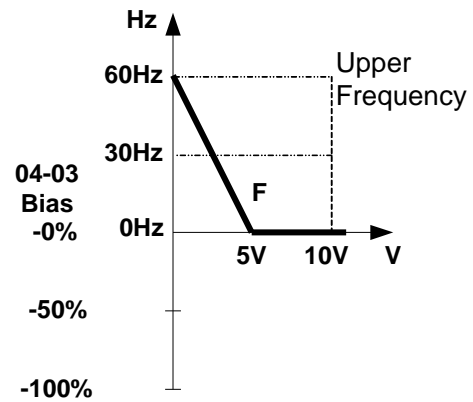
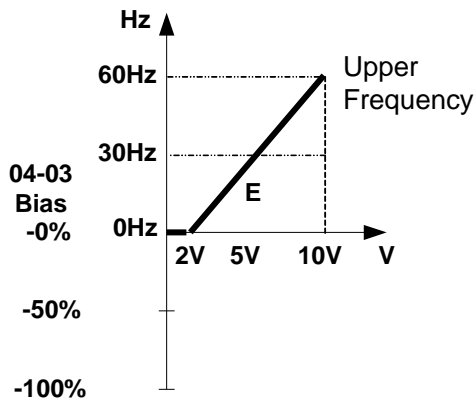

(3) **Offset bias set to 0% (04-03) and effect of modifying Analog Gain (04-02), Bias type (04-04) and slope type (04-05) are shown in shown Fig 5&6.**

Figure5:

	04-02	04-03	04-04	04-05
A'	50%	0%	0/1	0
B'	200%	0%	0/1	0

Figure6:

	04-02	04-03	04-04	04-05
C'	50%	0%	0/1	1
D'	200%	0%	0/1	1

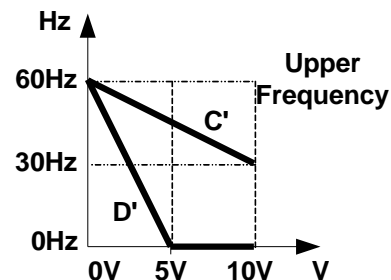
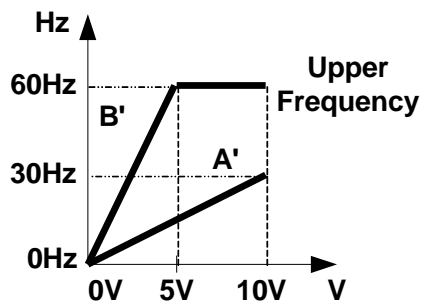

(4) Various other examples of analog input scaling and modification are shown in following figures 7,8,9 & 10.

Figure7:

	04-02	04-03	04-04	04-05
a	50%	50%	0	0
b	200%	50%	0	0

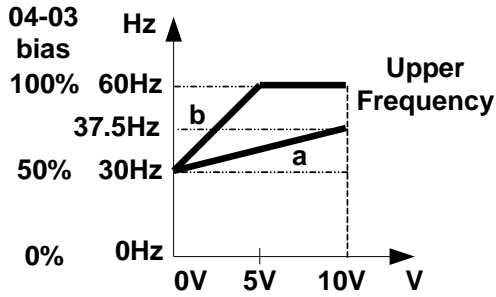

Figure8:

	04-02	04-03	04-04	04-05
c	50%	50%	0	1
d	200%	50%	0	1

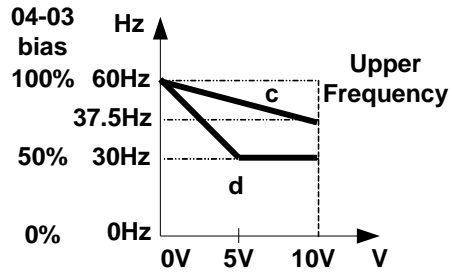

Figure9:

	04-02	04-03	04-04	04-05
e	50%	20%	1	0
f	200%	20%	1	0

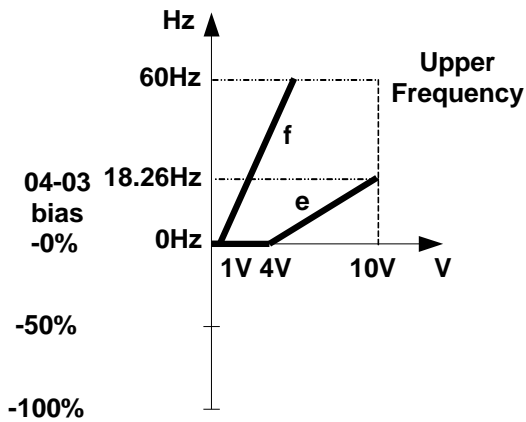
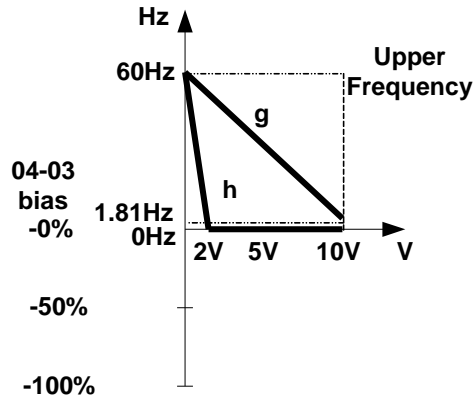

Figure10:

	04-02	04-03	04-04	04-05
g	50%	50%	1	1
h	200%	0%	0	1



04-11	Analog Output (AO) Function Selection.
Range	【0】 :Output Frequency 【1】 :Frequency Command 【2】 :Output Voltage 【3】 :DC Bus Voltage 【4】 :Output Current

Example: Set 04-11 as required according to the table below.

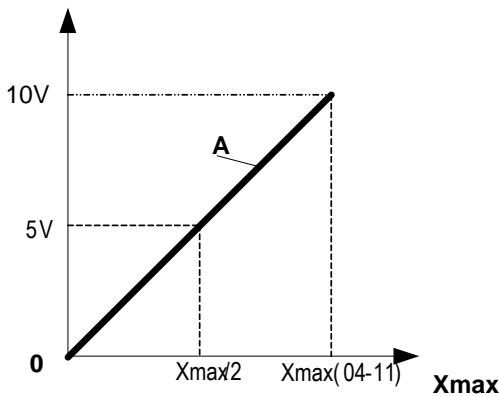

04-11	A	Xmax
【0】	Output frequency	upper frequency limit
【1】	Frequency Setting	upper frequency limit
【2】	Output voltage	Motor Rated Voltage
【3】	DC Bus Voltage	230V: 0~400VDC 460V: 0~800VDC
【4】	Output current	rated current of inverter

04-12	AO Gain
Range	【0 ~ 1000】 %
04-13	AO Bias
Range	【0 ~ 100】 %
04-14	AO Bias Selection
Range	【0】 : positive 【1】 : Negative
04-15	AO Slope
Range	【0】 : positive 【1】 : Negative
04-16	F-Gain
Range	【0】 : Invalid 【1】 : Effective

- Set Analog output function (04-11).
- Output level is 0-10Vdc.
- Output voltage level can be scaled and adjusted with parameters 04-12 to 04-15 if needed.
- The analog output scaling is the same as examples shown previously for Analog Voltage Input (AI1) parameters 4-02 to 4-05.

Note: The max output voltage is 10Vdc based on the inverter hardware. Use external devices that require a maximum of 10Vdc signal.

07-00	Momentary power loss and restart
Range	【0】 :Momentary Power Loss and Restart Disable 【1】 :Momentary Power Loss and Restart Enable

Inverter output will be turned off during a sudden drop in input voltage below the under voltage level.

07-00=0: Inverter trips on “UV” fault on power loss and will not restart.

07-00=1: Inverter resumes operation at half of the output frequency before power-loss after power has been restored. There is no limitation on the number of restarts.

The momentary power loss function is enabled as long as the inverter CPU still has power and the inverter will restart when power is restored based on the setting of parameters 00-02, 07-04 and status of External run command.

Caution: After a power loss and Run mode is set to External Run (00-02=1) and Direct start on power up is enabled (07-04=0) the inverter will automatically start when power is restored.

To ensure safety of operators and to avoid any damages to the machinery, all necessary safety measure must be taken and an inverter input disconnect switch must be used.

07-01	Auto Restart Delay Time
Range	【0.0~800.0】 s
07-02	Number of Auto Restart Attempts
Range	【0~10】

Automatic restart operation:

07-02= **【0】** , the inverter will not perform an automatic restart

07-02> **【0】** , 07-01= **【0】**

Fault is detected. The inverter turns off the output, displays the fault on the keypad and waits 0.5 sec. before accepting another run / automatic restart command.

07-02> **【0】** , 07-01> **【0】**

Active fault is reset and a speed search operation is performed. The time between each fault restart attempt is set by parameter 07-01.

When the total number of restart attempts has exceed the number of automatic restart attempts set in parameter 07-02, the inverter will turn off the output and the fault contact is activated.

When the automatic restart function is enabled the internal automatic restart attempt counter is reset based on the following actions:

1. No fault occurs in 10 minutes or longer after the automatic restart
2. Reset command to clear fault via input terminal or using the keypad
3. Power to the inverter is turned off and back on again

The automatic restart function can be used for the following faults. Please note that when the fault is not listed in the table the inverter will not attempt an automatic restart.

- OC-S** Over current at start
- OV-C** Over voltage during operation / deceleration
- PF** Input phase loss
- OC** Over current
- OL1** Motor overload
- OL2** Motor overload
- OL3** Over Torque
- LV** Low voltage during operation
- OVSP** Over Speed
- LIFE 1** Maintenance required input surge protection circuit
- LIFE 2** Maintenance required control Circuit main capacitors
- LIFE 3** Maintenance required DC-bus capacitors

Note: Auto restart after a fault will not function during DC injection braking or decelerating to stop.

08-00	Trip Prevention Selection
Range	【xxxx0】 :Enable Trip Prevention During Acceleration 【xxxx1】 :Disable Trip Prevention During Acceleration 【xx0x】 :Enable Trip Prevention During Deceleration 【xx1x】 :Disable Trip Prevention During Deceleration 【xx0xx】 :Enable Trip Prevention in Run Mode 【xx1xx】 :Disable Trip Prevention in Run Mode 【x0xxx】 :Enable over voltage Prevention in Run Mode 【x1xxx】 :Disable over voltage Prevention in Run Mode

08-01	Trip Prevention Level During Acceleration
Range	【50 ~ 200】 %

- Trip prevention adjustment level during acceleration to prevent over current (OC-A) trips.
- If trip prevention during acceleration is enabled and an over current condition occurs due to a heavy load, the acceleration is put on hold until the output current drops below the setting of parameter 08-01 after which acceleration resumes.

08-02	Trip Prevention Level During Deceleration
Range	【50 ~ 200】 %

- Trip prevention adjustment level during deceleration to prevent over Voltage (OV-C) trips.
- If trip prevention during deceleration is enabled and an over voltage condition occurs during stopping due to the load (regenerative energy), deceleration is put on hold until the output current level falls below the setting of parameter 08-02 after which deceleration resumes.

08-03	Trip Prevention Level During Continuous Run Mode
Range	【50 ~ 200】 %

- Trip prevention adjustment level during continuous Run to prevent over current (OC-C) trips.
- If trip prevention during continuous Run is enabled and an over current occurs due the load such as a sudden transient load, the output frequency is reduced by decelerating to a lower speed until the over current level falls

below the setting of parameter 08-0301 after which acceleration resumes back to the target frequency.

08-04	Over Voltage Prevention Level During Run Mode
Range	【350.0VDC~390.0VDC】 (230V class) 【700.0VDC~780.0VDC】 (460V class)

- Over voltage prevention level can be set by parameter 08-04 if needed.
- When the DC bus voltage rises above level set in 08-04 an over voltage fault will occur.

08-05	Electronic Motor Overload Protection Operation Mode (OL1)
Range	【0】 : Disable 【1】 : Enable

The electronic motor overload protection function estimates the motor overload level based on the output current, output frequency, motor characteristics and time. The motor overload trip time depends on the motor rated current when the output current is greater than motor FLA.

12-00	Display Mode
Range	0 0 0 0 0 MSD LSD 00000~88888 Each digit can be set from 0 to 8 as listed below. 【0】 :Disable display(frequency& parameters) 【1】 :output Current 【2】 :output Voltage 【3】 :DC voltage 【4】 :Temperature 【5】 :PID feedback 【6】 :AI1 【7】 :AI2 【8】 :Count Status

Note: The highest bit is used for power-up monitor. The 4 least significant bits can be used to customize the display sequence see chapter 4.1.3.

12-01	PID Feedback Display format
Range	【0】 :Displayed in Integer (xxx) 【1】 :One Decimal Place (xx.x) 【2】 :Two Decimal Places (x.xx)
12-02	PID Feedback Display Unit Setting
Range	【0】 :xxx-- 【1】 :xxxpb(pressure) 【2】 :xxxfl(flow)

12-03	Custom Units (Line Speed) Display Mode
Range	【0~65535】 Rpm

Set motor rated RPM for the inverter to display the actual motor speed based on the output frequency.
 Motor synchronous speed = 120 x Rated frequency ÷ Number of poles.

12-04	Custom Units (Line Speed) Display Mode
Range	【0】 :Drive Output Frequency is Displayed 【1】 :Line Speed is Displayed in Integer (xxxxx) 【2】 :Line Speed is Displayed with One Decimal Place (xxxx.x) 【3】 :Line Speed is Displayed with Two Decimal Places (xxx.xx) 【4】 :Line Speed is Displayed with Three Decimal Places (xx.xxx)

12-04≠0, line speed is displayed while the inverter is running or stopped.

12-05	Inputs and output Logic status display (S1 to S6) & RY1~2
Range	Read only(Panel read only)

Terminals S1-S6 are represented using two segments of each digit. Segment turns on when input is active. The bottom segments of each of the first three digits are used to represent the digital outputs (R1, R2, DO1). Segments turn on when output is active.

Example1: S1~S6 are ON

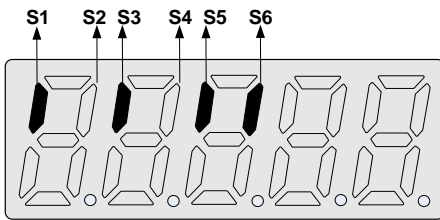

Example2: RY1, RY2 and PLC are ON

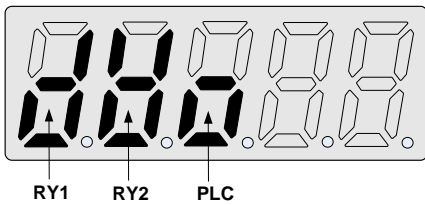

13-02	Fault Log Display (Latest 3 faults)
Range	----

Last three faults are stored using FIFO mechanism, whenever a new fault occurs the previous faults are pushed down. Example: Fault stored in 2.xxx is moved to 3.xxx and 1.xxx is moved to 2.xxx. The most recent fault will be stored on position 1.xxx.

Notes:

- Use Up▲ and Down▼ keys to scroll between the fault registers.
- Pressing the reset key when parameter 13-02 is displayed will clear all three fault registers and the display for each register will change to 1. ---, 2. ---, 3. ---.
- Fault log content 1.OC-C'; means that most recent fault is OC-C, etc...

13-08	Reset Drive to Factory Settings
Range	【1150】 : Reset to factory setting. 50Hz system 【1160】 : Reset to factory setting. 60 Hz system. 【1112】 : RESET PLC

Use parameter 13-08 to initialize the inverter to factory default. It is recommended to write down the modified parameters before initializing the inverter. After initialization, the value of 13-08 will return to zero automatically.

Appendix: UL Instructions

Danger

Electric Shock Hazard

**Do not connect or disconnect wiring while the power is on.
Failure to comply will result in death or serious injury.**

Warning

Electric Shock Hazard

Do not operate equipment with covers removed.

Failure to comply could result in death or serious injury.

The diagrams in this section may show inverters without covers or safety shields to show details. Be sure to reinstall covers or shields before operating the inverters and run the inverters according to the instructions described in this manual.

Always ground the motor-side grounding terminal.

Improper equipment grounding could result in death or serious injury by contacting the motor case.

Do not touch any terminals before the capacitors have fully discharged.

Failure to comply could result in death or serious injury.

Before wiring terminals, disconnect all power to the equipment. The internal capacitor remains charged even after the power supply is turned off. After shutting off the power, wait for at least the amount of time specified on the inverter before touching any components.

Do not allow unqualified personnel to perform work on the inverter.

Failure to comply could result in death or serious injury.

Installation, maintenance, inspection, and servicing must be performed only by authorized personnel familiar with installation, adjustment, and maintenance of inverters.

Do not perform work on the inverter while wearing loose clothing, jewelry, or lack of eye protection.

Failure to comply could result in death or serious injury.

Remove all metal objects such as watches and rings, secure loose clothing, and wear eye protection before beginning work on the inverter.

Do not remove covers or touch circuit boards while the power is on.

Failure to comply could result in death or serious injury.

Warning

Fire Hazard

Tighten all terminal screws to the specified tightening torque.

Loose electrical connections could result in death or serious injury by fire due to overheating of electrical connections.

Do not use an improper voltage source.

Failure to comply could result in death or serious injury by fire.

Verify that the rated voltage of the inverter matches the voltage of the incoming power supply before applying power.

Do not use improper combustible materials.

Failure to comply could result in death or serious injury by fire. Attach the inverter to metal or other noncombustible material.

NOTICE

Observe proper electrostatic discharge procedures (ESD) when handling the inverter and circuit boards.

Failure to comply may result in ESD damage to the inverter circuitry.

Never connect or disconnect the motor from the inverter while the inverter is outputting voltage.

Improper equipment sequencing could result in damage to the inverter.

Do not use unshielded cable for control wiring.

Failure to comply may cause electrical interference resulting in poor system performance. Use shielded twisted-pair wires and ground the shield to the ground terminal of the inverter.

Do not modify the inverter circuitry.

Failure to comply could result in damage to the inverter and will void warranty. TECO is not responsible for any modification of the product made by the user. This product must not be modified.

Check all the wiring to ensure that all connections are correct after installing the inverter and connecting any other devices.

Failure to comply could result in damage to the inverter.

❖ **UL Standards**

The UL/cUL mark applies to products in the United States and Canada and it means that UL has performed product testing and evaluation and determined that their stringent standards for product safety have been met. For a product to receive UL certification, all components inside that product must also receive UL certification.



❖ **UL Standards Compliance**

This inverter is tested in accordance with UL standard UL508C and complies with UL requirements. To ensure continued compliance when using this inverter in combination with other equipment, meet the following conditions:

■ **Installation Area**

Do not install the inverter to an area greater than pollution severity 2 (UL standard).

■ Main Circuit Terminal Wiring

UL approval requires crimp terminals when wiring the inverter's main circuit terminals. Use crimping tools as specified by the crimp terminal manufacturer. TECO recommends crimp terminals made by NICHIFU for the insulation cap.

The table below matches inverter models with crimp terminals and insulation caps. Orders can be placed with a TECO representative or directly with the TECO sales department.

Closed-Loop Crimp Terminal Size

Drive Model	Wire Gauge mm ² , (AWG)		Terminal	Crimp Terminal	Tool	Insulation Cap
	R/L1 / S/L2 / T/L3	U/T1 / V/T2 / W/T3				
E510			Screws	Model No.	Machine No.	Model No.
201	2.1 (14)		M3.5	R2-3.5	Nichifu NH 1 / 9	TIC 2
202	3.3(12)		M4	R3.5-4	Nichifu NH 1 / 9	TIC 3.5
202-H3	2.1 (14)		M3.5	R2-3.5	Nichifu NH 1 / 9	TIC 2
205	5.3(10)		M4	R5.5-4	Nichifu NH 1 / 9	TIC 5.5
210	8.4(8)		M5	R8-5	Nichifu NH 1 / 9	TIC 8
220	21.2(4)		M5	R22-5	Nichifu NOP 150H	TIC 22
402	2.1 (14)		M3.5	R2.3.5	Nichifu NH 1 / 9	TIC 2
405	2.1 (14)		M4	R2.3.5	Nichifu NH 1 / 9	TIC 2
415	8.4(8)		M5	R8-5	Nichifu NH 1 / 9	TIC 8
425	8.4(8)		M5	R8-5	Nichifu NH 1 / 9	TIC 8

❖ Type 1

During installation, all conduit hole plugs shall be removed, and all conduit holes shall be used.

Recommended Input Fuse Selection

Drive Model E510	Fuse Type	
	Manufacturer: Bussmann / FERRAZ SHAWMUT	
	Model	Fuse Ampere Rating (A)
	230 V Class Single / Three-Phase Drives	
2P5-HXXX	Bussmann 20CT	690V 20A
201-HXXX	Bussmann 20CT	690V 20A
202-HXXX	Bussmann 35FE	690V 35A
203-HXXX	Bussmann 50FE	690V 50A
2P5-H3XX	Bussmann 20CT	690V 20A
201-H3XX	Bussmann 20CT	690V 20A
202-H3XX	Bussmann 20CT	690V 20A
203-H3XX	Bussmann 30FE	690V 30A
205-XXXX	Bussmann 50FE	690V 50A
208-XXXX	Bussmann 63FE	690V 63A
210-XXXX	FERRAZ SHAWMUT A50QS100-4	500V 100A
215-XXXX	Bussmann 120FEE / FERRAZ A50QS150-4	690V 120A / 500V 150A
220-XXXX	FERRAZ SHAWMUT A50QS150-4	500V 150A

Drive Model E510	Fuse Type	
	Manufacturer: Bussmann / FERRAZ SHAWMUT	
	Model	Fuse Ampere Rating (A)
	460 V Class Three-Phase Drives	
401-XXXX	Bussmann 10CT	690V 10A
402-XXXX	Bussmann 16CT	690V 16A
403-XXXX	Bussmann 16CT	690V 16A
405-XXXX	Bussmann 25ET	690V 25A
408-XXXX	Bussmann 40FE	690V 40A
410-XXXX	Bussmann 50FE	690V 50A
415-XXXX	Bussmann 63FE	690V 63A
420-XXXX	Bussmann 80FE	690V 80A
425-XXXX	FERRAZ SHAWMUT A50QS100-4	500V 100A

Motor Over Temperature Protection

Motor over temperature protection shall be provided in the end use application.

■ Field Wiring Terminals

All input and output field wiring terminals not located within the motor circuit shall be marked to indicate the proper connections that are to be made to each terminal and indicate that copper conductors, rated 75°C are to be used.

■ Inverter Short-Circuit Rating

This inverter has undergone the UL short-circuit test, which certifies that during a short circuit in the power supply the current flow will not rise above value. Please see electrical ratings for maximum voltage and table below for current.

- The MCCB and breaker protection and fuse ratings (refer to the preceding table) shall be equal to or greater than the short-circuit tolerance of the power supply being used.
- Suitable for use on a circuit capable of delivering not more than (A) RMS symmetrical amperes for (HP) HP in 240 / 480 V class drives motor overload protection.

Horse Power (HP)	Current (A)	Voltage (V)
1 - 50	5,000	240 / 480
51 - 200	10,000	240 / 480
201 - 400	18,000	240 / 480
401 - 600	30,000	240 / 480

❖ Inverter Motor Overload Protection

Set parameter 02-01 (motor rated current) to the appropriate value to enable motor overload protection. The internal motor overload protection is UL listed and in accordance with the NEC and CEC.

■ 02-01 Motor Rated Current

Setting Range Model Dependent

Factory Default: Model Dependent

The motor rated current parameter (02-01) protects the motor. The motor protection parameter 08-05 is set as factory default. Set 02-01 to the full load amps (FLA) as shown on the nameplate of the motor.

■ 08-05 Motor Overload Protection Selection

The inverter has an electronic overload protection function (OL1) based on time, output current, and output frequency, which protects the motor from overheating. The electronic thermal overload function is UL-recognized, so it does not require an external thermal overload relay for single motor operation.

This parameter selects the motor overload curve used according to the type of motor applied.

08-05	Selection for motor overload protection (OL1)
Range	0: Disabled 1: Enabled

Sets motor overload protection function in parameter 08-05 according to the applicable motor.

08-05 = 0: Disables the motor overload protection function when two or more motors are connected to a single inverter. Use an alternative method to provide separate overload protection for each motor such as connecting a thermal overload relay to the power line of each motor.

08-05 = 1: The motor overload protection function should be set to hot start protection characteristic curve when the power supply is turned on and off frequently, because the thermal values are reset each time when the power is turned off.

■ 08-06 Motor Overload Operation Selection

08-06	Start-up mode of overload protection operation (OL1)
Range	0: Coast-to-Stop After Overload Protection is Activated 1: Drive Will Not Trip when Overload Protection is Activated (OL1)

08-06=0: When the inverter detects a motor overload the inverter output is turned off and the OL1 fault message will flash on the keypad. Press RESET button on the keypad or activate the reset function through the multi-function inputs to reset the OL1 fault.

08-06=1: When the inverter detects a motor overload the inverter will continue running and the OL1 alarm message will flash on the keypad until the motor current falls within the normal operating range.

■ 08-11 Motor Type Selection

08-11	Start-up mode of overload protection operation (OL1)
Range	0: Standard Motor 1: Inverter Duty Motor

08-11=0: For motors with forced cooling

08-12=1: For motors without forced cooling

■ **08-12 Motor Overload Protection Curve**

08-12	Start-up mode of overload protection operation (OL1)
Range	0: Motor Overload Protection for General loads (OL=103 %) (150% for 1 Minute) 1: Motor Over load Protection for HVAC (Fan & Pump) (OL=113%) (123% for 1 Minute)

08-12=0: For constant torque applications with a load less than 103% of the motor rated current. If the load is greater than 150% of the motor rated current, the motor will run for 1 minute before faulting on motor overload.

08-12=1: For variable torque applications (Fan, Pumps...) with a load less than 113% of the motor rated current. If the load is greater than 123% of the motor rated current, the motor will run for 1 minute before faulting on motor overload.

TECO   **Westinghouse**

INVERTER

E510

Teco-Westinghouse Motor Company
5100 N. IH-35
Round Rock, Texas 78681
1-800-279-4007
www.tecowestinghouse.com

Distributor

Ver 01: 2015.08