

INVERTER



(SENSORLESS VECTOR)

INSTRUCTION MANUAL

220V Class 3 Φ 25~100HP
440V Class 3 Φ 25~400HP

Please hand this manual to the end-users. It will be of great help for their daily operation, maintenance, inspection and troubleshooting.

BEFORE INSTALLATION & USE

1. Ensure nameplate data corresponds with your requirements.
2. Ensure the apparatus is undamaged.

WARNING

The following safety precautions must be observed:

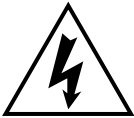

1. Electric apparatus and electricity can cause serious or fatal injury if the apparatus is improperly installed, operated or maintained. Responsible personnel must be fully trained to understand the hazards to themselves and others before being involved in installing, operating, maintaining and decommissioning electrical apparatus. European Union Safety information can be obtained from such as:

BS4999;
IEE

EN60204-11

Wiring

EN292-1

EN294
Regulations

Particular industries and countries have further safety requirements. Refer to their trade safety bodies, British Standards Institution, Dept. of Trade & Industry, etc., for further information. For instance, in the USA, refer to NEMA MG2, the National Electrical Code, local safety requirements, etc.



2. When servicing, all power sources to the apparatus and to the accessory devices should be de-energized and disconnected and all moving parts at standstill.
3. Safety guards and other protective, devices must neither be bypassed nor rendered inoperative.



4. The apparatus must be earthed. Refer to relevant standards such as EN60204-1, IEE Wiring Regulation etc.
5. A suitable enclosure must be provided to prevent access to live parts. Extra caution should be observed around apparatus that is automatically started or has automatic resetting relays or is remotely started in case such starting means has not been properly disabled and the apparatus starts unexpectedly.

CAUTION AND WARNING:

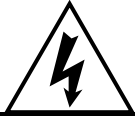

WARNING

- Do not change the wiring while power is applied to the circuit.
- After turning OFF the main circuit supply, do not touch circuit components until CHARGE LED is extinguished.
- Never connect power circuit output U (T1), V (T2), W (T3) to AC power supply.
- When the retry function (Cn-36) is selected, motor may restart suddenly after being stopped by momentary power loss.



CAUTION

- When mounting units in a separate enclosure, install a fan or other cooling device to keep the intake air temperature below 45°C.
- Do not perform a withstand voltage test to the inverter.
- All the constants of the inverter have been factory preset. Do not change the settings unnecessarily.

CONTENTS

PART I INSTALLATION MANUAL	Pages
1. GENERAL	5
1.1 SAFE OPERATION NOTES.....	5
1.2 PRODUCT CHANGES.....	5
2. RECEIVING	6
3. INSTALLATION	7
3.1 MOUNTING SPACE.....	7
3.2 LOCATION	8
4. WIRING	9
4.1 NOTES ON WIRING TO PERIPHERAL UNITS	9
4.2 CONNECTION DIAGRAM	10
4.3 TERMINAL FUNCTION.....	11
4.3.1 MAIN CIRCUIT TERMINALS	11
4.3.2 CONTROL CIRCUIT TERMINALS.....	11
4.3.3 MAIN CIRCUIT SCHEMATIC.....	12
4.4 WIRING PARTS	13
4.4.1 RECOMMENDED WIRING PARTS	13
4.4.2 CAUTIONS FOR WIRING	15
5. TEST OPERATION	17
5.1 CHECK BEFORE TEST OPERATION	17
5.2 SETTING THE LINE VOLTAGE SELECTING CONNECTOR.....	17
6. MAINTENANCE	18
6.1 PERIODIC INSPECTION.....	18
6.2 SPARE PARTS	19
7. SPECIFICATIONS	21
8. DIMENSIONS	23
9. PERIPHERAL AND OPTIONS	26
9.1 AC REACTOR.....	26
9.2 NOISE FILTER.....	27
9.2.1 INPUT NOISE FILTER	27
9.2.2 EMI SUPPRESSION ZERO CORE	28

9.3 BRAKING RESISTOR AND BRAKING UNIT	29
9.4 OTHERS	30
9.4.1 DIGITAL OPERATOR WITH EXTENSION WIRE	30
9.4.2 ANALOG OPERATOR	31
9.4.3 LED DIGITAL OPERATOR.....	31
9.4.4 OPTION CARDS.....	32

PART II OPERATION MANUAL	Pages
1. DESCRIPTION OF USING 7200GS.....	35
1.1 Using LCD (OR LED) digital operator	35
1.2 DRIVE mode and PRGM mode displayed contents	37
1.3 Parameter description	38
1.4 Sample example of using LCD digital operator	39
1.5 Control mode selection	41
2. SETTING USER CONSTANT	42
2.1 Descriptions of Constant / function list	42
2.2 Frequency Command An-□□	43
2.3 Parameters Can Be Changed during Running Bn-□□	44
2.4 System Parameters Sn-□□	51
2.5 Control Parameters Cn-□□	109
2.6 Monitoring Parameters Un-□□	129
3. FAULT DISPLAY AND TROUBLE SHOOTING	131
4. APPENDIX:	
A. SENSORLESS VECTOR CONTROL	139
B. AUTO ENERGY-SAVING CONTROL IN PID CONTROL MODE	142
C. PID CONTROL IN PID CONTROL MODE	147
D. PG FEEDBACK CONTROL	153
E. NOTES ON APPLICATION OF MOTORS	157
F. PERIPHERAL UNIT NOTES	158
G. CIRCUIT PROTECTION AND ENVIRONMENTAL RATING NOTES	159
H. DRIVE INPUT FUSES	161
I. CERTIFICATION FOR THE INVERTER	162

PART I

INSTALLATION MANUAL

1. GENERAL

1.1 SAFE OPERATION NOTES

Read this installation manual thoroughly before installation, operation, maintenance or inspection of the inverter. Only authorized personnel should be permitted to perform maintenance, inspections or parts replacement.

In this manual, notes for safe operation are classified as:

"WARNING" or "CAUTION".



: Indicates a potentially hazardous situation which, if not avoided, could result in death or serious injury to personnel.



: Indicates a potentially hazardous situation which, if not avoided, may result in minor or moderate injury to personnel and damage to equipment. It may also be used to alert against unsafe practices.

This inverter has been placed through demanding tests at the factory before shipment. After unpacking, check for the following:

1. Verify that part numbers on shipping carton and unit match the purchase order sheet and/or packing list.
2. Do not install or operate any inverter which is damaged or missing parts.
3. Do not install or operate any inverter which has no QC marking.

Contact your local distributor or TECO representative if any of the above have been found.

1.2 PRODUCT CHANGES

TECO reserves the right to discontinue or make modifications to the design of its products without prior notice, and holds no obligation to make modifications to products sold previously. TECO also holds no liability for losses of any kind which may result

from this action.

2. RECEIVING



CAUTION

This 7200GS has been put through demanding tests at the factory before shipment. After unpacking, check the followings.

- Verify the received product with the purchase order sheet (invoice) and/or packing list.
- Transit damage.

If any part of 7200GS is damaged or lost, immediately notify the shipper.

NAMEPLATE DATA (220V CLASS 75HP example)

MODE	JNTEBGBA0075JK- - -	← Inverter Model
	220V CLASS INVERTER	← Input Spec.
INPU	AC 3PH 200-230V 50/60Hz	← Output Spec.
OUTPU	AC 3PH 0-230V 81KVA 212A	← Series No.
SER. NO.		
東元電機股份有限公司 TECO Electric & Machinery Co., Ltd.		← CE Mark
		

MODEL DESIGNATION

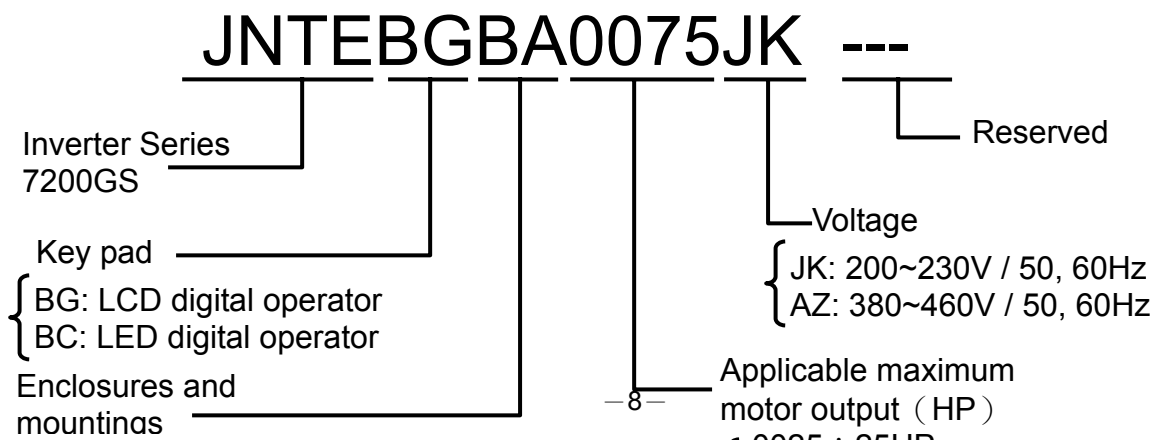

3. INSTALLATION



CAUTION

- Never move, lift or handle the 7200GS cabinet by the front cover.
- Lift the cabinet from the bottom.
- Do not drop the inverter.

3.1 MOUNTING SPACE

Install 7200GS vertically and allow sufficient space for effective cooling as shown in Fig. 1.

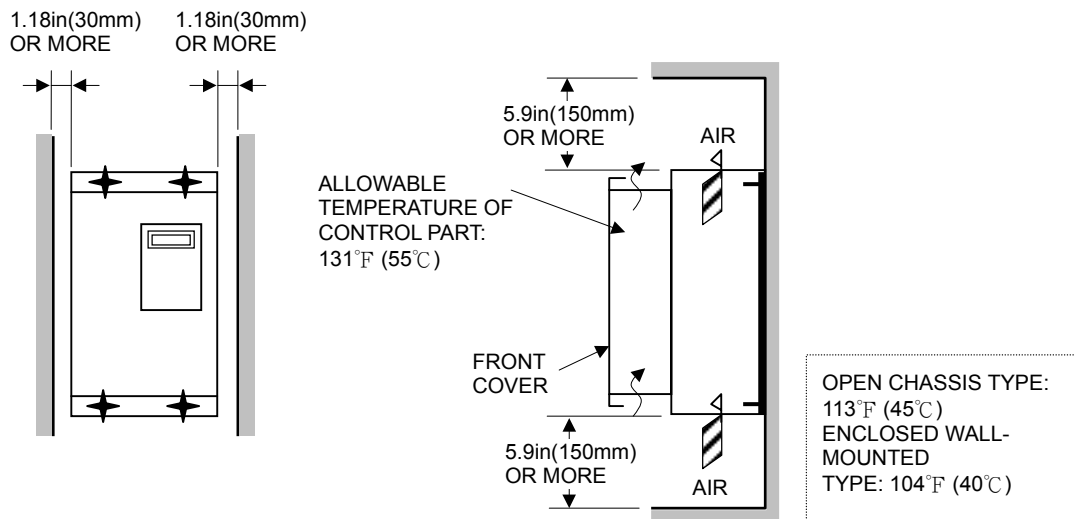

(a) Front View

(b) Side View

Note: For product external dimensions and mounting dimensions, refer to "DIMENSIONS" on page 23.

Fig. 1 Mounting Spaces

3.2 LOCATION

Location of the equipment is important to achieve proper performance and normal operating life. The 7200GS should be installed in areas where the following conditions exist:

- Protected from rain or moisture.
- Protected from direct sunlight.
- Protected from corrosive gases or liquids.
- Free from airborne dust or metallic particles.
- Free from vibration.
- Free from magnetic noise (e.g. welding machines, power units)
- Ambient temperature:
 - +14 to 104°F, -10 to +40°C (For enclosed type),
 - +14 to 113°F, -10 to +45°C (For open chassis type)
- Free from combustible materials, gases, etc.



CAUTION

When mounting multiple units in a common enclosure, install a cooling fan or some other means to cool the air entering the inverter to at least 113°F (45°C) or below.

4. WIRING

4.1 NOTES ON WIRING TO PERIPHERAL UNITS

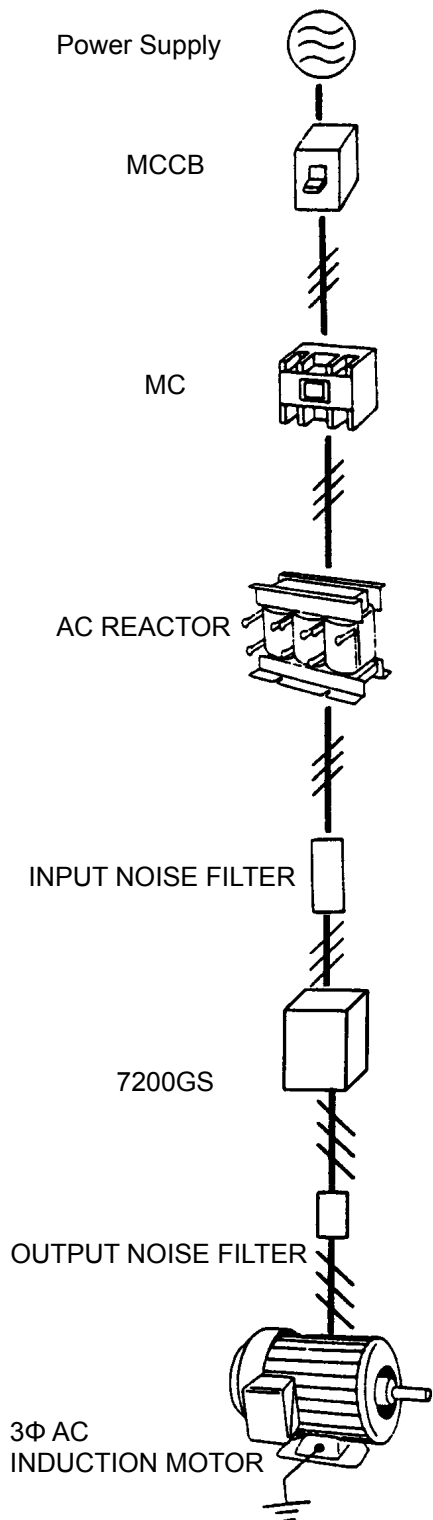

- **MCCB (molded case circuit breaker)**
Please refer to Table 1. for MCCB selection.
Do not use a circuit breaker for start/stop operation.
When a ground fault interrupter is used, select the one with no influence for high frequency. Setting current should be 200mA or above and the operating time at 0.1 second or longer to prevent malfunction.
- **MC (magnetic contactor)**
It is not always necessary to have the MC on the input side. However, an input MC can be used to prevent an automatic restart after recovery from an external power loss during remote control operation.
Do not use the MC for start/stop operation.
- **AC REACTOR**
To improve power factor or to reduce surge, install an AC reactor. There is a DC choke built-in on 7200GS, models 25HP(18.5 KW) and larger for 220V class and 30HP(22 KW) and larger for 440V class. The 440V 300 ~ 400HP need to install AC reactor externally.
- **Input Noise Filter**
When used with specified input noise filter, the 7200GS can comply with EN55011 class A. Please refer to our EMC technical manual for noise filter selection.
- **Inverter**
Wire input to terminals L1, L2 and L3 for three phase input. Make sure to connect the ground terminal to an appropriate safety ground.
- **Output Noise Filter (EMI Suppression zero core)**
When used with output noise filter, radiated and conducted emissions may be reduced.
- **Motor**
When multiple motors are driven in parallel with an inverter, the inverter rated current should be at least 1.1 times the total motor rated current. Make sure that the motor and the inverters are separately grounded.

4.2 CONNECTION DIAGRAM

The following diagram shows interconnection of the main circuit and control circuit. With the digital operator, the motor can be operated by wiring the main circuit only. (Terminal Symbols: ⊙ indicates main circuit; ○ indicates control circuit).

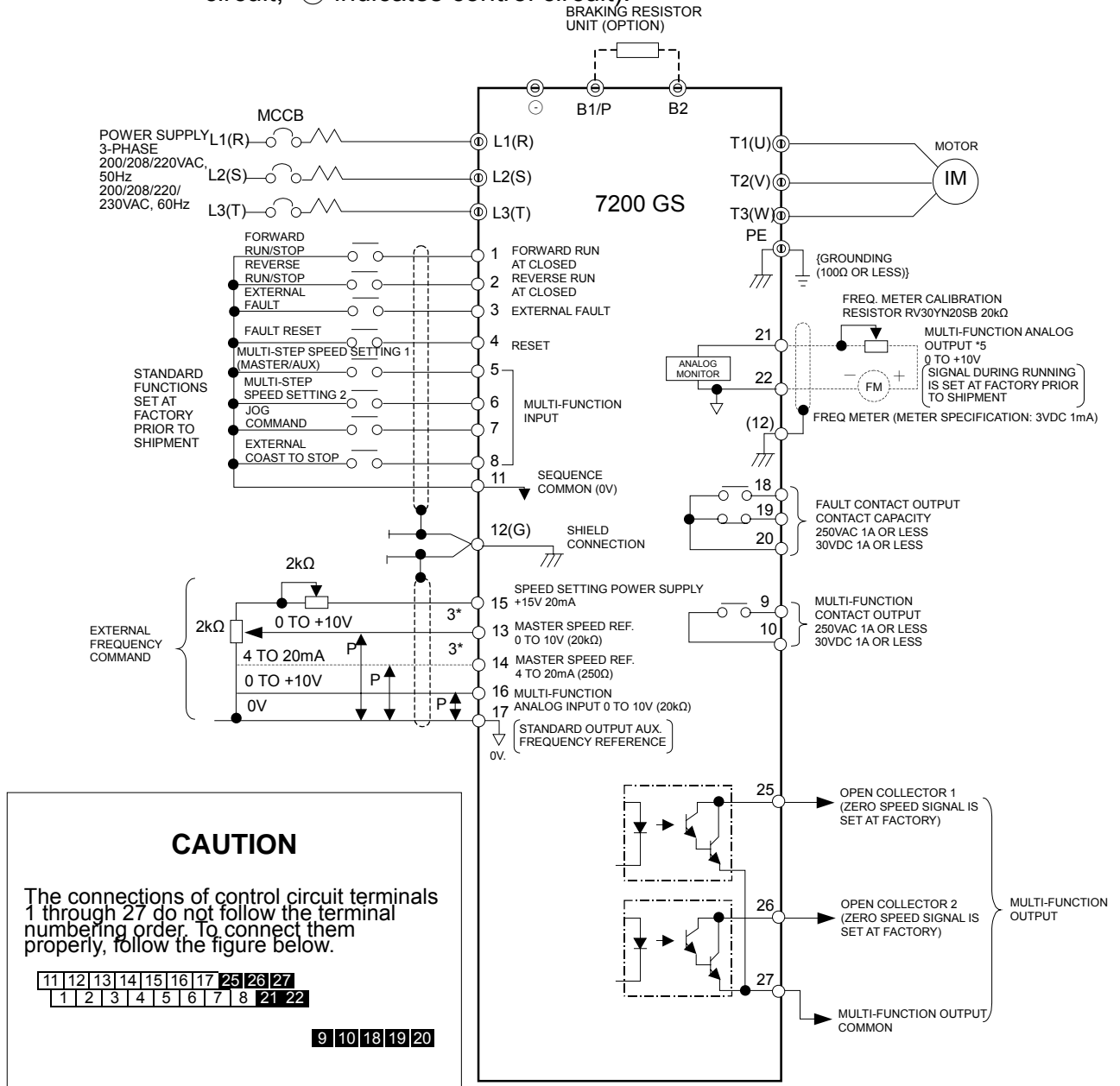

Notes:

- indicates shielded wire and twisted pair shielded wire.
- Control circuit terminal 15 of +15V has maximum output current capacity of 20mA.
- Either external terminal 13 or 14 can be used.
(For simultaneous input, two signals are internally added in the unit).
- Multi-function analog output is an exclusive meter output such as frequency meter etc. and not available for the feedback control system.
- Control circuit terminal 12 is frame ground of the unit.

Fig. 2 Standard connection diagram.

4.3 TERMINAL FUNCTION

4.3.1 MAIN CIRCUIT TERMINALS

Table 1. Main Circuit Terminals

HP Range Terminals	440V: 25HP	220V: 25~100HP 440V: 30~400HP
R / L1	Main Circuit Input Power Supply	
S / L2		
T / L3		
U / T1	Inverter Output	
V / T2		
W / T3		
B1/P	● B1/P - B2: Braking Resistor ● B1/P - ⊖: DC power supply	—
B2		
⊖		● ⊕~⊖: DC Power Supply or Braking Unit
⊕	—	
E (PE)	Grounding (3rd Type Grounding)	

4.3.2 CONTROL CIRCUIT TERMINALS

Table 2. Control Circuit Terminals

Terminal	Functions	
1	Forward operation-stop signal	
2	Reverse operation-stop signal	
3	External fault input	
4	Fault reset	
5	Multi-function contact input: the following signals available to select. Forward/reverse select, run mode select, multi-speed select, jog frequency select, accel/decel time select, external fault, external coast to stop, hold command, inverter overheat prediction, DB command, aux. input effective, speed search, energy-saving operation.	
6		
7		
8		
9	Multi-function contact output: one of the following signals available to output. Output during running, zero speed, synchronized speed, arbitrary speed agreed, frequency detection, overtorque, undervoltage, run mode, coast to stop, braking resistor overheat, alarm, fault.	
10		
11	Sequence control input common terminal.	
12	Connection to shield sheath of signal lead.	
13	Master speed voltage reference (0 to 10V).	
14	Master speed current reference (4 to 20mA).	
15	+15V	
16	Aux. analog command: one of the following signals available to select. Frequency command, frequency gain, frequency bias, overtorque detection level, voltage bias, accel/decel rate, DB current.	
17	Common terminal for control circuit (0V).	
18	Fault contact output a (Closed at fault).	
19	Fault contact output b (Open at fault).	
20	Fault contact output common.	
21	Multi-function analog monitor (+).	Output current or output frequency is selectable.
22	Multi-function analog monitor (-).	
25	Multi-function PHC output 1.	The same as terminals 9 and 10
26	Multi-function PHC output 2.	
27	Multi-function PHC output common.	

4.3.3 MAIN CIRCUIT SCHEMATIC

<p>1. 440V : 25HP</p>	<p>2. 220V : 25HP 440V : 30HP, 40HP, 50HP</p>
<p>3. 220V : 30HP, 40HP 440V : 60HP, 75HP</p>	<p>4. 220V : 50HP, 60HP, 75HP, 100HP</p>
<p>5. 440V : 100HP</p>	<p>6. 440V : 125HP, 150HP, 175HP, 215HP, 250HP</p>
<p>7. 440V : 300HP, 400HP</p> <p>* External ACL is necessary</p>	

4.4 WIRING PARTS

4.4.1 RECOMMENDED WIRING PARTS

Be sure to connect MCCBs between power supply and 7200GS input terminals L1 (R), L2 (S), L3 (T). Recommended MCCBs are listed in Table 3.

When a ground fault interrupter is used, select the one with no influence for high frequency. The current setting should be 200mA or over and operating time, 0.1 second or over to prevent malfunction.

Table 3. 220V and 440V class applicable wire size and contactor
(a) 220V SERIES

Max. Applicable Motor Output HP (KW) [Note 1]	Cable Size - mm ² (AWG)			Molded-Case Circuit Breaker [Note 4]	Magnetic Contactor [Note 4]
	Power Cable [Note 2]	Ground Cable E [G]	Control Cable [Note 3]		
25(18.5)	22 (4)	14 (6)	0.5~2 (20-14)	TO-225S (150A)	CN-80
30(22)	30 (2)	14 (6)	0.5~2 (20-14)	TO-225S (175A)	CN-100
40(30)	60 (2/0)	22 (4)	0.5~2 (20-14)	TO-225S (175A)	CN-125
50(37)	60×2P (2/0)	22 (4)	0.5~2 (20-14)	TO-225S (200A)	CN-150
60(45)	60×2P (2/0×2P)	22 (4)	0.5~2 (20-14)	TO-225S (225A)	CN-180
75(55)	60×2P (2/0×2P)	30 (2)	0.5~2 (20-14)	TO-400S (300A)	CN-300
100(75)	100×2P (4/0×2P)	50 (1/0)	0.5~2 (20-14)	TO-400S (400A)	CN-300

[Note] 1. For Constant Torque Load.

2. Power Cable Include Cables to the Terminals R (L1), S (L2), T (L3), ⊕ , ⊖ , BR, U (T1), V (T2), W (T3).

3. Control Cable Include Cables to the Control Terminals.

4. The Molded-Case Circuit Breaker and Magnetic Contactors Shown in Table are Taian Products and are for reference only. Other manufactures' equivalent products may be selected.

5. The Magnetic contactors S-K400 and S-K600 are Mitsubishi Products and are for reference only. Other manufactures' equivalent products may be selected.

(b) 440V SERIES

Max. Applicable Motor Output HP (KW) [Note 1]	Cable Size - mm ² (AWG)			Molded-Case Circuit Breaker [Note 4]	Magnetic Contactor [Note 4]
	Power Cable [Note 2]	Ground Cable E [G]	Control Cable [Note 3]		
25(18.5)	8 (8)	8 (8)	0.5~2 (20-14)	TO-100S (75A)	CN-50
30(22)	14 (6)	8 (8)	0.5~2 (20-14)	TO-100S (100A)	CN-50
40(30)	22 (4)	8 (8)	0.5~2 (20-14)	TO-100S (100A)	CN-65
50(37)	22 (4)	14 (6)	0.5~2 (20-14)	TO-125S (125A)	CN-80
60(45)	38 (1)	14 (6)	0.5~2 (20-14)	TO-225S (175A)	CN-100
75(55)	60 (2/0)	22 (4)	0.5~2 (20-14)	TO-225S (175A)	CN-125
100(75)	60×2P (2/0)	22 (4)	0.5~2 (20-14)	TO-225S (225A)	CN-150
125(90)	60×2P (2/0×2P)	30 (2)	0.5~2 (20-14)	TO-400S (300A)	CN-300
150(110)	60×2P (2/0×2P)	30 (2)	0.5~2 (20-14)	TO-400S (300A)	CN-300
175(132)	100×2P (4/0×2P)	50 (1/0)	0.5~2 (20-14)	TO-400S (400A)	CN-300
215(160)	100×2P (4/0×2P)	50 (1/0)	0.5~2 (20-14)	TO-400S (400A)	CN-300
250(185)	250×2P (2P)	50 (1/0)	0.5~2 (20-14)	TO-600S (600A)	S-K400 [Note 5] (450A)
300(220)	250×2P (2P)	60 (2/0)	0.5~2 (20-14)	TO-800S (800A)	S-K600 (800A)
400(300)	250×2P (2P)	60 (2/0)	0.5~2 (20-14)	TE-1000 (1000A)	S-K600 (800A)

4.4.2 CAUTIONS FOR WIRING



CAUTION

The external interconnection wiring must be performed with the following procedures.

After completing 7200GS interconnections, be sure to check that connections are correct. Never use control circuit buzzer check.

(A) MAIN CIRCUIT INPUT/OUTPUT

- (1) Phase rotation of input terminals L1 (R), L2 (S), L3 (T) is available in either direction. (Clockwise and counterclockwise).
- (2) When inverter output terminals T1 (U), T2 (V), and T3 (W) are connected to motor terminals T1 (U), T2 (V), and T3 (W), respectively, motor rotates counterclockwise. (Viewed from opposite side of drive end, upon forward operation command). To reverse the rotation interchange any two of the motor leads.
- (3) Never connect AC main circuit power supply to output terminals T1 (U), T2 (V), and T3 (W). This may cause damage to the inverter.
- (4) Care should be taken to prevent contact of wiring leads with 7200GS cabinet. If this occurs, a short-circuit may result.
- (5) Never connect power factor correction capacitors or noise filters to 7200GS output.
- (6) Never open or close contactors in the output circuit unless inverter is properly sized.



CAUTION

- Lead size should be determined taking into account voltage drop of leads. Voltage drop can be obtained by the following equation: select such lead size that voltage drop will be within 2% of normal rated voltage.
phase-to-phase voltage drop (V)
 $= \sqrt{3} \times \text{lead resistance (}\Omega / \text{km)} \times \text{wiring distance(m)} \times \text{current(A)} \times 10^{-3}$.
- Wiring length between inverter and motor.
If total wiring distance between inverter and motor is excessively long and inverter carrier frequency (main transistor switching frequency) is high, harmonic leakage current from the cable will increase to effect the inverter unit or peripheral devices.
If the wiring distance between inverter and motor is long, reduce the inverter carrier frequency.

(B) GROUNDING (PE: Protective Earth)

Ground the 7200GS through ground terminal E (PE).

- (1) Ground resistance should be 100 ohms or less.
- (2) Never ground 7200GS in common with welding machines, motors, and other large-current electrical equipment, or ground pole. Run the ground lead in separate conduit from leads for large-current electrical equipment.
- (3) Use the ground leads which comply with AWG standards and make the sure the length is as short as possible.
- (4) Where several 7200GS units are used side by side, it is preferable to ground each unit separately to ground poles. However, connecting all the ground terminals of 7200GS in parallel while grounding only one of the 7200GS's to the ground pole is also permissible (Fig. 3). Be sure not to form a loop with the ground leads.

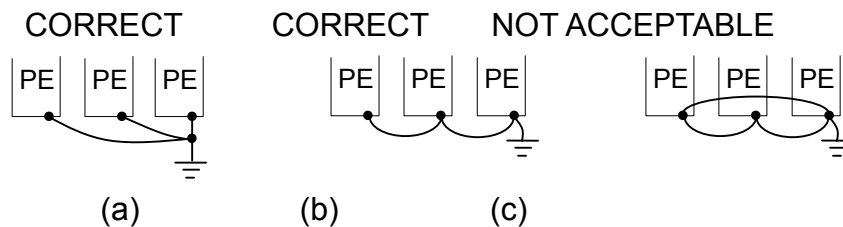

Fig. 3 Grounding of Three 7200GS Units

(C) CONTROL CIRCUIT

- (1) Separation of control circuit leads and main circuit leads: All signal leads must be separated from main circuit leads L1 (R), L2 (S), L3 (T), \oplus , \ominus , B2, T1 (U), T2 (V), T3 (W) and other power cables to prevent erroneous operation caused by noise interference.
- (2) Control circuit leads ⑨, ⑩, ⑱, ⑲, ⑳ (contact output) must be separated from leads 1 to 8, ㉑, ㉒, ㉓, ㉔, ㉕ and ⑪~⑰.
- (3) Use twisted shielded or twisted pair shielded wire for the control circuit line and connect the shield sheath to the inverter terminal E to prevent malfunction caused by noise. See Fig.4. Wiring distance should be less than 164ft (50m).

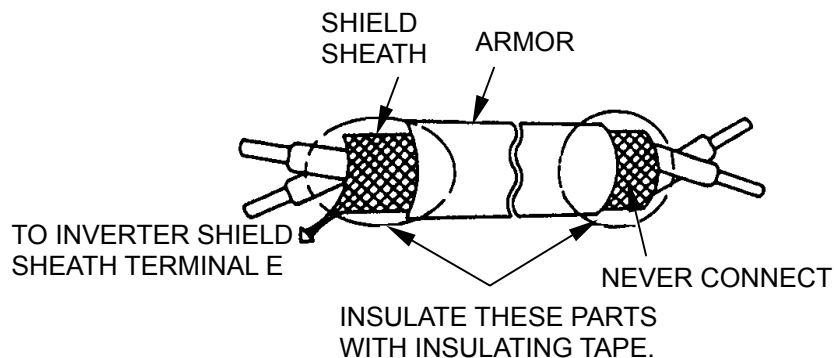

Fig. 4 Shielded Wire Termination

5. TEST OPERATION

To assure safety, prior to test operation, disconnect the coupling or belt which connects the motor with the machine so that motor operation is isolated. If an operation must be performed while the motor is directly connected to the machine, use great care to avoid any possible hazardous condition.

5.1 CHECK BEFORE TEST OPERATION

After completion of installation and wiring, check for

- (1) proper wiring
- (2) short-circuit due to wire clippings
- (3) loose screw-type terminals
- (4) proper load

5.2 SETTING THE LINE VOLTAGE SELECTING CONNECTOR FOR 460V CLASS 30HP (22kW) AND ABOVE

The cooling fan line voltage selecting connector shown in Fig. 5 must be set according to the type of main circuit power supply. Insert the connector at the position showing the appropriate line voltage.

The unit is preset at the factory to 440 line voltage.

(a) 440V CLASS: 30HP ~ 75HP

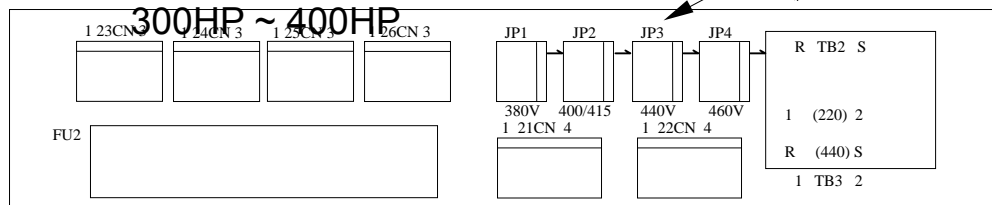

(b) 440V CLASS: 100HP ~ 250HP

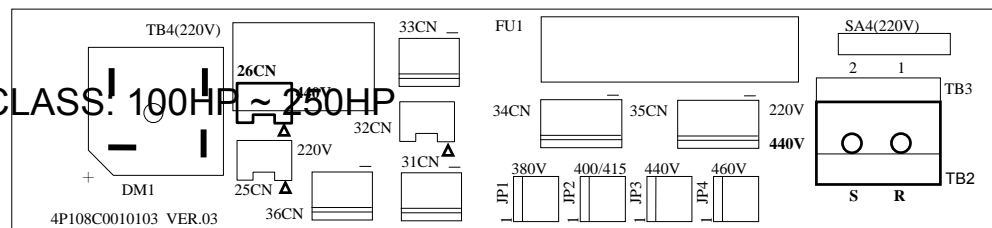

Fig. 5 Voltage Selecting Connector

6. MAINTENANCE

6.1 PERIODIC INSPECTION

The 7200GS requires very few routine checks. It will function longer if it is kept clean, cool and dry. Observe precautions listed in "Location". Check for tightness of electrical connections, discoloration or other signs of overheating. Use Table 4 as your inspection guide. Before servicing, turn OFF AC main circuit power and be sure that CHARGE lamp is OFF.

Table 4 Periodic Inspection

Component	Check	Corrective Action
External terminals, unit mounting bolts, connectors, etc.	Loose screws	Tighten
	Loose connectors	Tighten
Cooling fins	Build-up of dust and dirt	Blow with dry compressed air of 39.2×10^4 to 58.8×10^4 Pa (57 to 85psi.) pressure.
Printed circuit board	Accumulation of conductive dust or oil	Blow with dry compressed air of 39.2×10^4 to 58.8×10^4 Pa (57 to 85psi.) pressure. If dust and oil cannot be removed, replace the board.
Cooling fan	Abnormal noise and vibration. Whether the cumulative operation time exceeds 20,000 hours or not.	Replace the cooling fan.
Power elements	Accumulation of dust and dirt	Blow with dry compressed air of 39.2×10^4 to 58.8×10^4 Pa (57 to 85psi) pressure.
Smoothing capacitor	Discoloration or odor	Replace the capacitor or inverter unit.

Note: Operating conditions as follows:

- Ambient temperature: Yearly average 30°C, 86°F
- Load factor: 80% or less
- Operating time: 12 hours or less per day

Standard Parts Replacement

Item Name	Replacement Cycle	Remarks
Cooling fan	2 or 3 years	Replace with a new product.
Smoothing capacitor	5 years	Replace with a new product. (Determine after examination).
Circuit Breakers and relays	—	Determine after examination.
Fuse	10 years	Replace with a new product.
Aluminum capacitor on PC board	5 years	Replace with a new product. (Determine after examination).

Note: Operating conditions as follows:

- Ambient temperature: Yearly average 30°C, 86°F
- Load factor: 80% or less

- Operating time: 20 hours or less per day

6.2 SPARE PARTS

As insurance against costly downtime, it is strongly recommended that renewal parts be kept on hand in accordance with the table below. When ordering renewal parts, please specify to your local distributor or TECO representative the following information: Part Name, Part Code No. and Quantity.

Table 5 Spare Parts for 220V Class

INVERTER & PARTS NAME		Control PC Board*	Power Board	Main Circuit Transistor	Main Circuit Diode	Cooling Fan
HP	SPEC					
25	MODEL	-	-	CM200DU-12H	DF200BA080	4E-230B
	CODE	4H300D4820002	3P106C0670008	277810212	277192187	3M903D0450004
	Qty	1	1	3	1	2
30	MODEL	-	-	CM200DU-12F	DF200BA080	4E-230B
	CODE	4H300D4820002	4P106C02900B1	277810255	277192187	3M903D0450004
	Qty	1	1	3	1	2
40	MODEL	-	-	CM300HA-12H	2R160E-080	4E-230B
	CODE	4H300D4820002	3P106C06400D4	3H324D0460000	277051532	3M903D0450004
	Qty	1	1	6	6	3
50	MODEL	-	-	CM400HA-12H	2R160E-080	4E-230B
	CODE	4H300D4820002	3P106C06400E2	277800179	277051532	3M903D0450004
	Qty	1	1	6	6	3
60	MODEL	-	-	1MBI600NP-060	2R160E-080	4E-230B
	CODE	4H300D4820002	3P106C06400F1	277800195	277051532	3M903D0450004
	Qty	1	1	6	6	3
75	MODEL	-	-	1MBI600NP-060	2R160E-080	4E-230B
	CODE	4H300D4820002	3P106C06400G9	277800195	277051532	3M903D0450004
	Qty	1	1	6	6	3
100	MODEL	-	-	CM300HA-12H	2R1100E-080	S175-2-HWB
	CODE	4H300D4820002	3P106C06400H7	3H324D0460000	277051516	279152115
	Qty	1	1	12	6	3

Table 6 Spare Parts for 440V Class

INVERTER & PART NAME		Control PC Board*	Power Board	Main Circuit Transistor	Main Circuit Diode	Cooling Fan	
HP	SPEC						
25	MODEL	-	-	7MBP075RA120	DF75LA160	AFB0824SH-B	-
	CODE	4H300D4820002	3P106C06500C1	277831538	277192195	4H300D1050001	-
	Qty	1	1	1	1	2	-
30	MODEL	-	-	CM100DU-24F	DF75LA160	A2123-HBT	ASB0624H-B
	CODE	4H300D4820002	4P106C02900A2	277810280	277192195	4M903D1890001	4H300D1060007
	Qty	1	1	3	1	2	1
40	MODEL	-	-	CM150DU-24F	DF100LA160	A2123-HBT	ASB0624H-B
	CODE	4H300D4820002	4P106C02900A2	277810298	277192217	4M903D1890001	4H300D1060007
	Qty	1	1	3	1	2	1
50	MODEL	-	-	CM200DU-24F	2U/DDB6U145N16L	A2123-HBT	ASB0624H-B
	CODE	4H300D4820002	4P106C02900A2	277810301	277190222	4M903D1890001	4H300D1060007
	Qty	1	1	3	1	2	1
60	MODEL	-	-	CM200DU-24F	2U/DDB6U145N16L	AFB1224SHE	AFB0824SH-B
	CODE	4H300D4820002	4P106C02900A2	277810301	277190222	4M903D1880006	4H300D1440004
	Qty	1	1	3	1	2	1
75	MODEL	-	-	CM300DU-24F	2U/DDB6U205N16L	AFB1224SHE	AFB0824SH-B
	CODE	4H300D4820002	4P106C02900A2	277810310	277190249	4M903D1880006	4H300D1440004
	Qty	1	1	3	1	2	1
100	MODEL	-	-	SKM400GB128D	SKKH106/16E	FFB1224EHE	ASB0624H-B
	CODE	4H300D4820002	4P106C02900D7	277810611	277112302	4H300D5110009	4H300D1060007
	Qty	1	1	3	3	2	1
125	MODEL	-	-	CM600HU-24F	2RI100G-160	AFB1224SHE	A2123-HBT
	CODE	4H300D4820002	4P106C02700A1	277800225	277051524	4M903D1880006	4M903D1890001
	Qty	1	1	6	6	3	1
150	MODEL	-	-	CM600HU-24F	2RI100G-160	AFB1224SHE	A2123-HBT
	CODE	4H300D4820002	4P106C02700A1	277800225	277051524	4M903D1880006	4M903D1890001
	Qty	1	1	6	6	3	1
175	MODEL	-	-	CM600HU-24F	2RI100G-160	AFB1224SHE	A2123-HBT
	CODE	4H300D4820002	4P106C02700A1	277800225	277051524	4M903D1880006	4M903D1890001
	Qty	1	1	6	6	3	1
215	MODEL	-	-	CM400HU-24F	2RI100G-160	EFB1524HHG	A2123-HBT
	CODE	4H300D4820002	4P106C02700A1	277800217	277051524	4M300D3680002	4M903D1890001
	Qty	1	1	12	6	3	1
250	MODEL	-	-	CM400HU-24F	2RI100G-160	EFB1524HHG	A2123-HBT
	CODE	4H300D4820002	4P106C02700A1	277800217	277051524	4M300D3680002	4M903D1890001
	Qty	1	1	12	6	3	1
300	MODEL	-	-	Skiip1203GB122-2DL	SKKH500/E16	2RRE45250* 56R	-
	CODE	4H300D4820002	3P106C0060009	4M903D2030006	4M903D2000000	4M903D1940009	-
	Qty	1	1	3	3	2	-
400	MODEL	-	-	Skiip1513GB122-2DL	SKKH500/E16	2RRE45250* 56R	-
	CODE	4H300D4820002	3P106C0060009	4M903D2040001	4M903D2000000	4M903D1940009	-
	Qty	1	1	3	3	2	-



7. SPECIFICATIONS

- **Basic Specifications**

220V CLASS

INVERTER (HP)		25	30	40	50	60	75	100
MAX. APPLICABLE MOTOR OUTPUT HP (KW)*1		25 (18.5)	30 (22)	40 (30)	50 (37)	60 (45)	75 (55)	100 (75)
Output Characteristics	Inverter Capacity (KVA)	34	41	54	57	67	85	128
	Rated Output Current (A)	80	96	130	160	183	224	300
	Max. Output Frequency	3-Phase, 200/208/220/230V (Proportional to input voltage)						
	Rated Output Frequency	Up to 400Hz available						
Power Supply	Rated Input Voltage And Frequency	3-Phase, 200/208/220V, 50Hz 200/208/220/230V, 60Hz						
	Allowable Voltage Fluctuation	+10% ~ -15%						
	Allowable Frequency Fluctuation	±5%						

440V CLASS

INVERTER (HP)		25	30	40	50	60	75	100	125	150	175	215	250	300	400
MAX. APPLICABLE MOTOR OUTPUT HP (KW)*1		25 (18.5)	30 (22)	40 (30)	50 (37)	60 (45)	75 (55)	100 (75)	125 (90)	150 (110)	175 (132)	215 (160)	250 (185)	300 (220)	400 (300)
Output Characteristics	Inverter Capacity (KVA)	34	41	54	68	82	110	138	180	195	230	260	290	385	513
	Rated Output Current (A)	40	48	64	80	96	128	165	192	224	270	300	340	450	600
	Max. Output Frequency	3-Phase, 380/400/415/440/460V (Proportional to input voltage)													
	Rated Output Frequency	Up to 400Hz available													
Power Supply	Rated Input Voltage And Frequency	3-Phase, 380/400/415/440/460V, 50/60Hz													
	Allowable Voltage Fluctuation	+10% ~ -15%													
	Allowable Frequency Fluctuation	±5%													

* 1 Based on 4 pole motor

● CHARACTERISTICS

Control Characteristics	Control Method	<ul style="list-style-type: none"> ● Sine wave PWM ● Four control modes (switched by parameter) <ul style="list-style-type: none"> – V/F control – Sensorless vector control (With Auto-tuning) – PID&Auto Energy Saving control – V/F+PG control
	Starting Torque	<ul style="list-style-type: none"> ● V/F control: 150% at 3Hz ● Sensorless Vector control: 150% at 1Hz
	Speed Control Range	<ul style="list-style-type: none"> ● V/F control: 1 : 10 ● Sensorless Vector control: 1 : 60
	Speed Response	5Hz (Sensorless Vector)
	Speed Control Accuracy	<ul style="list-style-type: none"> ● V/F control: ±1% (with slip compensation) ● V/F + PG Control : ±0.03% ● Sensorless Vector control: ±0.5%
	Frequency Control Range	0.1 ~ 400.0Hz
	Frequency Setting Resolution	Digital reference: 0.01Hz (100Hz Below); Analog reference: 0.06Hz/60Hz
	Frequency Accuracy	Digital reference: ±0.01% (-10 ~ +40°C); Analog command: ±0.1% (25°C ± 10°C)
	Output Frequency Resolution	0.01Hz (1/30000)
	Frequency Setting Signal	0 ~ 10VDC (20KΩ), 4~20mA (250Ω)
	Overload Capacity	150% rated output current for 1 minute.
	Accel/Decel Time	0.1 ~ 6000.0 sec (Accel/Decel time settings independently)
	Efficiency at Rated Freq.	0.95 above
	Braking Torque	Approx. 20% (Approx. 125% When using braking resistor) Inverter of 220V 20HP (15KW) or less and 440V 25HP (18.5KW) or less have a Built-in braking transistor
Protective Functions	Motor Overload Protection	Electric thermal overload relay
	Instantaneous Overcurrent (OC) and Short Circuit Protection	Motor coasts to stop at approx. 200% rated output current.
	Inverter Overheat Protection (OL2)	150% inverter rated output current for 1 min.
	Overvoltage (OV)	Motor coasts to stop if the main circuit voltage exceeds 410VDC (820VDC for 440V class)
	Undervoltage (UV)	Motor coasts to stop if the main circuit voltage drops to 190VDC (380VDC for 440V class)
	Momentary Power Loss	Immediately stop after 15 ms or longer power loss (at factory setting) Continuous operation during power loss less than 2 sec. (standard)
	Fin Overheat (OH)	Thermostat
	Stall Prevention	Stall prevention during acceleration/deceleration and constant speed operation.
	Ground Fault (GF)	Provided by electronic circuit.
	Power Charge Indication	Indicates until main circuit voltage reaches 50V.
Environmental Conditions	Location	Indoor (Protected from corrosive gases and dust)
	Humidity	95% RH (non-condensing)
	Storage Temperature	-20 ~+60°C (for short period during shipping)
	Ambient Temperature	-10 to +40°C (for NEMA1 type); -10 to +45°C (for open chassis type)
	Altitude	1000m or below
	Vibration	9.8m/s ² at 20Hz or below, up to 2m/s ² at 20 to 50Hz
Communication Function	MODBUS, PROFIBUS (option)	



(b) 220V : 25HP~100HP

440V : 30HP~250HP

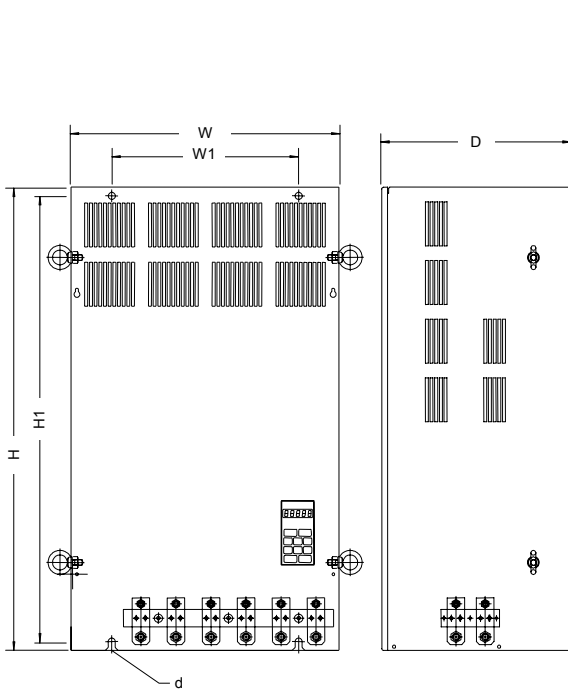

(Open Chassis Type – IP00)

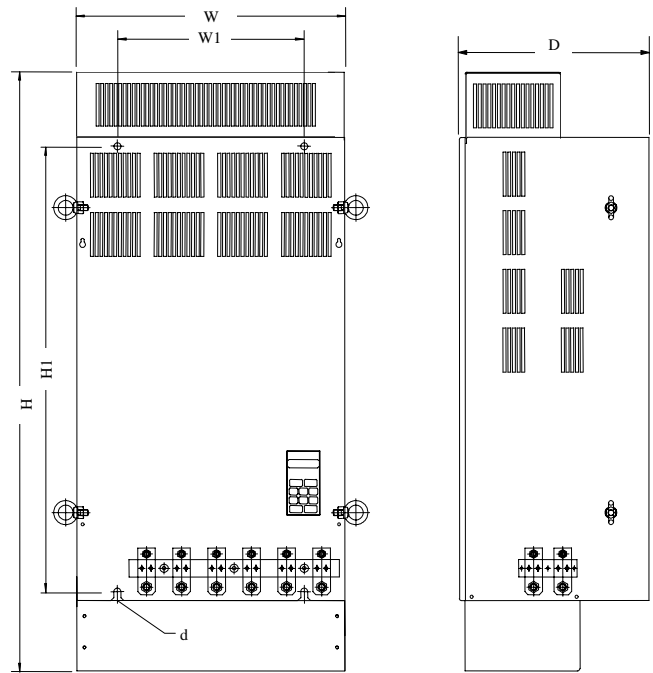

(Wall-mounted Type – NEMA1)



(d) 440V : 300HP, 400HP

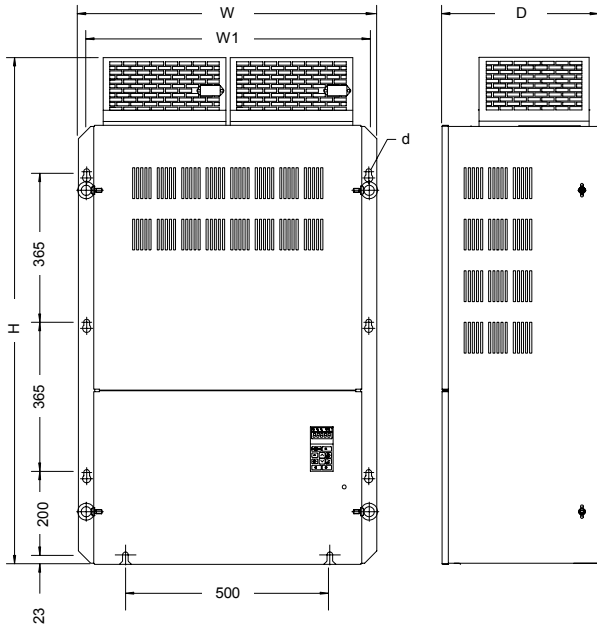

(Open Chassis Type — IP00)

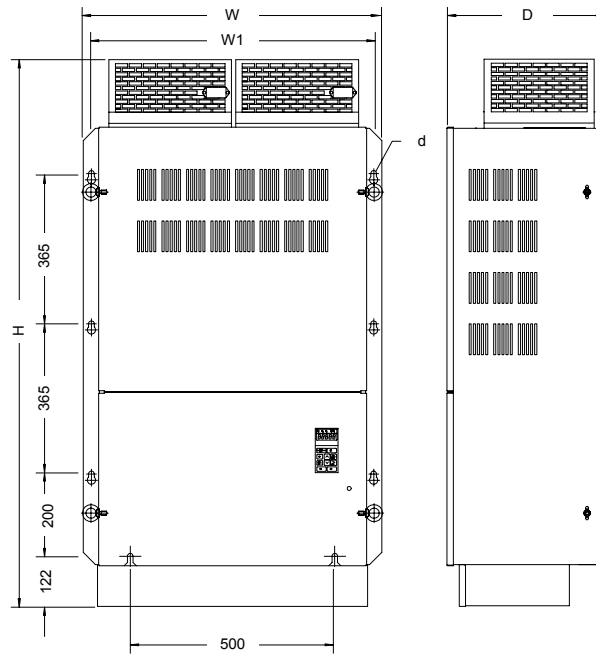

(Wall-mounted Type — NEMA1)

9. PERIPHERAL AND OPTIONS

9.1 AC REACTOR

- When power capacity is significantly large compared to inverter capacity, or when the power factor needs to be improved, externally connect an AC reactor.
- 7200GS 220V 25 ~ 100HP and 440V 30 ~ 250HP have built-in DC reactor as standard. (When the power factor needs to be improved, externally connect an AC reactor).
- 440V 25HP connects an optional AC reactor When the power factor needs to be improved.
- 440V 300 ~ 400HP need to connect an AC reactor externally.

Table 8 AC REACTOR

Inverter			AC Reactor		
Voltage	HP	Rated current (A)	Current (A)	Inductance (mH)	Code NO.
220V	25	80	90	0.12	3M200D1610102
	30	96	120	0.09	3M200D1610111
	40	130	160	0.07	3M200D1610269
	50	160	200	0.05	3M200D1610277
	60	183	240	0.044	3M200D1610285
	75	224	280	0.038	3M200D1610293
	100	300	360	0.026	3M200D1610307
440V	25	40	50	0.42	3M200D1610218
	30	48	60	0.36	3M200D1610226
	40	64	80	0.26	3M200D1610234
	50	80	90	0.24	3M200D1610242
	60	96	120	0.18	3M200D1610251
	75	128	150	0.15	3M200D1610315
	100	169	200	0.11	3M200D1610323
	125	192	200	0.11	3M200D1610323
	150	224	250	0.09	3M200D1610331
	175	270	330	0.06	3M200D1610340
	215	300	330	0.06	4M200D0010340
	250	340	400	0.05	4M200D0010008
	300	450	500	0.04	4M200D0020003
400	600	670	0.032	4M200D0040004	

9.2 NOISE FILTER

9.2.1 INPUT NOISE FILTER

- When input noise filter is installed as indicated, the 7200GS will comply with the EN55011A noise interference suppression directive.

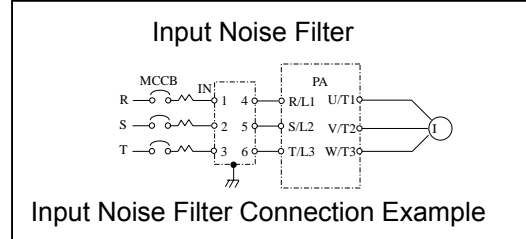

Table 9 Input Noise Filter

Inverter			Input Noise Filter		
Voltage (V)	HP	Rated current (A)	Code NO.	Model NO.	Rated current (A)
220V	25	80A	4H000D1690004	FS6100-90-34	90A
	30	96A	4H000D1710005	FS6100-150-40	150A
	40	130A	4H000D1710005	FS6100-150-40	150A
	50	160A	4H000D1720001	FS6100-250-99	250A
	60	183A	4H000D1720001	FS6100-250-99	250A
	75	224A	4H000D1750007	FS6100-400-99	400A
	100	300A	4H000D1750007	FS6100-400-99	400A
440V	25	40A	4H000D1770008	FS6101-50-52	50A
	30	48A	4H000D1790009	FS6101-80-52	80A
	40	64A	4H000D1790009	FS6101-80-52	80A
	50	80A	4H000D1800004	FS6101-120-35	120A
	60	96A	4H000D1800004	FS6101-120-35	120A
	75	128A	4H000D1820005	FS6101-200-40	200A
	100	165A	4H000D1820005	FS6101-200-40	200A
	125	192A	4H000D1850001	FS6101-320-99	320A
	150	224A	4H000D1850001	FS6101-320-99	320A
	175	270A	4H000D1850001	FS6101-320-99	320A
	215	300A	4H000D1880008	FS6101-400-99	400A
	250	340A	4H000D1880008	FS6101-400-99	400A

	300	450A	4H000D1900009	FS6101-600-99	600A
	400	600A	4H000D1910004	FS6101-800-99	800A

Note: All the line wire of U/T1, V/T2, W/T3 phase must pass through the same zero-phase core in the same winding sense.

9.3 BRAKING RESISTOR AND BRAKING UNIT

- The braking transistor of 440V 25HP was built-in as standard, the braking resistor can be connected to main circuit terminals B2 and ⊕ directly. The others without built-in braking transistor need to connect braking unit with braking resistor externally.
- When connecting braking resistor or braking unit with braking resistor, set system parameter Sn-10=XX1X (i.e. stall prevention during deceleration not enabled).
- Braking resistor and braking unit selection table is shown below.

Table 10 Braking Resistor and Braking Unit

Inverter			Braking Unit		Braking Resistor			Braking Torque (%)
Voltage	HP	Rated current (A)	Type	Number used	Code NO.	Specs.	Number used	
220V	25	80A	JUVPLV-0060	1	3H333C0020108	4800W/6.8Ω	1	125%(10%ED)
	30	96A	JUVPLV-0040	2	3H333C0020086	3000W/10Ω	2	125%(10%ED)
	40	130A	JUVPLV-0040	2	3H333C0020086	3000W/10Ω	2	100%(10%ED)
	50	160A	JUVPLV-0060	2	3H333C0020108	4800W/6.8Ω	2	120%(10%ED)
	60	183A	JUVPLV-0060	2	3H333C0020108	4800W/6.8Ω	2	100%(10%ED)
	75	224A	JUVPLV-0060	3	3H333C0020108	4800W/6.8Ω	3	110%(10%ED)
	100	300A	JUVPLV-0060	3	3H333C0020108	4800W/6.8Ω	3	90%(10%ED)
440V	25	40A	—	—	3H333C0190005	1600W/50Ω	1	70%(5%ED)
	30	48A	JUVPHV-0040	1	3H333C0020213	6000W/20Ω	1	125%(10%ED)
	40	64A	JUVPHV-0060	1	3H333C0020221	9600W/16Ω	1	125%(10%ED)
	50	80A	JUVPHV-0060	1	3H333C0020230	9600W/13.6Ω	1	125%(10%ED)
	60	96A	JUVPHV-0040	2	3H333C0020213	6000W/20Ω	2	135%(10%ED)
	75	128A	JUVPHV-0060	2	3H333C0020230	9600W/13.6Ω	2	145%(10%ED)
	100	165A	JUVPHV-0040	3	3H333C0020213	6000W/20Ω	3	120%(10%ED)
	125	192A	JUVPHV-0040	3	3H333C0020213	6000W/20Ω	3	100%(10%ED)
	150	224A	JUVPHV-0040	4	3H333C0020230	6000W/20Ω	4	115%(10%ED)
	175	270A	JUVPHV-0060	4	3H333C0020230	9600W/13.6Ω	4	140%(10%ED)
	215	300A	JUVPHV-0060	4	3H333C0020230	9600W/13.6Ω	4	120%(10%ED)
	250	340A	JUVPHV-0060	4	3H333C0020230	9600W/13.6Ω	4	100%(10%ED)
	300	450A	JUVPHV-0060	5	3H333C0020230	9600W/13.6Ω	5	110%(10%ED)
400	600A	JUVPHV-0060	5	3H333C0020230	9600W/13.6Ω	5	100%(10%ED)	

9.4 OTHERS

9.4.1 DIGITAL OPERATOR WITH EXTENSION WIRE

- Used for the operation of LCD (or LED) digital operator or monitor when removed from the front of inverter unit.

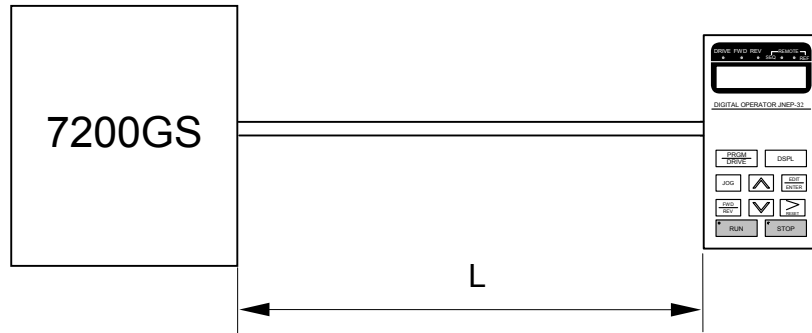

Cable Length	Extension Cable Set*1	Extension Cable Set*2	Blank Cover*3
1m	4H332D0010000	4H314C0010003	4H300D1120000
2m	4H332D0030001	4H314C0030004	
3m	4H332D0020005	4H314C0020009	
5m	4H332D0040006	4H314C0040000	
10m	4H332D0130005	4H314C0060001	

*1 : Including special cable for LCD (or LED) operator, blank cover, fixed use screws and installation manual.

*2 : One special cable for digital operator.

*3 : A blank cover to protect against external dusts, metallic powder, etc.

- The physical dimension of LCD (or LED) digital operator is drawn below.

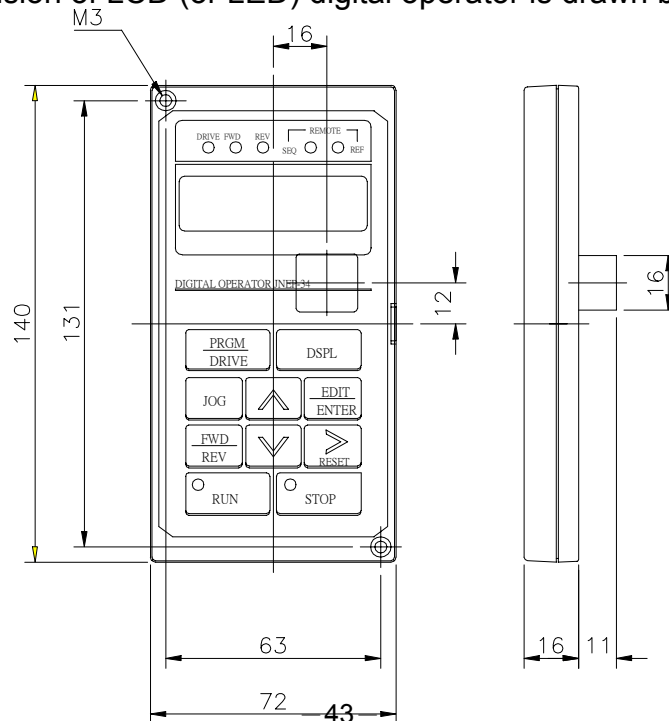

Fig. 6 LCD Digital Operator Dimension

9.4.2 ANALOG OPERATOR

All 7200GS have the LCD (or LED) digital operator. Moreover, an analog operator as JNEP-16 (shown in fig. 7) is also available and can be connected through wire as a portable operator. The wiring diagram is shown below.

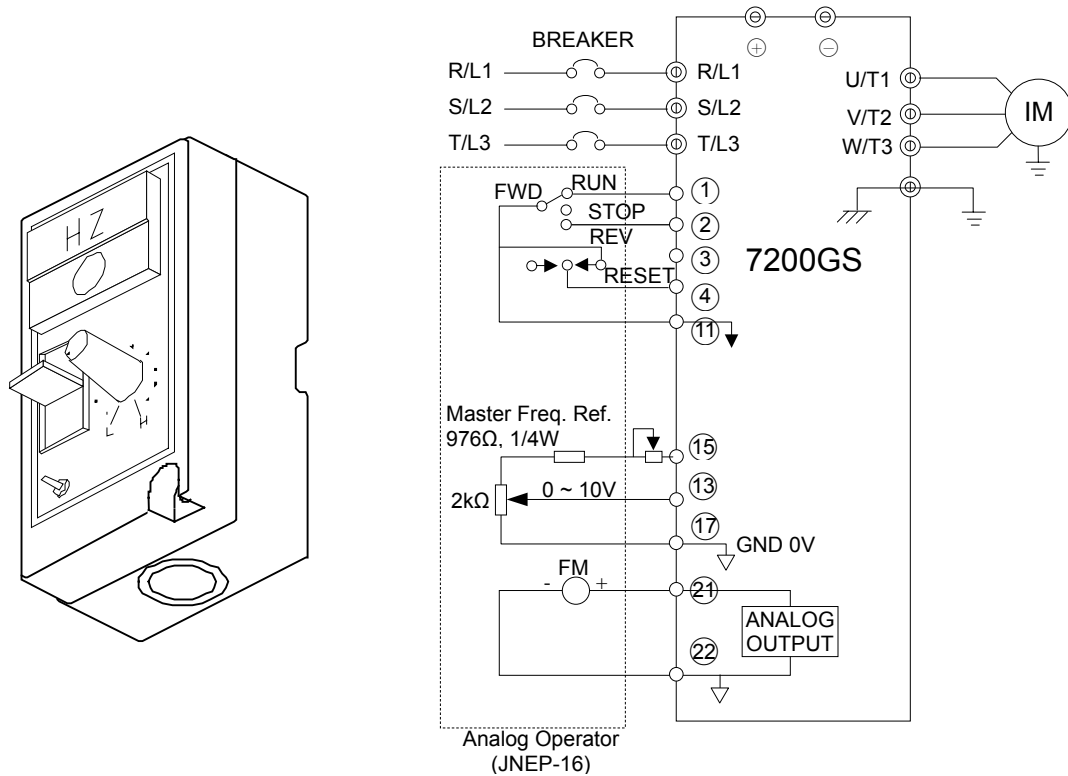

Fig. 7 Analog Operator

9.4.3 LED DIGITAL OPERATOR

- All 7200GS have standard with LCD digital operator (JNEP-34). Moreover, an LED digital operator JNEP-33 (shown in Fig. 10) is also available and can be connected through the same cable and connector.
- The LED digital operator has the same installation and dimension with the LCD digital operator.



9.4.4 OPTION CARDS

○: Valid
 ✕: Invalid

Name	Code No.	Descriptions	Valid Access Levels				Install Location
			GP	SL	PID	PG	
RS-485 Communication Card SI-M	4H300D4560001	MODBUS RTU protocol communication optional card: ● Communication method: Asynchronous ● Communication speed: 19.2Kbps (max.) ● Interface: RS-232, RS-422, RS-485	○	○	✕	✕	2CN
PG Speed Controller Card FB-C	3H300D1180009	} Permits compensation of speed variation caused by slip, by speed feedback using a pulse generator (PG) provided to the motor: ● Phase A (signal pulse) input. ● PG frequency range: 50 to 65535Hz ● Pulse monitor output: +12V, 20mA ● Input Voltage: +12V External supply ● Input current: 300mA	✕	✕	✕	○	3CN
Digital pulse monitor Card PM-C	3H331C0060008	Outputs pulse train signal corresponding to the inverter output frequency ● Output pulse: 1F, 6F, 10F, 12F, 36F (F: output frequency) ● Output voltage: +12V ±10% (isolated) ● Output current: 20mA max	○	✕	○	✕	3CN
Analog monitor Card AO-12	4H300D3850005	Output analog signal for monitoring inverter output state (output frequency, output current etc.) ● Output resolution: 11 bits (1/2048) ● Output voltage: -10 to +10V (non isolated) ● Output channel: 2 channels	○	○	○	✕	3CN
Digital reference Card DI-08	4H300D4570006	Allows 8 bits digital speed reference set. ● Input signal: binary 8 bits/BCD 2 digits + code ● Input voltage: +24V (isolated) ● Input current: 8mA	○	○	○	○	2CN
Analog reference Card AI-14B	4H300D4580001	Allows bipolar high precision, high resolution analog speed reference set. ● Input signal level: 0 to ±10VDC (20KΩ) 4 to 20mA (250Ω)	○	○	○	○	2CN

		3 channels					
		● Input resolution: 13 bits + code (1/8192)					

Name	Code No.	Descriptions	Valid Access Levels				Install Location
			GP	SL	PID	PG	
V/I Conversion card V/I card	3P103D0280001	Converts the multi-function analog output (terminals ⑳-㉓) signal from 0~10V to 4~20mA signal	○	○	○	○	3CN
Digital output card DO-08		Outputs isolated type digital signal for monitoring inverter run state (alarm signal, zero speed detection etc.) <ul style="list-style-type: none"> ● Output channel: Photo coupler 6 channels (48V, 50mA or less) Relay contact output 2 channels 250VAC, 1A or less 30VDC, 1A or less 	○	○	○	×	3CN
MODBUS Communication card GS-M		MODBUS RTU protocol communication optional card. <ul style="list-style-type: none"> ● Communication method: Asynchronous ● Communication speed: 19.2Kbps (max.) ● Interface: RS-485, RS-422 	○	○	○	○	1CN
PROFIBUS Communication card GS-P		PROFIBUS protocol communication optional card: <ul style="list-style-type: none"> ● Communication method: Asynchronous ● Communication speed: depend ● Interface: RS-485 	○	○	○	○	1CN

【Installation】 Use the following procedure to install these option card.

- 1>. Turn off the main circuit power supply.
- 2>. Leave it off for a least one minute before removing the front cover of the inverter. Check to be sure that the CHARGE indicator is OFF.
- 3>. Insert the spacer (Which is provided with the option card) into the spacer hole at the control board.
- 4>. Pass the spacer through the spacer hole at the option card. Check to be sure that it is precisely aligned with the 2CN or 3CN position, and snap it into the proper position.

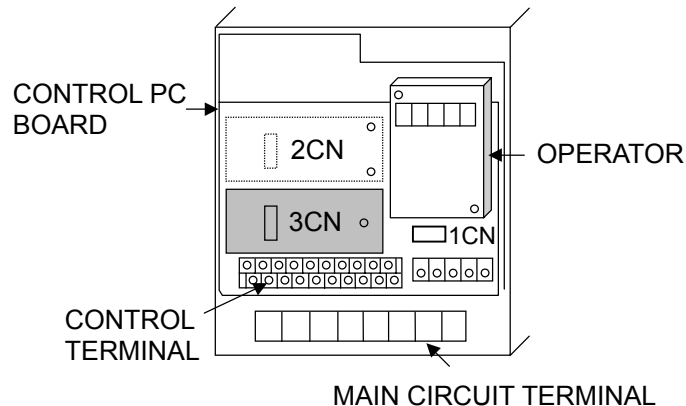

Fig. 8 Option card Installation

